



Marine Type Container
Refrigeration & Heating Unit

海上コンテナ冷凍装置

Model

LXE 10E-A

DAIKIN INDUSTRIES, LTD.

TR01-07

ORDERING INSTRUCTIONS

The parts list contains the parts of the DAIKIN Marine Type Container Refrigeration Units. Please read the following items before using the list.

1. When ordering the parts, be sure to specify the model No., the name of part and the type of part. When ordering the parts for which no parts NO. is shown in the PARTS NO. column, be sure to describe DWG.NO..
2. The list shows the parts only for replacement or repairing at the job site. Certain parts require a production lead time or are supplied as a set, so please contact with the nearest DAIKIN PARTS CENTRE.

3. Index symbols;

Meaning of the ranking A,B and C are as follows;

A. The most important spare parts

1. The parts whose malfunction cause fatal damage to the unit.
2. The parts with high risk of malfunction.
3. The parts that are worn out after an extended service period.

B. The important spare parts next to A, but the risk of malfunction is not so high.

C. The parts with low risk of malfunction, but recommendable to stock to cope with damage during handling of container box and long delivery time, etc.

The parts without A, B and C mark is the parts whose necessity is not so high under normal operation.

パーツリスト使用上の注意

このパーツリストはダイキン海上コンテナ冷凍装置の部品を集録してあります。パーツリスト使用にあたっては、必ず次の注意事項をご一読の上使用していただくようお願いいたします。

1. 部品のご注文の際は機種名、部品番号、および部品名、形式を必ずご指定ください。
なお、部品番号欄が空白になっている部品は、図面番号で指示願います。
2. 掲載部品の範囲は、あくまでも現地にて分解修理できるところまで記載しております。
一部部品につき納期のかかるものおよびセット単位となるものもありますので、お近くのダイキンパーツセンター又はサービスステーションに相談願います。

3. INDEXの説明

INDEXのA、B、Cの意味は下記の通りです。

A. 最も重要な部品

1. 故障した場合に最も重大な損害を与えると思われる部品
2. 故障の確率が高いと思われる部品
3. 長期の使用で摩耗して使用できなくなる部品

B. 故障発生の確率は高くはないが、Aについて重要な部品

C. 故障発生の確率は低いですが、コンテナボックスの運搬中の事故や、部品の納期が長期になるとと思われる等の理由で、在庫をお勧めする部品

A,B,Cマークの無い部品は、通常の運転では必要性は高くない部品です。

Denomination of Model Name

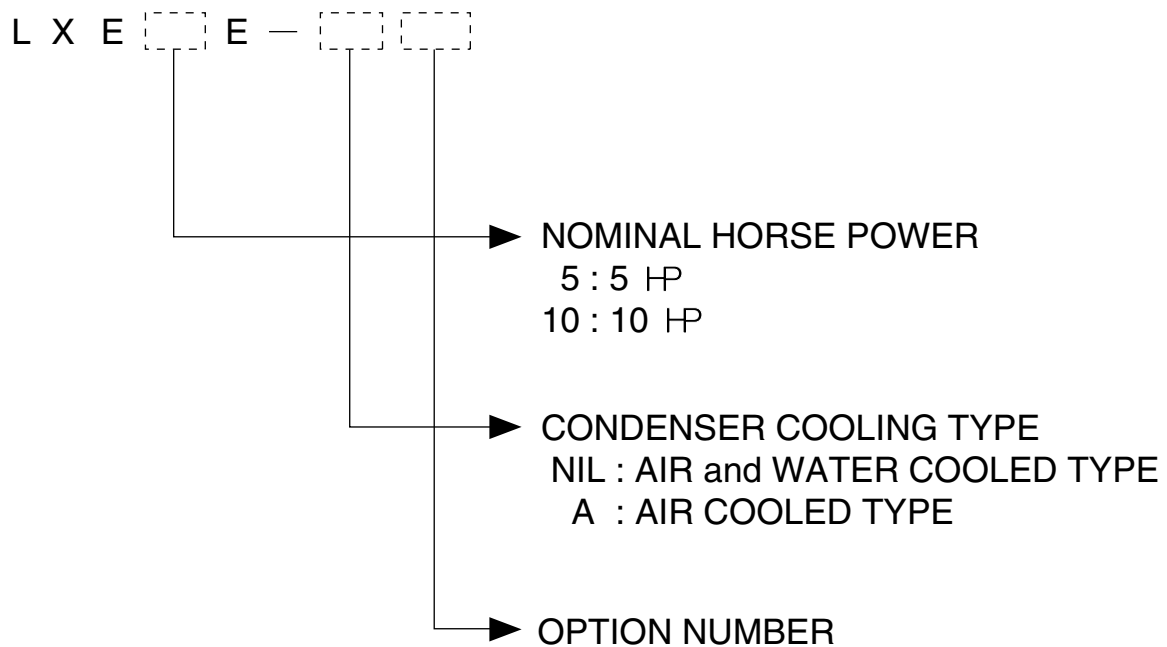

Note) "R" GIVEN AFTER OPTION NUMBER STANDS FOR "REVISION" AND IT IS GIVEN FOR THE UNIT WHICH IS SPECIALLY MODIFIED.

機種名について

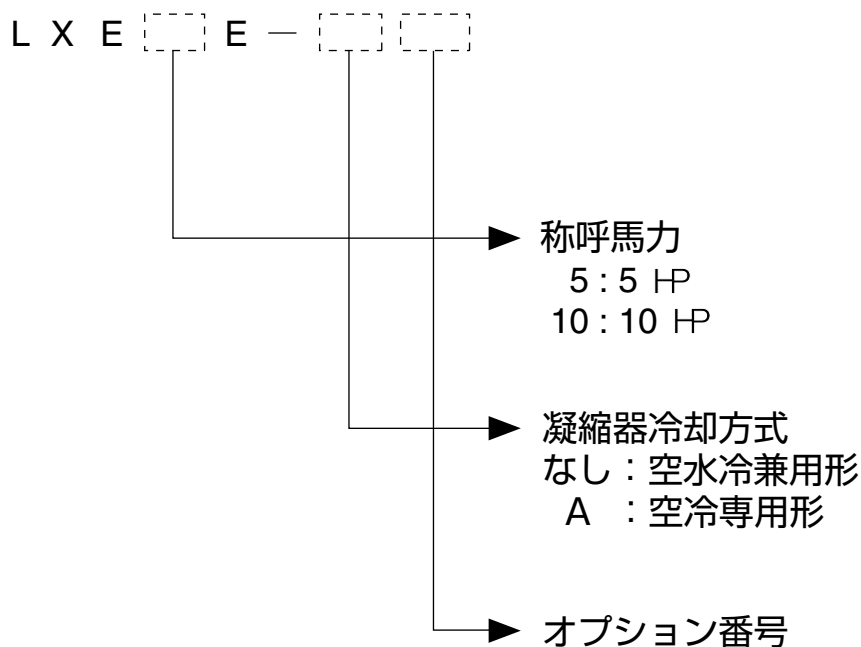

注) オプション番号の後に R がつく機種は、改造機で、特別な仕様が加えられていることを意味します。

A. Parts related with the unit(outside)	4
庫外関連部品	
B. Parts related with refrigerant piping(outside)	6
庫外冷媒配管関連部品	
C. Parts related with the unit(inside)	10
庫内関連部品	
D. Parts related with refrigerant piping(inside)	12
庫内冷媒配管関連部品	
E. Other parts(Pipe clamp, sealing and insulation material etc.)	14
その他部品 (配管固定具、シール材、防熱材等)	
F. Control box	22
コントローラボックス	
G. Parts related with name plate	26
銘板関連	
H. Parts related with option 1 – Recorder box	28
オプション関連部品 1 - レコーダボックス	
I. Parts related with option 2 – USDA	32
オプション関連部品 2 - USDA関連	
J. Parts related with option 3 – MODEM	33
オプション関連部品 3 - モデム	
K. Parts related with option 4 – Others	34
オプション関連部品 4 - その他	
1. Indoor fan guard 庫内ファンガード	
2. Evaporator coil 蒸発器コイル組立品	
L. List of size for standard pipe clamp	36
配管固定具サイズ表	
1. Resin clamp 樹脂バンド	
2. Tube clamp 管止金	
3. Cushion rubber for pipe clamp 管止金用緩衝ゴム	
M. Note for ordering spare parts	38
部品発注の際の注意事項	
1. Parts recommended to be ordered together with packing, gasket, sealing material and name plate 発注の際にパッキングやシール材、銘板等の同時発注を推奨する部品	
2. Order for motorized valve, solenoid valve and pressure regulating valve 電動弁・電磁弁・圧力調整弁の発注	
3. Order for pressure transducer 圧力センサーの発注	
4. Order for temperature sensor 温度センサーの発注	
N. Measuring and adjusting tools	43
測定調整用工具	
1. Tools for emergency operation 緊急運転用工具	
2. Personal computer cable (for DCCS) パソコンケーブル(DCCS用)	

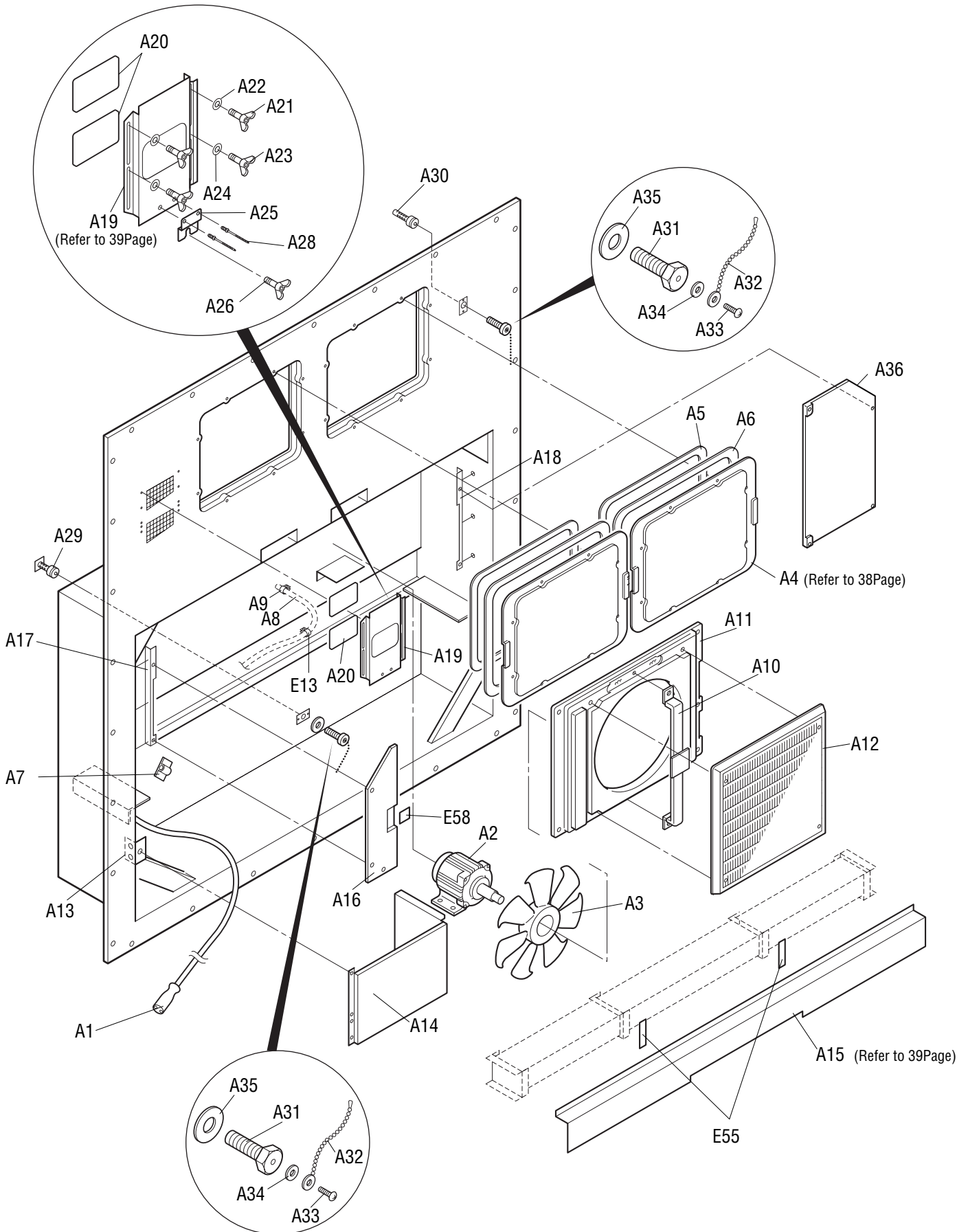

NO. 符号	INDEX	PARTS NO. 部品番号	PARTS NAME	部品名称	DWG. NO. 図面番号	TYPE SPECIFICATION 形式 仕様	QTY/UNIT 1台当たりの 所要数	REMARKS 備考
A1		1266113	Power plug(400V calss)	電源プラグ (400V)	3P055393-1		1	
A2	A	0954936	Condenser fan motor	凝縮器電動機	3P005566-1		1	
A3	B	0980618	Fan Brade(outside)	プロペラファン(庫外側)	2P004956-1	P44H11S	1	
A4	C	0980423	Acesses panel ass'y	サービス扉組立品	1P006678-1		2	Refer to Page38
A5		1266207	Cushion material(access panel)	クッション材 (サービス扉)	3P033608-1		2	Refer to Page38
A6		1196113	Sealing material (access panel)	シール材 (サービス扉)	3P001640-2		2	Refer to Page38
A7		1266269	Wire clamp	電線止め金	4P049488-1		1	
A8	C	1266199	Drain hose	ドレンホース	3P011299-1	For trap type	1	
A9		537320	Hose band	ホースバンド	R4716528-3		1	
A10		1266137	Fan guide stay ass'y(outside)	ファンガイドステー組立品(庫外側)	3P027891-1		1	
A11		1198652	Fan guide(outside)	ファンガイド (庫外側)	1P050906-1	IVORY WHITE	1	
A12	C	0983167	Discharge grille	吹出しグリル	1PA53427-1		1	
A13		1266144	Mounting plate, front plate(cable)	取付板	4P006981-1		1	
A14		1266151	Front plate (cable)	前板 (鋁金) (ケーブル)	2P010527-2		1	
A15	C	1270338	Front plate(CA)	前板 (CA)	2P061345-1		1	Refer to Page39
A16		1266175	Control, box front plate(left,single)	C, BOX前板 (左)	3P074787-1		1	
A17		1238428	Fixing plate(left)	外板取付板 (2)	3P047546-1		1	
A18		1266182	Fixing plate(right)	外板取付板 (2)	3P047544-1		1	
A19	B	1266120	Ventilation cover	換気口蓋	3P067053-1		1	Refer to Page39
A20		1266221	Sealing material (access panel)	シール材(換気口)	4P016185-1		2	Refer to Page39
A21		1270345	Wing bolt	蝶ボルト	4P048681-1		2	
A22		1270352	M6 wood washer	M6木材座金	4P066385-6		2	
A23		1270345	Wing bolt	蝶ボルト	4P048681-1		2	
A24		1270352	M6 wood washer	M6木材座金	4P066385-6		2	
A25		1266214	Holding plate, ventilator	押エ板	4P067052-1		1	
A26		1270345	Wing bolt	蝶ボルト	4P048681-1		1	
A28		1177509	Stainless rivet	ステンレスリベット	4P057425-1		2	
A29		1266252	Protection cover for thermometer	温度計挿入口保護カバー	4P066104-1		1	
A30		306645	Protection cover for thermometer	温度計挿入口保護カバー	4PA19070-1		1	
A31		1266238	Hexagon head bolt	PC六角ボルト	R4290921-125	M12X25	2	
A32		9900353	Chain	ビクターチェーン	R4717233-1		2	
A33		1266245	Tapping screw	タッピンネジ	4SK05064-8	M3 SUS304	2	
A34		844012S	Plain washer	平座金	4SK07005-3	M3SUS	2	
A35		1267084	Gasket, resin bolt	パッキン樹脂ボルト用	4PA63573-1		2	
A36		1270369	Front plate, holding plate(right)	押エ板前板(右)	3P083136-1		1	
E13		1266788	Resin clamp	樹脂バンド	NE41015-12	MILK WHITE	7	
E55		1267077	Packing for prevention of vibration	CA前板ビビリ防止パッキン	4P050050-1		2	
E58		1267109	Packing for control box cover	パッキン (C, BOX蓋)	4P070346-1		1	

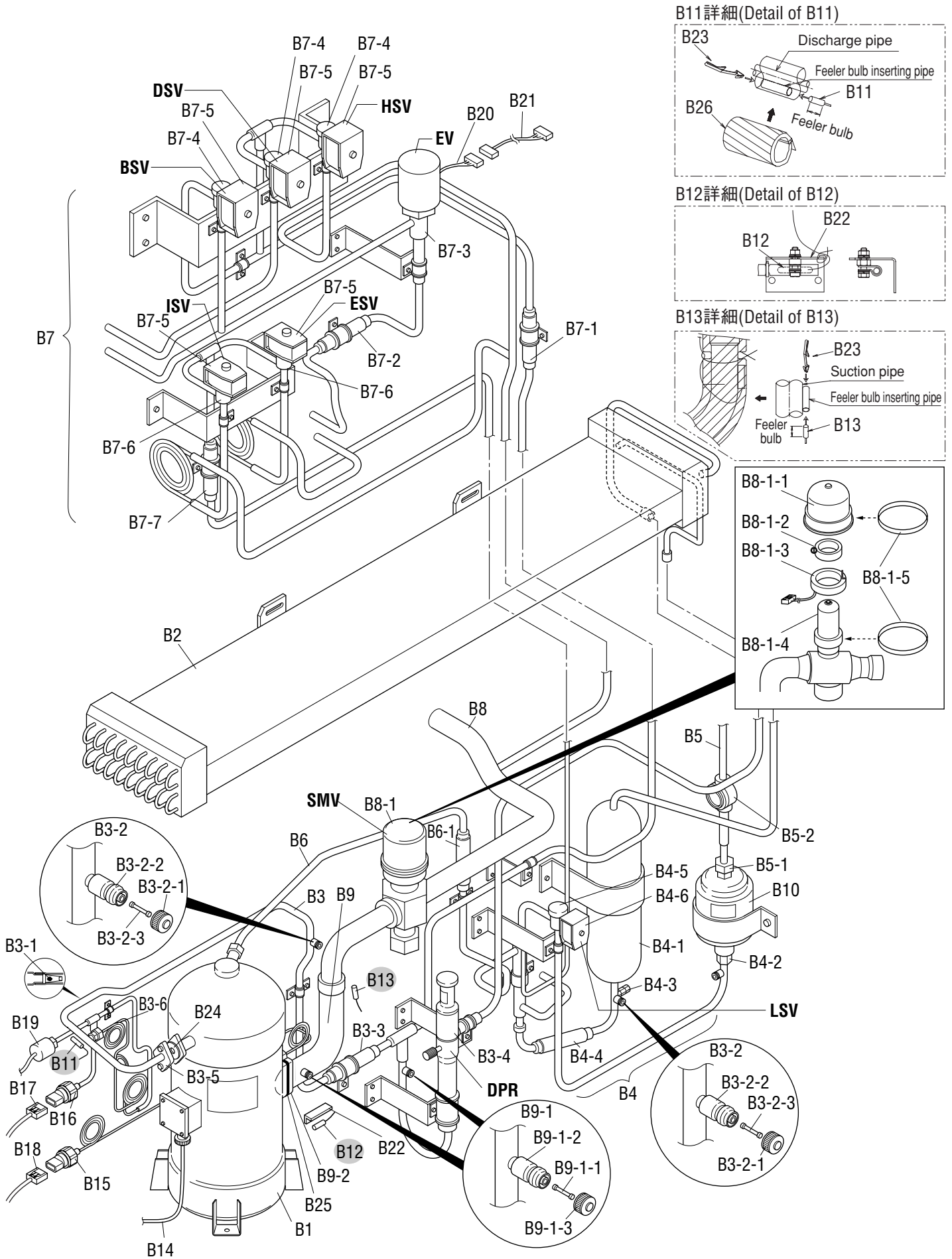

NO. 符号	INDEX	PARTS NO. 部品番号	PARTS NAME	部品名称	DWG. NO. 図面番号	TYPE SPECIFICATION 形式 仕様	QTY/UNIT 1台当たりの 所要数	REMARKS 備考
B1	A	1199415	Compressor	圧縮機	JT224D-NYR		1	
B2	C	1225965	Air cooled condenser	空冷凝縮器	2P059337-1	CA-LXE10E	1	
B3			Discharge pipe ass'y	吐出配管ASSY	2P079943-1		1	
B3-1		1199167	Strainer	ストレーナ	4P051389-1		1	
B3-2	C	1178920	Service valve ass'y	サービスバルブ組立品	3P048905-1		2	
B3-2-1	B	1175921	Service valve cap	キャップ	3P048905-1-KU		2	
B3-2-2	B		Service valve body	本体	3P048905-1-KA		2	
B3-2-3	B	1178850	Valve core	バルブコア	3P048905-1-KI		2	
B3-3	B	0684220	Check valve	逆止弁	3SA27008-1		1	
B3-4	A	1241361	Discharge pressure regulating valve	吐出圧力調整弁	3P074558-1		1	DPR Refer to Page40
B3-5		1266276	Flange(convex)	吐出管フランジ (凸)	4P065933-1		1	
B3-6	B	292011	Gauge joint(with check valve)	逆止弁付ゲージ接手	2PF00177-1	VCG2DA	1	
B4			Liquid receiver ass'y	受液器Assy	2P081418-1		1	
B4-1		1266283	Liquid receiver	受液器レシーバ	4P081428-1	φ90×t1.5	1	
B4-2		0137856	Flare nut	フレアナット	4SK23011-4	FNS4 φ12.7	1	
B4-3	A	292216	Fusible valve	可溶栓	NI31023-2		1	
B4-4		0299134	Filter	フィルタ	3SA26004-2		1	
B4-5	A	0944566	Nev type solenoid valve body	NEV型電磁弁本体	R3305118-1	NEV-803DXF	1	
B4-6	A	0955287	Coil, nev type solenoid valve	NEV型電磁弁コイル	3P010453-1		1	
B5			Liquid pipe ass'y	液配管 ASSY	3P065985-1		1	
B5-1		0137856	Flare nut	フレアナット	4SK23011-4	FNS4 φ12.7	1	
B5-2	A	0622107	Liquid moisture indicator	モイスタイマーインジケーター	3PA51270-3	SGN12S	1	
B6			Injection tube ass'y	インジェクション管組立品	3P081248-1		1	
B6-1		0299134	Filter	フィルタ	3SA26004-2		1	
B7			Expansion pipe ass'y	膨張弁配管組立品	1P079353-1		1	
B7-1		0975522	Filter	フィルタ	3P011071-1		1	
B7-2		0299134	Filter	フィルタ	3SA26004-2		1	
B7-3	A	1256495	Electronic expansion valve body ass'y	電子膨張弁本体組立品	2SA50010-2-KU		1	EV Refer to Page40
B7-4	A	0944566	NEV type solenoid valve body	NEV型電磁弁本体	R3305118-1	NEV-803DXF	3	HSV, DSV ,BSV Refer to Page40
B7-5	A	0955287	Solenoid valve coil	電磁弁コイル	3P010453-1		5	HSV, DSV ,BSV, ESV, ISV Refer to Page40
B7-6	A	0088738	Nev type solenoid valve body	NEV型電磁弁本体	R3305099-1-KI	NEV-202DXF	2	ISV, ESV Refer to Page40
B7-7		0299127	Filter	フィルタ	3SA26004-1		1	
B8			Suction pipe ass'y	吸入配管ASSY	3P071569-1		1	
B8-1	A	1254538	Suction modulating valve ass'y	吸入比例弁ASSY	2P078385-1		1	SMV Refer to Page40
B8-1-1		1270376	Upper cover, suction modulating valve	吸入比例弁カバー上	2P078385-1-KA		1	
B8-1-2		1270383	Clamp, suction modulating valve	吸入比例弁クランプ	2P078385-1-KI		1	
B8-1-3		1270390	Coil, suction modulating valve	吸入比例弁コイル	2P078385-1-KU		1	
B8-1-4		1270408	Body, suction modulating valve	吸入比例弁本体	2P078385-1-KE		1	
B8-1-5		1270415	Cover band, suction modulating valve	吸入比例弁カバーバンド	2P078385-1-KO		2	
B9			Suction piping ass'y(1)	吸入配管ASSY (1)	2P079186-1		1	

• When ordering the parts whose No. are not shown in the PARTS NO. column, be sure to describe DWG. NO..

• 部品番号欄が空白になっている部品は、図面番号で、指示願います。

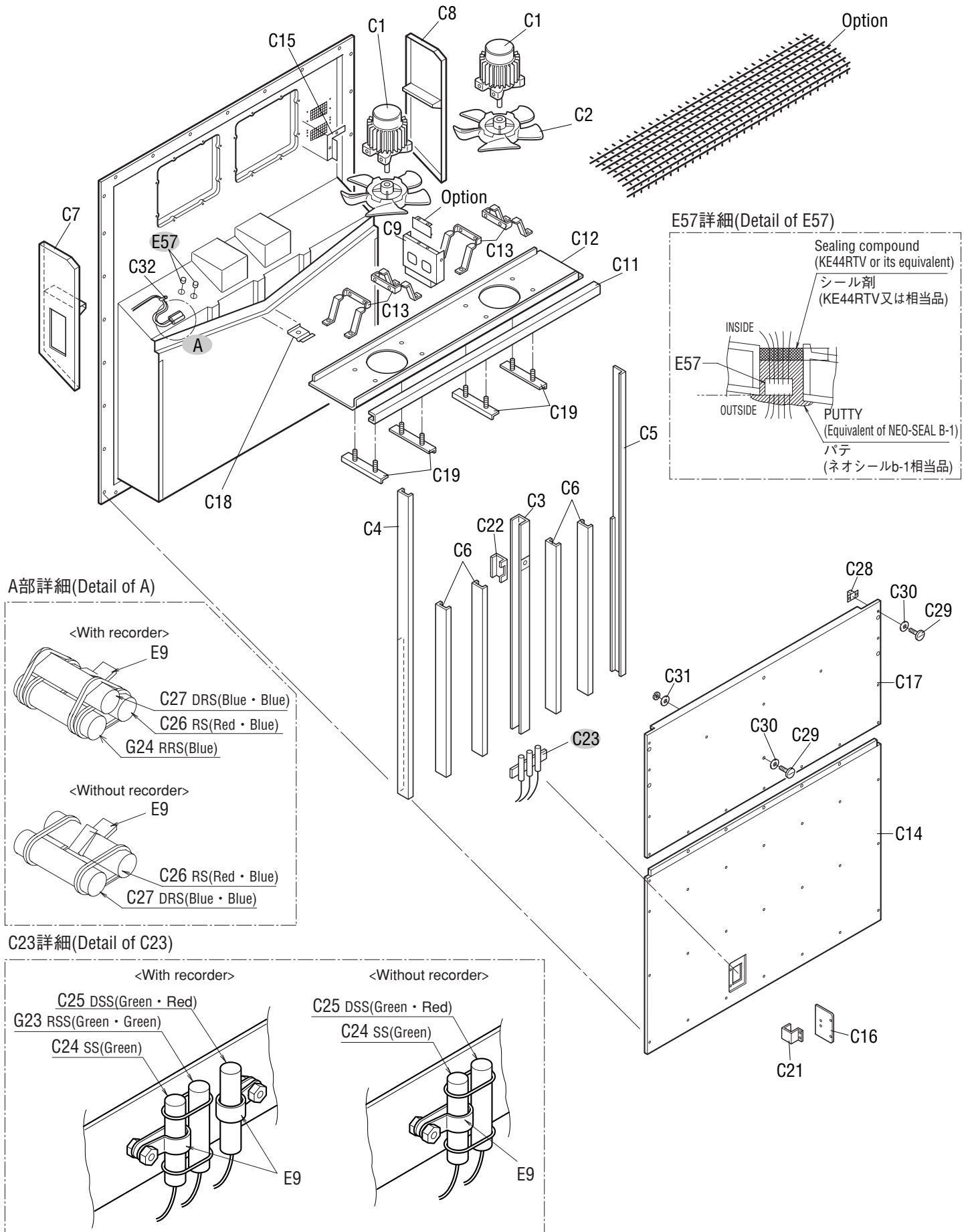

NO. 符号	INDEX	PARTS NO. 部品番号	PARTS NAME	部品名称	DWG. NO. 図面番号	TYPE SPECIFICATION 形式 仕様	QTY/UNIT 1台当たりの 所要数	REMARKS 備考
C1	A	0807333	Three phase AC fan motor	三相交流ファン電動機	3PA07524-3	SPRK91A-42	2	Cable length 2520
C2	B	0777519	Fan Brade(inside)	プロペラファン(庫内側)	P32P11F		2	
C3		1266353	Center stay	中央ステー	3P061344-1	t2.5	1	
C4		1266360	Side stay	サイドステー	3P061281-1	t2.5	1	
C5		1266377	Side stay(2)	サイドステー (2)	3P061282-1	t2.5	1	
C6		1266384	Rear stay	背面ステー	3P061343-1	t2.0	4	
C7		1266391	Casing frame,evaporator(left)	蒸発器枠 (1)	2P071765-1		1	
C8		1266409	Casing frame,evaporator(right)	蒸発器枠 (2)	2P071765-2		1	
C9		1266416	Fixing plate, fan guide	ファンガイド固定板	3P061340-1		1	
C11		1266430	Support plate, fan guide	ファンガイド補強板	2P071560-1		1	
C12		1266447	Fan guide ass'y	ファンガイドASSY	3P071559-1		1	
C13		0673112	Set plate, fan motor	電動機取付脚	3PA51122-1		4	
C14		1270422	Rear plate(lower)	裏板 (下)	2P079641-1		1	
C15		1266555	Air reflection plate	風向板	4P055257-1		1	
C16		1266461	Inspection door	点検蓋	4P068969-1	t2.0	1	
C17		1266478	Rear plate(upper)	裏板 (上) 標準	2P080871-1		1	
C18		1266485	Partition plate (drain outlet)	仕切板 (ドレン出口)	4P011317-1		1	
C19		1135978	Reinforce plate, fan motor	補強板 (ファン電動機台)	4P011316-1		4	
C21		1135125	Hinge	蝶番	3P043374-1		1	
C22		1266524	Support plate	支柱補強柱	4P061342-1		1	
C23		1266517	Mounting plate, sensor	センサー取付板	3P069038-1		1	
C24	A	0798299	Sensor(SS)	センサー(SS)	3PA61769-3	ST9503-3(green)	1	Refer to Page42
C25	A	0798770	Sensor(DSS)	センサー(DSS)	3PA61769-8	ST9503-8(green, red)	1	Refer to Page42
C26	A	0798275	Sensor(RS)	センサー(RS)	3PA61769-1	ST9503-1(blue)	1	Refer to Page42
C27	A	0798732	Sensor(DRS)	センサー(DRS)	3PA61769-7	ST9503-7(blue,red)	1	Refer to Page42
C28		860015	Universal nut	自在ナット	R4713188-1		18	
C29		1266562	Speed bolt	スピードボルト (M6)	4P048680-2	M6X29(S)	18	
C30		860005	Washer, speed bolt	スピードボルト用座金	R4713334		19	
C31		840002	Drop out prevention washer	脱落防止座金	R4718607-6		1	
C32		388339	Fixture	固定具	4PA11782-1		3	
E9		0118273	Resin clamp	樹脂バンド	NE41015-2	Milk white	3	
E57		1267091	Wiring protection bush	配線保護ブッシュ	4P023920-1	BLACK	2	
G23	A	0798307	Sensor(RSS)	センサー(RSS)	3PA61769-4	ST9503-4(green,green)	1	オプション(optional) Refer to Page42
G24	A	0798282	Sensor(RRS)	センサー(RRS)	3PA61769-2	ST9503-2(blue)	1	オプション(optional) Refer to Page42

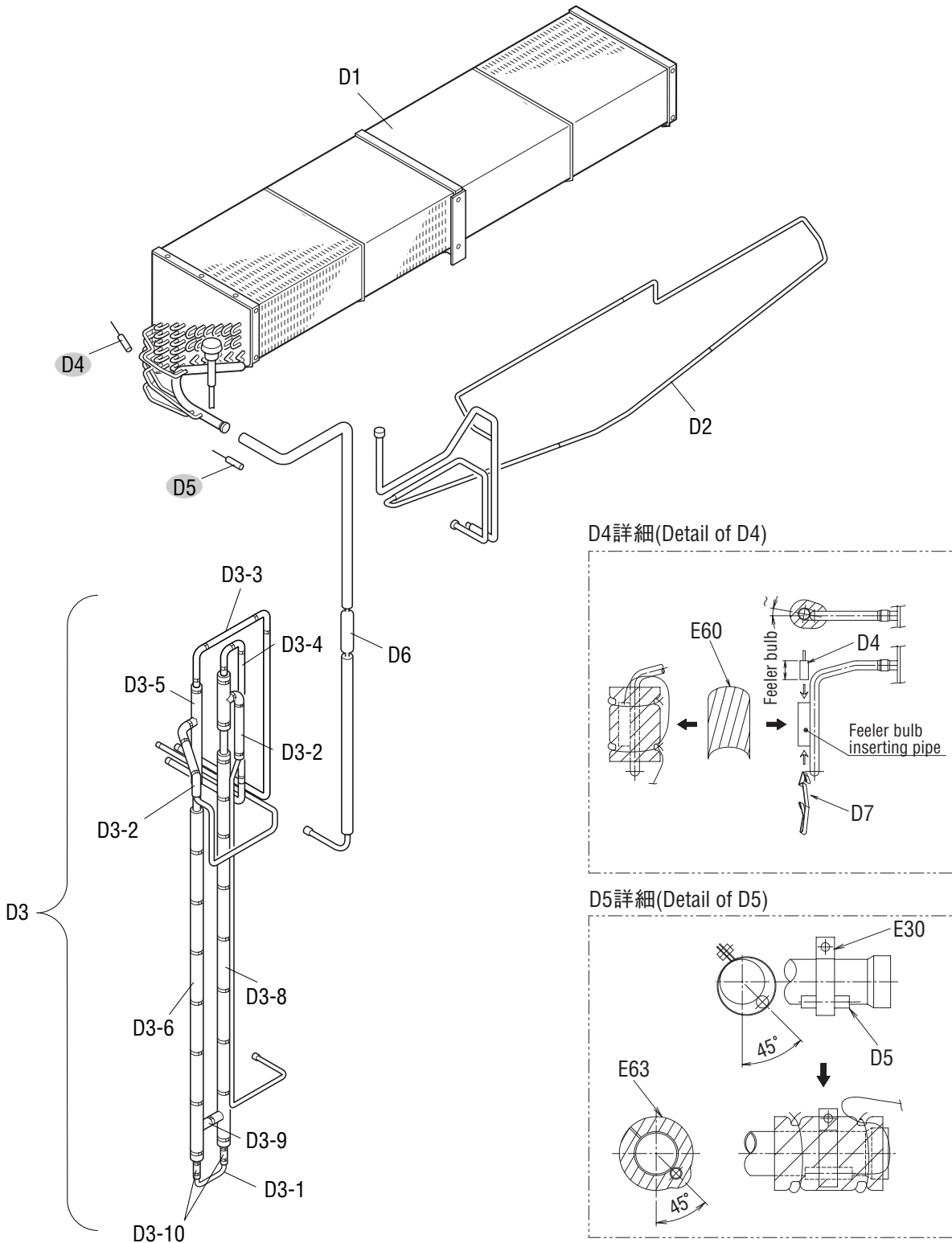

Other parts(Pipe clamp, sealing and insulation material etc.)
 その他部品 (配管固定具、シール材、防熱材等)

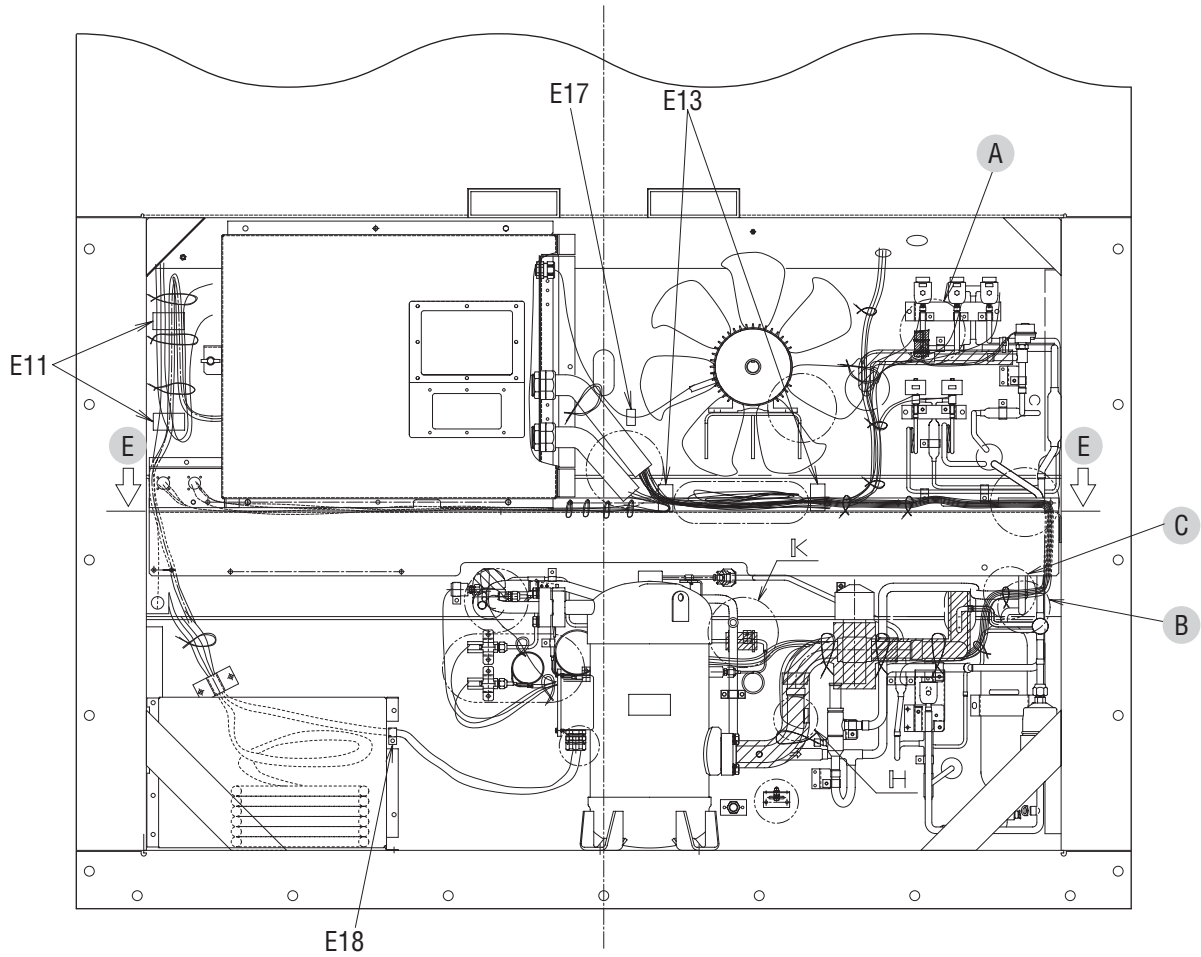

A詳細(Detail of A)

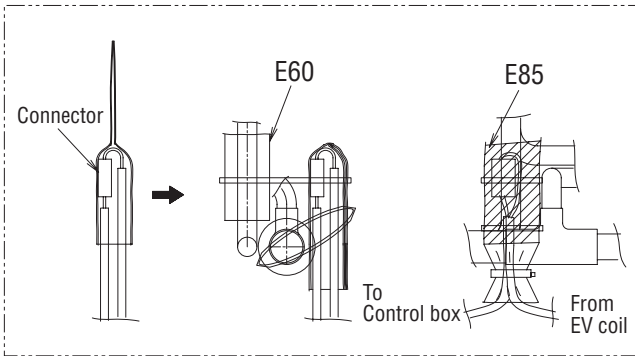

B詳細(Detail of B)

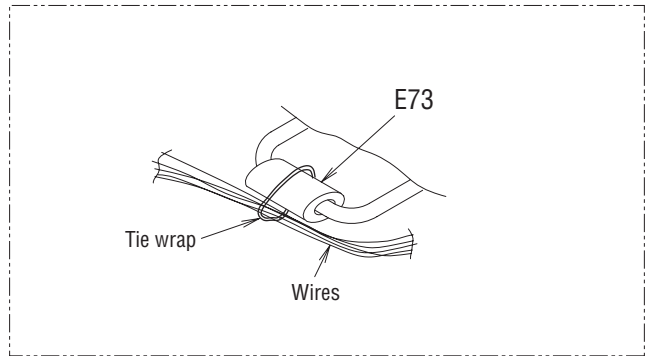

C詳細(Detail of C)

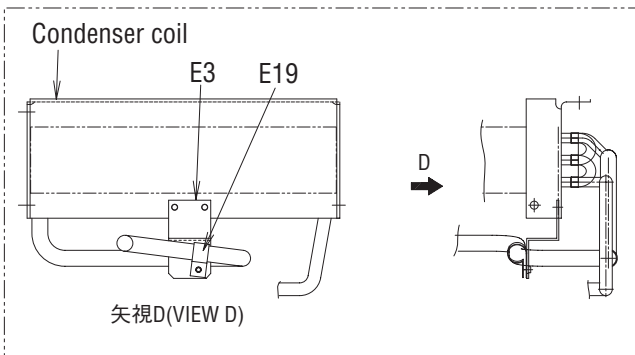

E断面(Section of E)

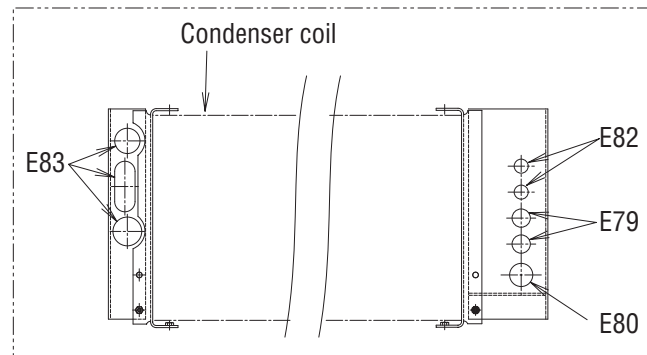

※(L = XX mm) indicates the length of cushion rubber E35. (Cut to suit pipe size.)

※(L = XX mm)と表記のものは、緩衝ゴム(E35)の長さです。(配管のサイズに合わせて切って使用ください。)

矢視A/B (View A/B)

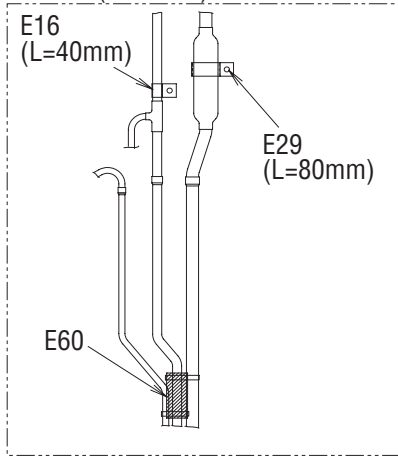

矢視C (View C)

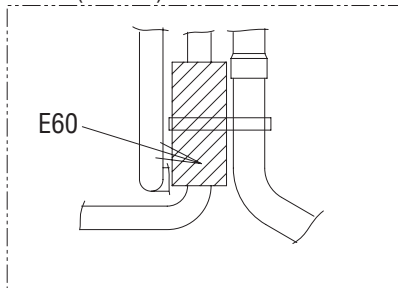

矢視D (View D)

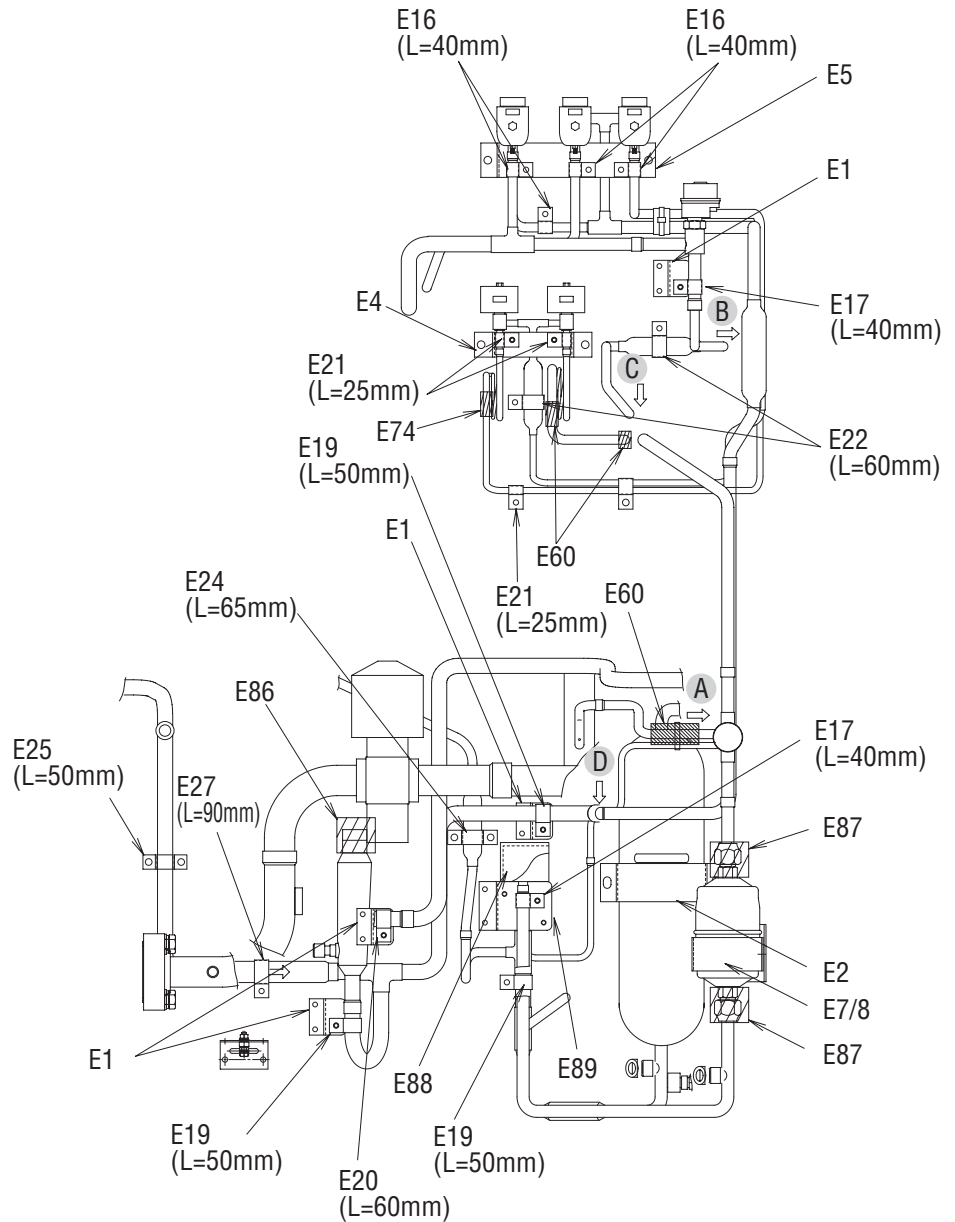
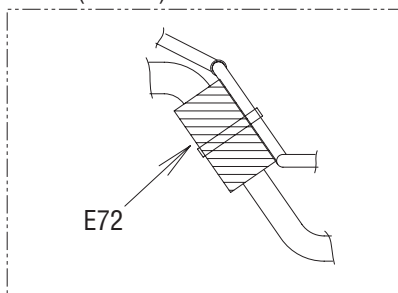

受液機器部詳細
(Receive part detail)

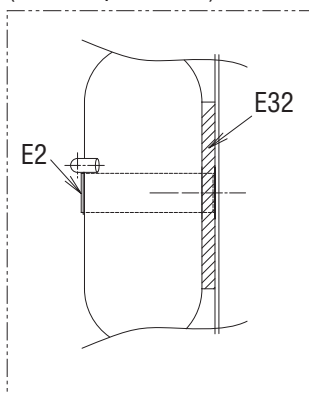

ドライヤー部詳細
(Dryer part detail)

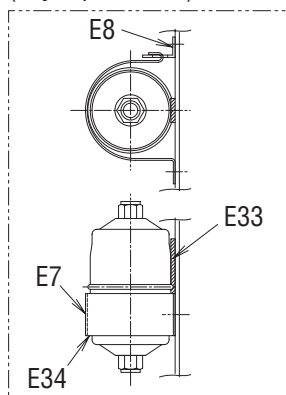

圧力センサー配管部詳細
(Pressure transducer detail)

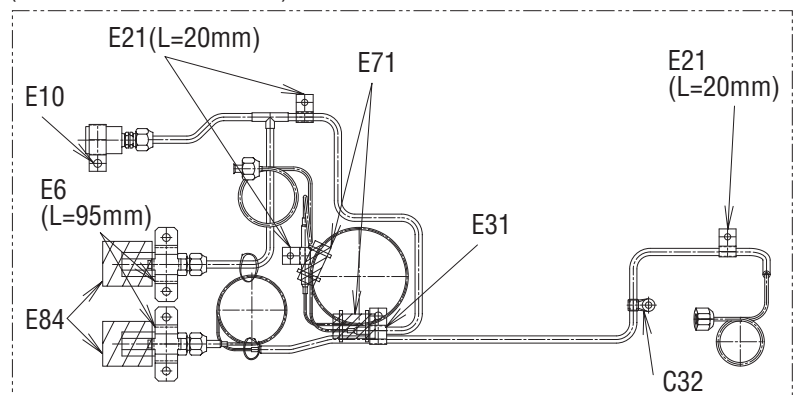

Other parts(Pipe clamp, sealing and insulation material etc.)
 その他部品 (配管固定具、シール材、防熱材等)

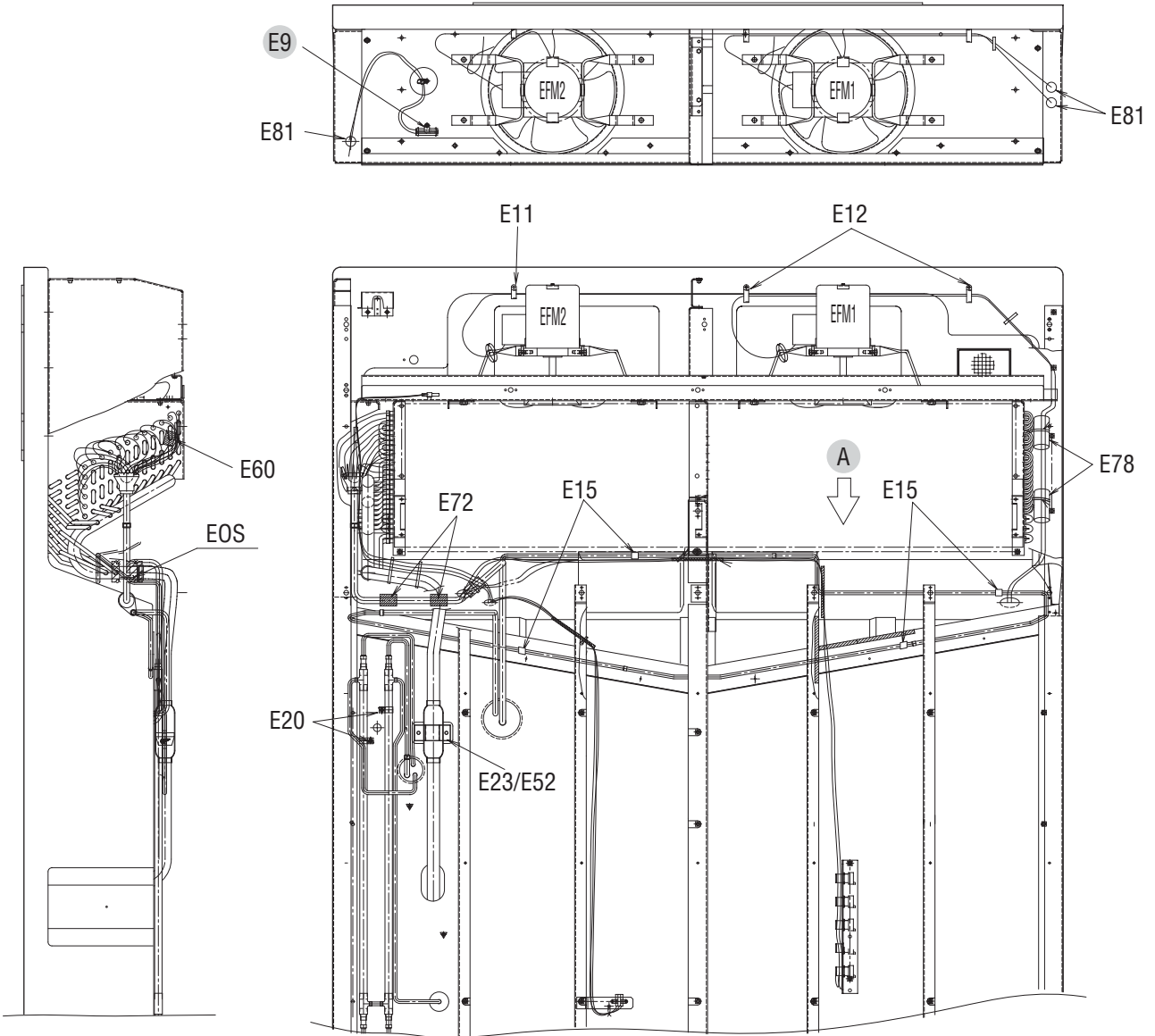

矢視A(VIEW A)

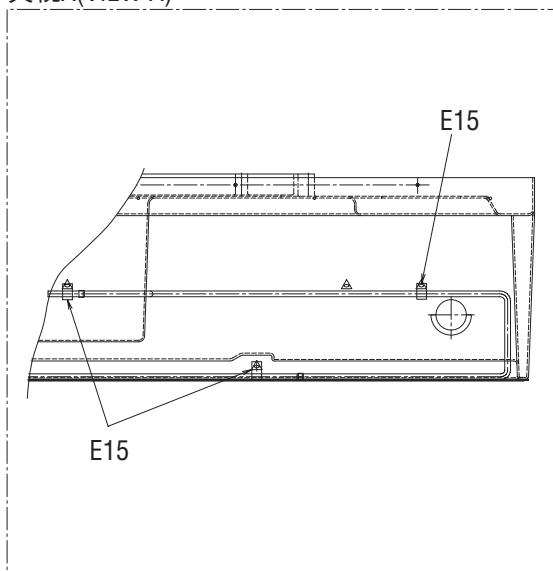

E9詳細(Detail of E9)

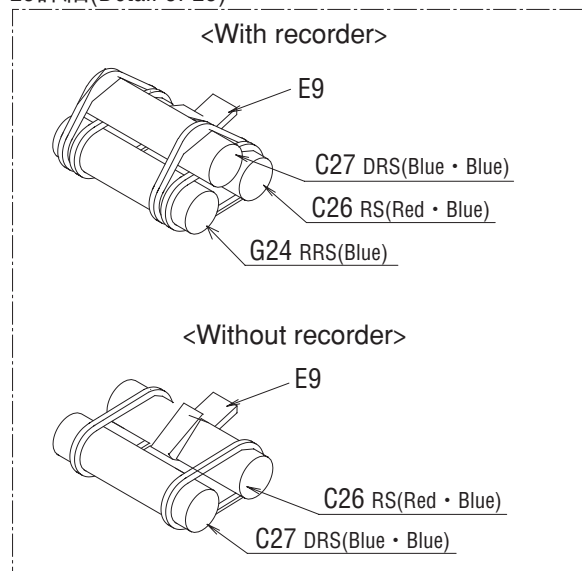

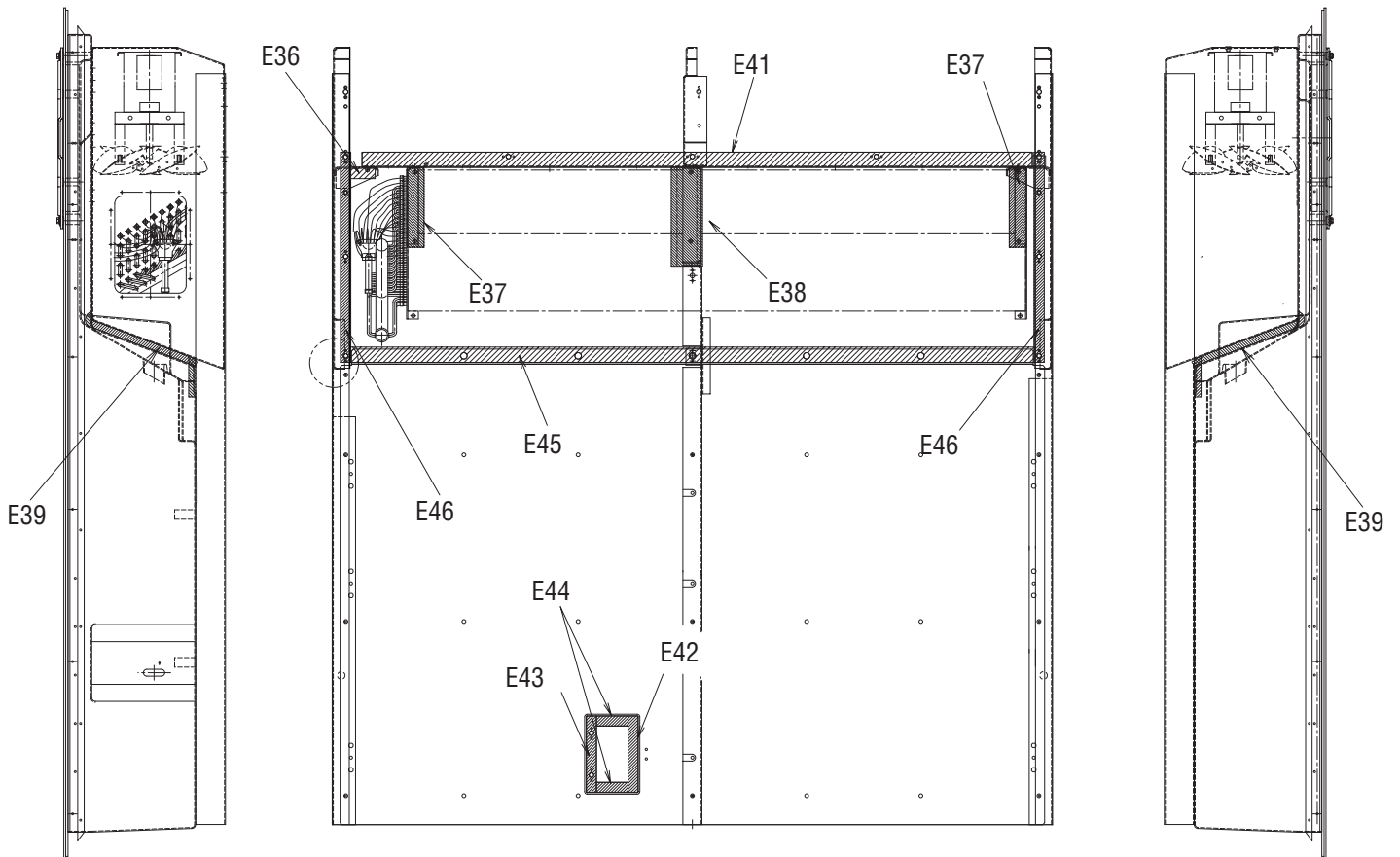
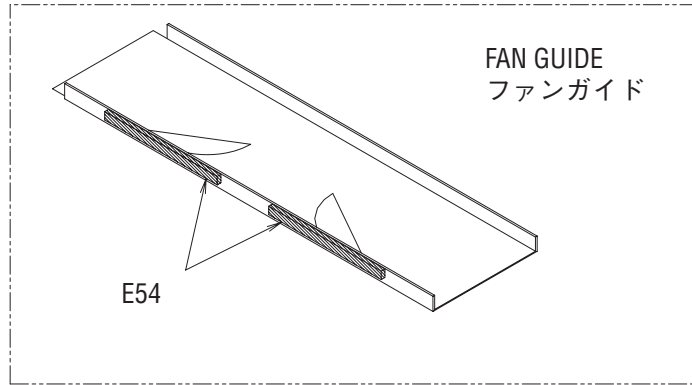

Other parts(Pipe clamp, sealing and insulation material etc.)
その他部品 (配管固定具、シール材、防熱材等)

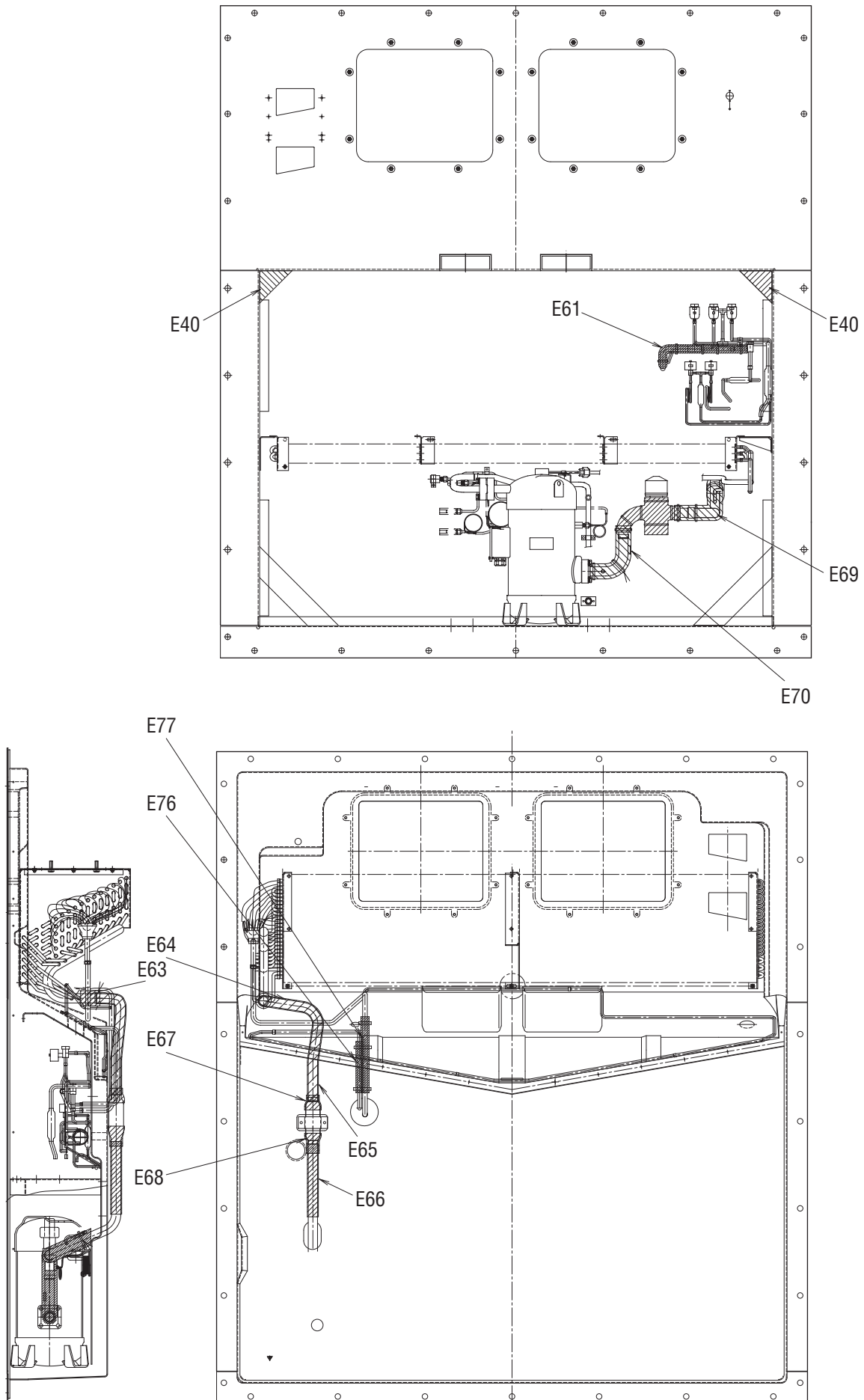

NO. 符号	INDEX	PARTS NO. 部品番号	PARTS NAME	部品名称	DWG. NO. 図面番号	TYPE SPECIFICATION 形式 仕様	QTY/UNIT 1台当たりの 所要数	REFER PAGE 参照ページ
E1		1266694	Set plate, discharge pipe	吐出配管取付板	4P079462-1		4	Page15
E2		1266702	Fixture plate, receiver	レシーバー固定具	4P011318-2	t1.5	1	Page15
E3		1266719	Set plate, CA inlet pipe	取付板 (液配管電磁弁) CA入口管	4P078250-1	t2.0	1	Page14
E4		1266726	Set plate, INJ solenoid valve	取付板 (INJ電磁弁取付板)	4P079329-1	t2.0	1	Page15
E5		1266733	Set plate, hot gas pipe	取付板 (ホットガス配管取付板)	4P079464-1	t2.0	1	Page15
E6		1270439	Tube clamp	管止金	NE31016-61		2	Page15
E7		1266764	Fitting band, dryer	ドライヤー取付バンド	4PA51194-1		1	Page15
E8		1266771	Set plate, dryer	取付板 (ドライヤ)	4P076788-1	t2.0	1	Page15
E9		0118273	Resin clamp	樹脂バンド	NE41015-2	MILK WHITE	4	Page16
E10		1222764	Resin clamp	樹脂バンド	NE41015-9	MILK WHITE	1	Page15
E11		0944528	Resin clamp	樹脂バンド	NE41015-7	MILK WHITE	4	Page14,16
E12		0142492	Resin clamp	樹脂バンド	NE41015-10	MILK WHITE	3	Page16
E13		1266788	Resin clamp	樹脂バンド	NE41015-12	MILK WHITE	7	Page14
E15		0782775	Tube clamp	管止め金	NE31016-51		5	Page16
E16		0702382	Tube clamp	管止め金	NE31016-52		5	Page15
E17		0414421	Tube clamp	管止め金	NE31016-53		2	Page14,15
E18		0700090	Tube clamp	管止め金	NE31016-54		1	Page14
E19		1266795	Tube clamp	管止め金	NE31016-55		3	Page14,15
E20		0016290	Tube clamp	管止め金	NE31016-56		3	Page15,16
E21		1266803	Tube clamp	管止め金	NE31016-70		9	Page15
E22		1266810	Tube clamp	管止め金	NE31016-57		2	Page15
E23		1266827	Fixing plate, filter	フィルター固定具	4P071794-1	t1.5	1	Page16
E24		1266834	Fixing plate, injection pipe	配管取付板 (インジェクション管)	4P063463-1		1	Page15
E25		1266841	Tube clamp	管止め金 (2)	4P005817-2		1	Page15
E27		1266858	Tube clamp	管止め金	NE31016-59		1	Page15
E29		1266865	Tube clamp	管止め金	NE31016-60		1	Page15
E30		537320	Hose band	ホースバンド	R4716528-3		1	Page12
E31		1266872	Hot gas tube clamp	ホットガス管止め金	4PA43040-3		1	Page15
E32		1266889	Cushion rubber, pipe clamp	緩衝ゴム (管止用)	4P064896-1	t1.0	1	Page15
E33		1266896	Seal packing	シールパッキン	4P011314-1		1	Page15
E34		1270446	Dryer cushion rubber	ドライヤ緩衝ゴム	4PA53083-2		1	Page15
E35		1266911	Cushion rubber	緩衝ゴム	NE41013-3-500	L=500	2	Page15
E36		1266928	Sealing packing	シールパッキン	4P008978-1		1	Page17
E37		1266935	Packing(for evaporator)	パッキン (蒸発器)	4P063465-1		2	Page17
E38		1266942	Packing(for evaporator)	パッキン (蒸発器)	4P063465-2		1	Page17
E39		1266959	Packing	パッキン	3P063471-1		2	Page17
E40		1177369	Cushion rubber	仕切用ゴム	4P026657-1	t2.0	2	Page18
E41		1266966	Sealing packing	シールパッキン	3P010707-1		1	Page17
E42		1266973	Sealing material(patch plate2)	シール材 (当板2)	4P068964-1	t5.0	1	Page17
E43		1266980	Sealing material(patch plate3)	シール材 (当板3)	4P068967-1	t5.0	1	Page17

Other parts(Pipe clamp, sealing and insulation material etc.)

その他部品 (配管固定具、シール材、防熱材等)

NO. 符号	INDEX	PARTS NO. 部品番号	PARTS NAME 部品名称	DWG. NO. 図面番号	TYPE SPECIFICATION 形式 仕様	QTY/UNIT 1台当たりの 所要数	REFER PAGE 参照ページ	
E44		1266997	Sealing material(patch plate1)	シール材 (当板1)	4P068968-1	t5.0	2	Page17
E45		1267008	Sealing packing	シールパッキン	3P011293-1		1	Page17
E46		1267015	Packing (side stay)	パッキン (サイドステー)	4P074127-1	BLACK	2	Page17
E52		1267053	Cushion rubber	緩衝ゴム	NE41013-4-140	L=140	1	Page16
E54		1267060	Packing for prevention of air bypass	バイパス防止用パッキン	4P011733-1		2	Page17
E55		1267077	Packing for prevention of vibration	CA前板ビビリ防止パッキン	4P050050-1		2	Page4
E57		1267091	Wiring protection bush	配線保護ブッシュ	4P023920-1	BLACK	2	Page10
E58		1267109	Packing for control box cover	パッキン (C. BOX蓋)	4P070346-1		1	Page4
E60		1267123	Thermal insulation tube piping	断熱筒配管緩衝材	4P011309-1		5	Page14,15,16
E61		1267130	EV outlet pipe insulation tube	膨張弁出口配管防露筒	4P079496-1		1	Page18
E63		1267154	Insulation tube evaporater header	蒸発器ヘッダー防露筒	4P073525-1		1	Page18
E64		1267161	Cushion material suction pipe(1)	吸入配管緩衝材 (1)	3P073468-1		1	Page18
E65		1267178	Cushion material suction pipe(2)	吸入配管緩衝材 (2)	3P073468-2		1	Page18
E66		1267224	Cushion material suction pipe(3)	吸入配管緩衝材 (3)	3P073468-3		1	Page18
E67		1267231	Cushion material suction pipe(4)	吸入配管緩衝材 (4)	3P073468-4		1	Page18
E68		1267248	Cushion material suction pipe(5)	吸入配管緩衝材 (5)	3P073468-5		1	Page18
E69		1267255	Thermal insulation tube	断熱筒 (吸入弁~庫外側)	4P081186-1		1	Page18
E70		1267262	Thermal insulation tube	断熱筒 (圧縮機根元~吸入弁)	4P081187-1		1	Page18
E71		1267279	Thermal insulation tube	断熱筒配管緩衝材	4P011309-2		3	Page15
E72		1267286	Thermal insulation tube	断熱筒配管緩衝材	4P011309-3		3	Page15,16
E73		1267293	Thermal insulation tube	断熱筒配管緩衝材	4P011309-4		2	Page14
E74		1267301	Tube cushion material	配管緩衝材	4PA50421-2		2	Page15
E76		1267325	Thermal insulation tube(drain outlet)	断熱筒 (ドレン入口管防露筒)	4P067126-1		1	Page18
E77		1267332	Thermal insulation tube(heat ex. inlet)	断熱筒 (熱交入口管防露筒)	4P067127-1		1	Page18
E78		1267349	Tube cushion material	配管緩衝材	4PA50427-1		2	Page16
E79		0024640	Rubber bush	ゴムブッシュ	R3713279-3		2	Page14
E80		1267356	Rubber bush	ゴムブッシュ	R3713279-4		2	Page14
E81		1267363	Rubber bush	ゴムブッシュ	R3713279-16		4	Page16
E82		1267370	Rubber bush	ゴムブッシュ	R3713279-2		2	Page14
E83		1267387	U-packing	UP字形パッキン	NA40014-4-500	L=500	3	Page14
E84	B	1267394	Heat shrinkable tube	熱収縮チューブ	4PA60531-2		2	Page15
E85	B	1267402	Heat shrinkable tube	熱収縮チューブ	4P074613-1	BLACK I.D. φ26.1,10.4	1	Page14
E86	B	1270453	Heat shrinkable tube	熱収縮チューブ	4P075241-1		1	Page15
E87		1270460	Insulation tape	不乾性型断熱テープ	3SA90102-3-KI		2	Page15
E88		1270477	Protection plate, solenoid valve	保護板	4P082209-1		1	Page15
E89		1270484	Mounting plate, solenoid valve	取付板	4P082208-1		1	Page15
C32		388339	Fixture	固定具	4PA11782-1		3	Page15

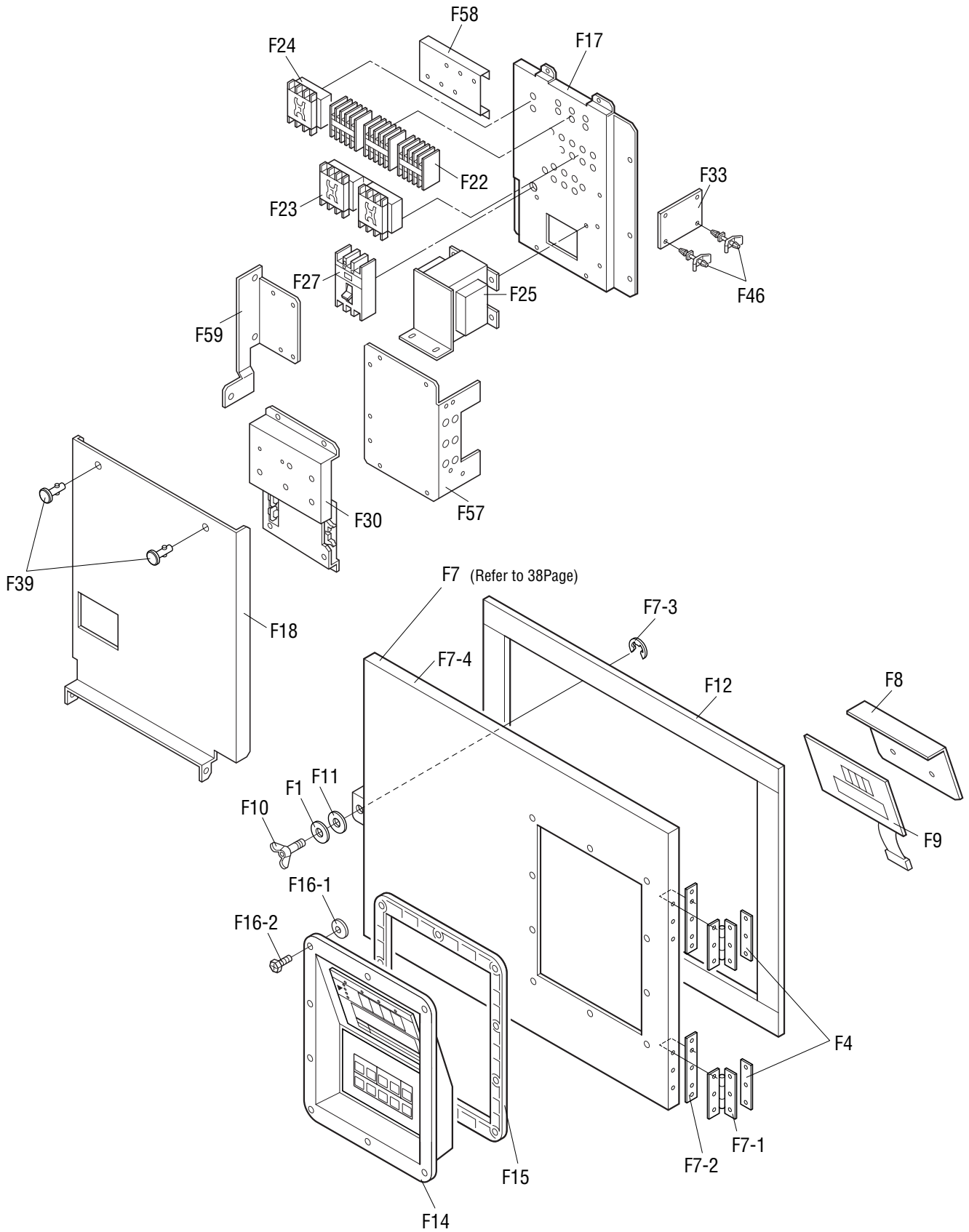

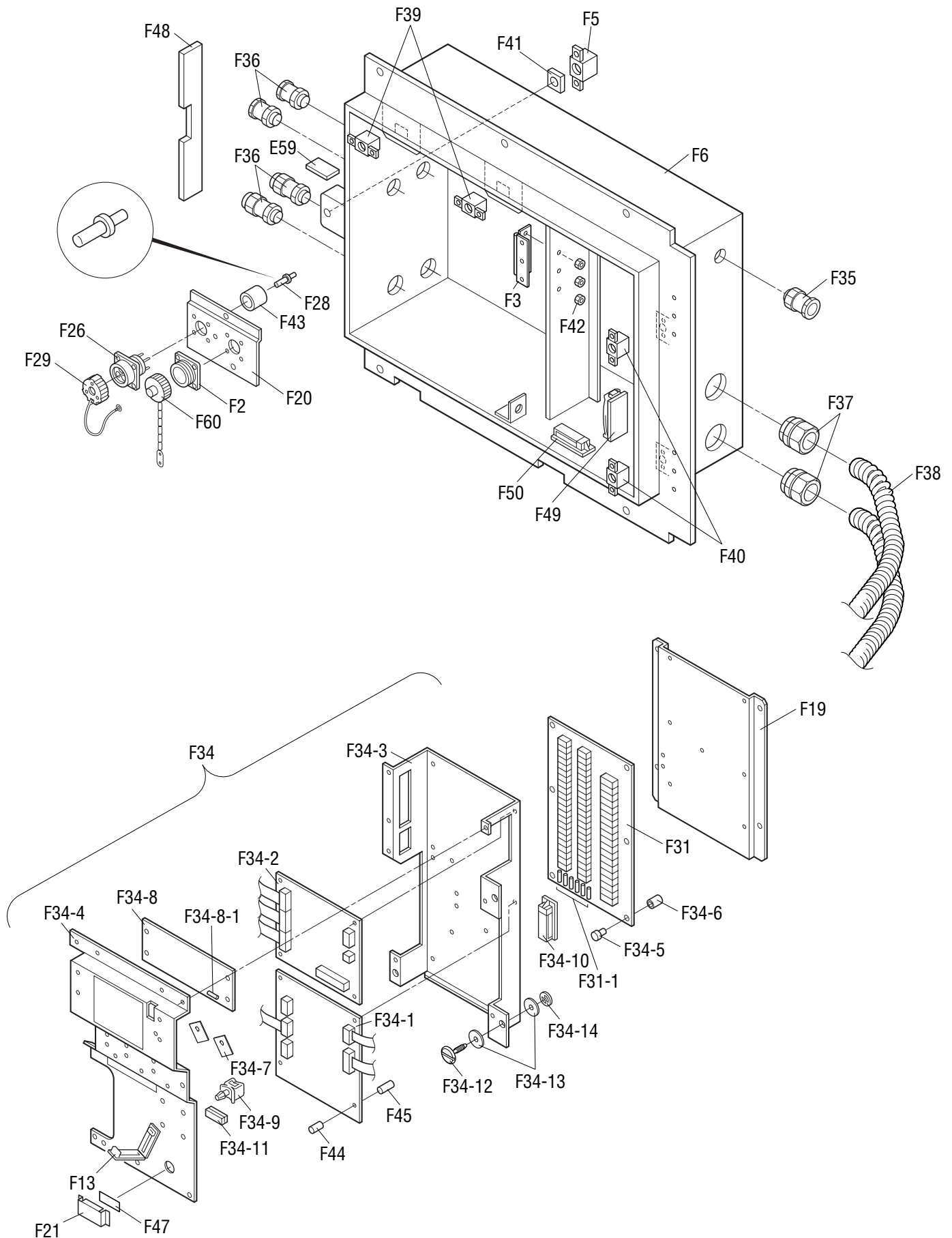

NO. 符号	INDEX	PARTS NO. 部品番号	PARTS NAME	部品名称	DWG. NO. 図面番号	TYPE SPECIFICATION 形式 仕様	QTY/UNIT 1台当たりの 所要数	REMARKS 備考
F1		844022	Plain washer	平座金	4SK07005-12		1	
F2	B	1110607	Monitoring receptacle	モニタリングレセプタクル本体	3P044703-1-KI		1	
F3		1136407	Hinge(control/box cover)	平蝶番(コントロールボックス蓋)	4P021346-1		1	
F4		1136414	Patch plate nut	当板ナット	4P044898-2		2	
F5		1267419	Plate nut hold plate	プレートナット押工板	4P010870-1		1	
F6		1267426	Control box welding ass'y	C. BOX溶接組立品	2P064233-2		1	
F7	C	1270491	Control box cover ass'y	コントロールボックス蓋組立品	2P059007-8		1	Refer to Page38
F7-1		1136407	Hinge(control/box cover)	平蝶番(コントロールボックス蓋)	4P021346-1		2	
F7-2		1136414	Patch plate nut	当板ナット	4P044898-2		2	
F7-3		1136445	Retaining ring	E 形止メ輪	4P016093-1		1	
F7-4		1270509	Control box cover welding ass'y	コントロールボックス蓋溶接組立品	3P068905-1		1	
F8		1267457	Operation display cover	操作表示カバー	3P078251-1	t1.0	1	
F9	A	1010815	Display board	表示基板	2P010368-2	EC9755-2	1	
F10		1136421	Wing bolt control box cover	蝶ボルト(コントロールボックス蓋)	4P010750-2		1	
F11		1136438	Insulation sheet	絶縁シート (C.BOX蓋)	4P016059-1		1	
F12		1136469	Rubber gasket	パッキン (C.BOX蓋)	4P003732-1		1	Refer to Page38
F13		1136539	Clamp	クランプ金具	4P015574-2		1	
F14	A	1256224	Control panel(with sheet key)	コントロールパネル(シートキー付)	3P035564-4		1	
F15		1128949	Packing	パッキン (樹脂パネル)	3P030317-1		1	
F16-1		0907062	Seal washer	シール座金 (ボンテッド座金)	4PA21941-5		10	
F16-2		1267488	Pan head machine screw	アプセット小ネジ	4P067677-1	M5×16	10	
F17		1267495	Mouting plate welding ass'y	機器取付板溶接組立品	3P078057-1		1	
F18		1267503	Blind plate(2)	機器取付板 (2)	2P078296-1	t1.2	1	
F19		1267510	Mounting plate, terminal board	端子基板取付板	3P044791-1		1	
F20		1267527	Fixing plate PC port	パソコンポート固定板	4P044311-1		1	
F21		1241138	Fixing plate, battery	固定板 (電池)	4P010920-1		1	
F22	A	1198931	Magnetic contactor(for Fans)	電磁接触器 (ファン用)	3P055568-1	24V PAK-6J31C	3	EFH,EFL,CFC
F23	A	1241493	Magnetic contactor(Phase correction contactor)	相順切換電磁接触器 (PCC)	3P071508-3	24V RSK-35J	1	PCC1,2
F24	A	1198917	Magnetic contactor(Compressor)	電磁接触器 (圧縮機)	3P055566-1	24V PAK35J-S536	1	CC
F25	A	1141377	Low frequency transformer	低周波変圧器	3PA50525-2		1	
F26	C	0991531	PC port connector	パソコンポートコネクタ	3P010803-1		1	
F27	A	0432986	Circuit breaker (CB)	ノーフェューズブレーカ (CB)	3PA42438-1		1	NF1
F28	C	1141144	Contact, receptacle	コンタクタ、レセプタクル用	3P010806-1	HD10	3	
F29		1267541	Cover ass'y, PC port	パソコンポートカバー組立品	3P010743-1		1	
F30	A	0991050	Printed circuit board ass'y(PT/CT board)	プリント基板ASSY(PT/CTボード)	2P017810-1		1	
F31	A	1256116	Terminal strip boaed	端子台基板	2P078284-1		1	
F31-1		0030652	Fuse, controller	制御用ヒューズ	4SA42006-4	250V 10A	6	
F33	A	0329679	Reverse phase protector	逆相保護装置 (RPP)	3SA42153-1	346-440V	1	
F34	A	1241347	Controller ass'y	コントローラ組立品	3P065573-1		1	
F34-1	A	1250776	CPU board ass'y	プリント基板ASSY	2P065387-1	EC0076	1	

NO. 符号	INDEX	PARTS NO. 部品番号	PARTS NAME	部品名称	DWG. NO. 図面番号	TYPE SPECIFICATION 形式 仕様	QTY/UNIT 1台当たりの 所要数	REMARKS 備考
F34-2	A	0954594	I/O board	I/O ボード	2P010367-1		1	
F34-3		1267558	Bottom plate, contoller	コントローラ底板	2P049529-2	t1.2	1	
F34-4	B	1267565	Controller cover	蓋 (コントローラ)	2P062832-1	t1.2	1	
F34-5		1099940	Support bushing	プリント基板サポートブッシュ	MI49531-11		14	
F34-6		1099957	Support color	プリント基板サポートカラー	MI49531-13		14	
F34-7		1267572	Rubber transistor	放熱用ゴムトランジスタ	4P005330-1		2	
F34-8	A	1250783	PC board for suction modulating valve	プリント基板A S S Y (吸入制御弁用)	3P065441-1	EC0058	1	
F34-8-1		0445432	Fuse, controller	制御用ヒューズ	4SA42006-3	250V 5A	1	
F34-9		1267596	Locking wire saddle	ロックングワイヤサドル	4P015570-2	LWS	4	
F34-10		1267604	Flat cable clamp	フラットケーブルクランプスナップタイプ	4P015573-1		1	
F34-11		1136539	Clamp	クランプ金具	4P015574-2		1	
F34-12		1267611	Speed bolt(M6)	スピードボルト (M6)	4P048680-3	M6X20(S)	2	
F34-13		860005	Washer, speed bolt	スピードボルト用座金	R4713334		4	
F34-14		840002	Drop out prevention washer	脱落防止座金	R4718607-6		2	
F35		1267628	Wire(wire ground)	電線 (電線グラウンド)	4P067662-1		1	
F36		1267635	Wire(wire ground)	電線 (電線グラウンド)	4P067663-1		4	
F37		1267642	Flexible tube connector	フレキシブル管用コネクタ	4P010926-6		2	
F38		1267659	Flexible wire tube	フレキシブル電線管	3P010927-62		2	
F39		1267666	Quick fastener	クイックファスナー	4P064642-1		2	
F40		860015	Universal nut	自在ナット	R4713188-1		2	
F41		1267673	Plate nut, control box cover	プレートナット(コントロールボックス蓋)	4P010869-1	ウイットネジ W1/2-12	1	
F42		833302	Nylon nut	ナイロンナット	R4716460-1	M4	3	
F43		1267680	Vinyl tube	ビニールチューブ	4P044312-1	TRANSPARENT	1	
F44		1099940	Support bushing, PCB	プリント基板サポートブッシュ	MI49531-11		7	
F45		1099957	Support color, PCB	プリント基板サポートカラー	MI49531-13		7	
F46		981616	Locking card spacer	ロックングカードスペーサー	R3428091-3	KGLS-8S	4	
F47		1267697	Cushion rubber	緩衝ゴム電池用	4P015624-1		1	
F48		1267705	Packing, control box front panel	パッキン(コントロールボックス前板)	4P011315-1		1	
F49		1136539	Clamp	クランプ金具	4P015574-2		2	
F50		1267712	Clamp	クランプ金具	3P049495-1		1	
F57		1267774	Set plate(PT/CT board)	機器取付板 (P T / C T ボード)	3P071688-1	t1.6	1	
F58		1267781	Mounting plate, elect components	電装品取付板	4P064227-1	t=1.2	1	
F59		1267798	Set plate(breaker)	機器取付板 (ブレーカ)	3P064278-1	t=2.3	1	
F60	C	1267806	Cap, monitoring receptacle	モニタリングレセプタクルキャップ	3P044703-1-KA		1	
E59		1267116	Packing for control box front plate	パッキン (C. B O X 前板 (左))	4P070346-2		1	

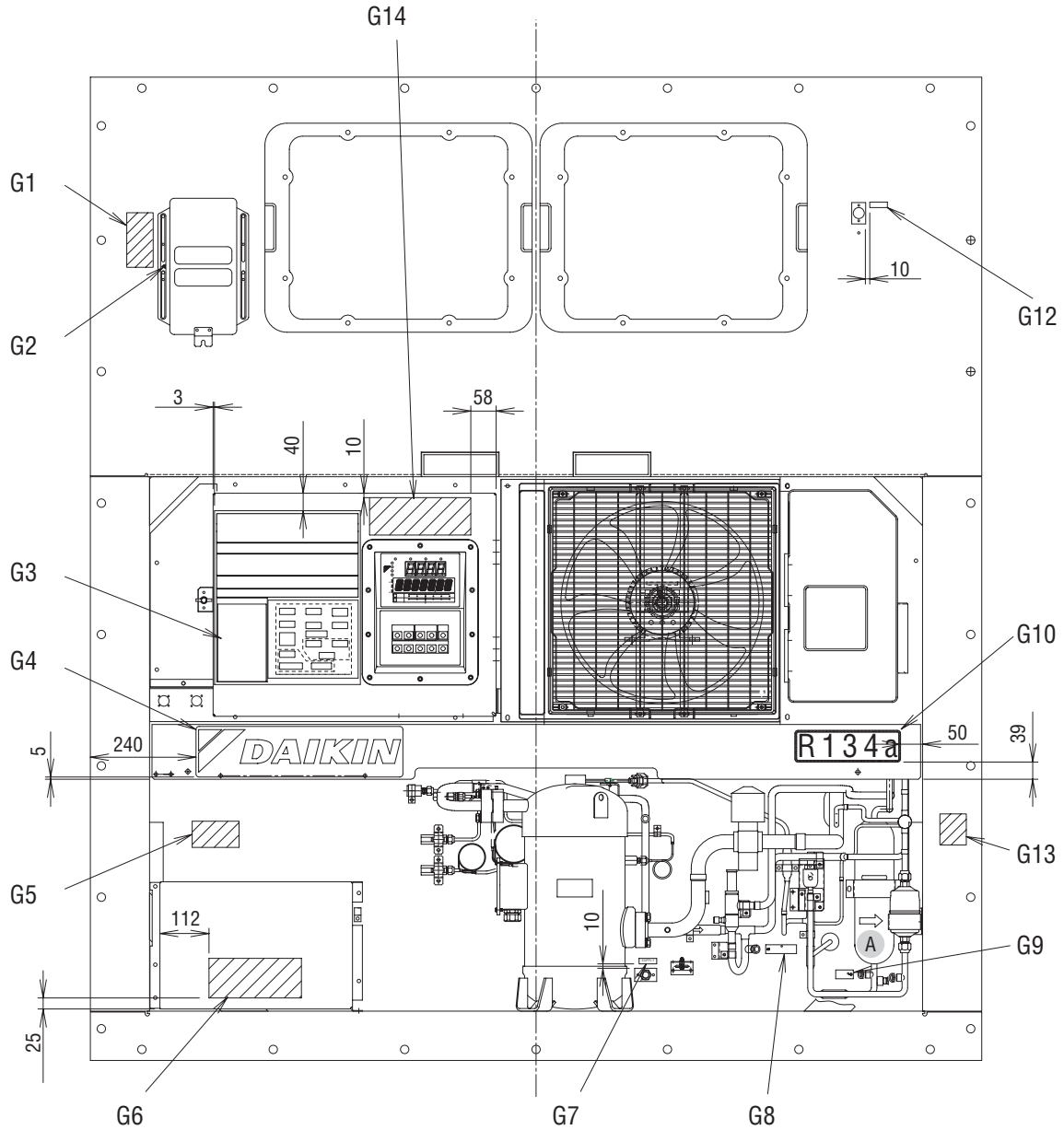

矢視A(View A)

電磁弁配置銘板貼付位置詳細
(Detail location of nameplate, solenoid valve)

コントロールボックス内部(Inside of Control Box)

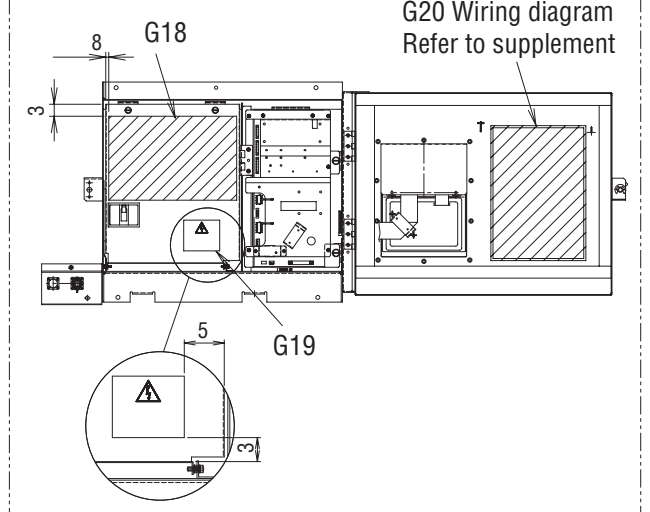
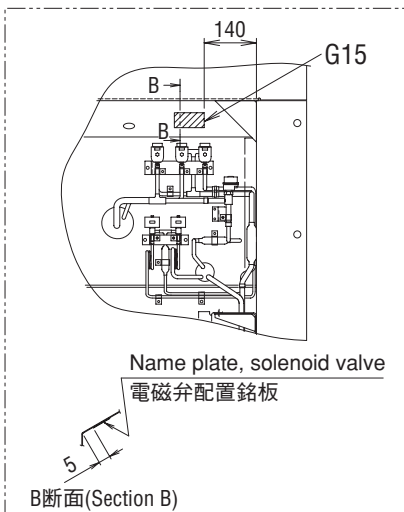
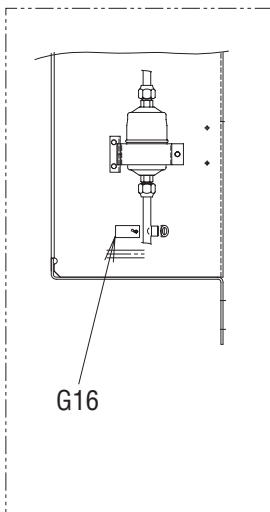

NO. 符号	INDEX	PARTS NO. 部品番号	PARTS NAME	部品名称	DWG. NO. 図面番号	TYPE SPECIFICATION 形式 仕様	QTY/UNIT 1台当たりの 所要数	REMARKS 備考
G1		1267945	Name plate, ventilator	換気口銘板	4P069720-1	English	1	
G2		1267952	Name plate, ventilator arrow	ベンチレータ矢印銘板	4P018502-1		1	
G3		1267969	Name plate, operation	操作銘板	1P083255-1	English/Japanese	1	Refer to Page38
G4		1093144	Name plate, brand name	意匠銘板	4P039685-1	English	1	Refer to Page39
G5		1267983	Name plate, unit performance	機械銘板	3P066701-1	English	1	
G6		1267990	Caution label, service port	サービスポート取扱注意銘板	3P083395-1	English/Japanese	1	
G7		1268001	Name plate, supply	指示銘板(SUPPLY銘板)	4PA55459-2	English	1	
G8		1268018	Name plate, service port	サービスポート銘板(真空引き専用)	4P083314-1	English/Japanese	1	
G9		1268102	Name plate, service port	サービスポート銘板(レシーバ出口)	4P083314-2	English	1	
G10		1178843	Name plate, refrigerant	冷媒銘板	3P009750-1		1	Refer to Page39
G12		1268133	Name plate, return	指示銘板(RETURN銘板)	4PA55459-1	English	1	
G13		1270516	Name plate, additional defrigerant charge	冷媒追加充填銘板	3P084351-1	English/Japanese	1	
G14		1268140	Name plate, sheet key operation	シートキー操作銘板(自動ボンブダウ)	3P083304-1	English/Japanese	1	Refer to Page38
G15		1268157	Name plate, solenoid values	電磁弁配置銘板	4P082158-1	English	1	
G16		1268164	Name plate, service port	サービスポート銘板(ドライヤ入口)	4P083314-3	English	1	
G18		1268188	Name plate, emergency	エマージェンシー銘板	2P083292-1	English/Japanese	1	
G19		1181267	Caution label, high voltage	高電圧注意銘板	4P010095-1	English	1	
G20			Name plate, wiring diagram	配線図銘板		補足版参照の事		Refer to supplement

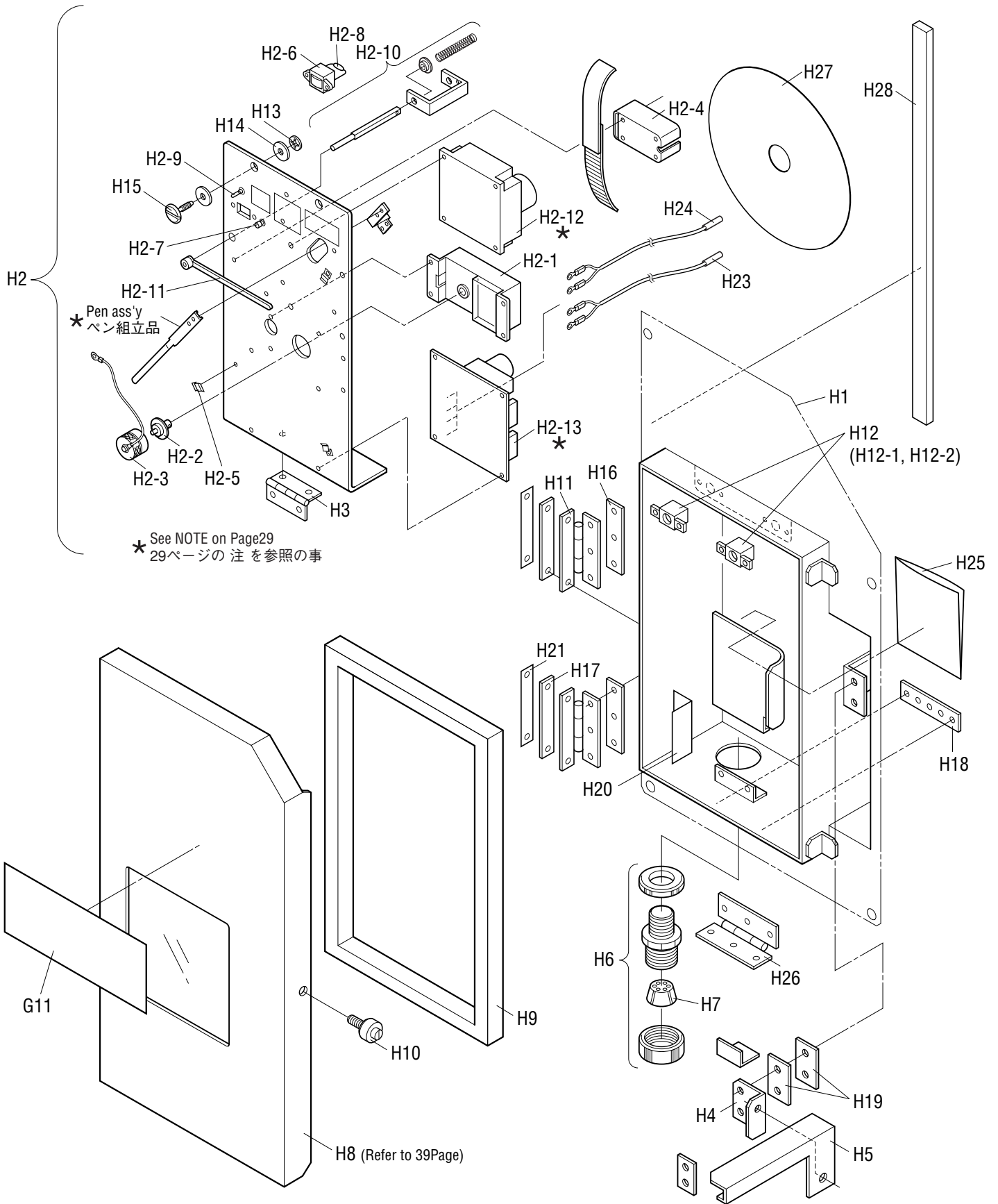

NO. 符号	INDEX	PARTS NO. 部品番号	PARTS NAME	部品名称	DWG. NO. 図面番号	TYPE SPECIFICATION 形式 仕様	QTY/UNIT 1台当たりの 所要数	REMARKS 備考
H1		1267813	Recorder box ass'y	レコーダ BOX溶接組立図	2P048643-4		1	
H2	A	1267820	Temperature recorder	温度記録計	2P021722-10		1	
H2-1	B	0143495	Quartz motor	クォーツ時計	3PA20194-2		1	
H2-2	B		Shaft, chart	チャート軸受け		4-E4191P1 BS	1	
H2-3		0037855	Chart stopper ass'y	チャート押さえ組立	4PA20211-1	A5052BP	1	
H2-4			Battery holder	電池ホルダー		4-E4374C1 ABS樹脂6Z680	1	
H2-5			Holder	ホルダー		RH14	3	
H2-6	B		Indicator	メーター		4-E6827P1 MODEL250	(1)	
H2-7	B		Push button switch	押しボタンスイッチ		4-E4777C1	(1)	
H2-8	B		Resistor	抵抗		TS60E-B3.9K	(1)	
H2-9	B		Toggle switch	トグルスイッチ		M2018G	(1)	
H2-10			Stopper	ストッパー		4-E4752C1	1	
H2-11	C		Lever	レバー		4-E4161C1 SUS27	1	
H2-12	B		Servo unit	サーボユニット		3-C5575C3	1	
H2-13	B		PC board ass'y	プリント基板組立品		3-C7505C1	1	
<p>Note:The recording-pen assembly, H2-12 servo-unit and H2-13 PCB assembly have been adjusted in the factory as one set. Accordingly, individual assembly can not be adjusted separately. When any component in those assembly should faulty, replace the entire H2 temperature recorder as a set.</p> <p>注：ペン組立品、H2-12(サーボユニット)及びH2-13(プリント基板組立品)は、一体で工場にて調整されています。従って、現地での単体での調整は不可能です。この部品が不具合の場合は、H2の温度記録計一式で交換してください。</p>								
H3		1136104	Hinge	平蝶番	4P043349-1		1	
H4		1267837	Mounting plate, quick lock lever	ワンタッチ金具取付板	4P067761-1		1	
H5		1136111	Quick lock lever	ワンタッチ金具	4P043377-1		1	
H6		0773771	Cable gland	電線グラント	3PA37599-10	SCL-22B	1	
H7		1267844	Grand rubber bush	グラントゴムブッシュ	4P032156-1		1	
H8		1267851	Cover(recorder)	蓋 (レコーダ)	1P054302-1		1	Refer to Page39
H9		1267868	Packing (recorder cover)	パッキン (蓋)	4P063866-1		1	Refer to Page39
H10		1267875	Roller	ワンタッチ金具用ローラ	3P054321-1		1	
H11		1136096	Hinge, cover	蓋締付蝶番	4P043069-1		2	
H12		860015	Universal nut	自在ナット	R4713188-1		2	
H12-1			Body	本体	R4713188-1-KA		2	
H12-2			Plate nut	プレートナット	R4713188-1-KI		2	
H13		840002	Drop out prevention washer	脱落防止座金	R4718607-6		2	
H14		860005	Washer, speed bolt	スピードボルト用座金	R4713334		4	
H15		1267611	Speed bolt	スピードボルト (M6)	4P048680-3	M6X20(S)	2	
H16		874014	Patch plate nut	当板ナット	R3715992-33		2	
H17		1267899	Patch plate nut	当板ナット	4P066242-1		2	
H18		1136414	Patch plate nut	当板ナット	4P044898-2		1	
H19		0907101	Spacer	スペーサ	4PA51278-1		2	
H20		1267907	Sealing material	シール材	4P049613-1		1	
H21		1267914	Insulation sheet	絶縁シート	4P066250-1	t0.075±0.01	2	

● When ordering the parts whose No. are not shown in the PARTS NO. column, be sure to describe DWG. NO..

● 部品番号欄が空白になっている部品は、図面番号で、指示願います。

NO. 符号	INDEX	PARTS NO. 部品番号	PARTS NAME	部品名称	DWG. NO. 図面番号	TYPE SPECIFICATION 形式 仕様	QTY/UNIT 1台当たりの 所要数	REMARKS 備考
H23	A	0798307	Sensor (RSS)	センサー (RSS)	3PA61769-4	ST9503-4 (Green, Green)	1	
H24	A	0798282	Sensor (RRS)	センサー (RRS)	3PA61769-2	ST9503-2 (Blue, Blue)	1	
H25		1267921	Protection sheet, recording chart	保護シート	4P015666-1		1	
H26		1136407	Hinge(recorder/box cover)	平蝶番(レコーダボックス蓋)	4P021346-1		1	
H27	C	0581213	Recording chart	記録紙	3PA43798-1		1	
H28		1270523	Sealing material	シール材	4P067048-1		1	
G11		1268126	Name plate, recorder box	レコーダーボックス銘板	3P010003-1	English/Japanese	1	Refer to Page39

NO. 符号	INDEX	PARTS NO. 部品番号	PARTS NAME	部品名称	DWG. NO. 図面番号	TYPE SPECIFICATION 形式 仕様	QTY/UNIT 1台当たりの 所要数	REMARKS 備考

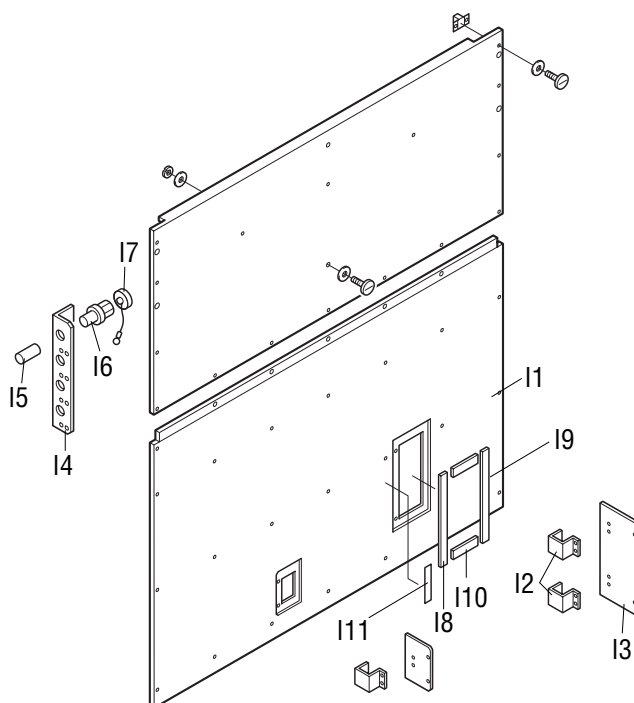

NO. 符号	INDEX	PARTS NO. 部品番号	PARTS NAME 部品名称	DWG. NO. 図面番号	TYPE SPECIFICATION 形式 仕様	QTY/UNIT 1台当たりの 所要数	REMARKS 備考
I1		1266454	Rear plate(lower), USDA 裏板(下) USDA、バッフルプレート穴	2P081946-1		1	
I2		1135125	Hinge 蝶番	3P043374-1		2	
I3		1266500	Inspection door(USDA) 点検蓋 (USDA)	4P072709-1	t2.0	1	
I4		1266531	Mounting plate, receptacles レセプタクル取付板	3P053162-1		1	
I5		1266548	Vinyl tube ビニールチューブ	4P039446-1	TRANSPARENT	3	
I6		0991548	Receptacle レセプタクルSHELL	3PA47173-1		3	
I7		0767226	Cap, receptacle キャップ	4PA47172-1		3	
I8		1267022	Sealing material(USDA patch plate 3) シール材 (USDA 当板3)	4P072739-1	t5.0	1	
I9		1267039	Sealing material(USDA patch plate 2) シール材 (USDA 当板2)	4P072738-1	t5.0	1	
I10		1267046	Sealing material(USDA patch plate 1) シール材 (USDA 当板1)	4P072737-1	t5.0	2	
I11		1268171	Name plate, USDA USDA銘板	3P009424-1	English	1	

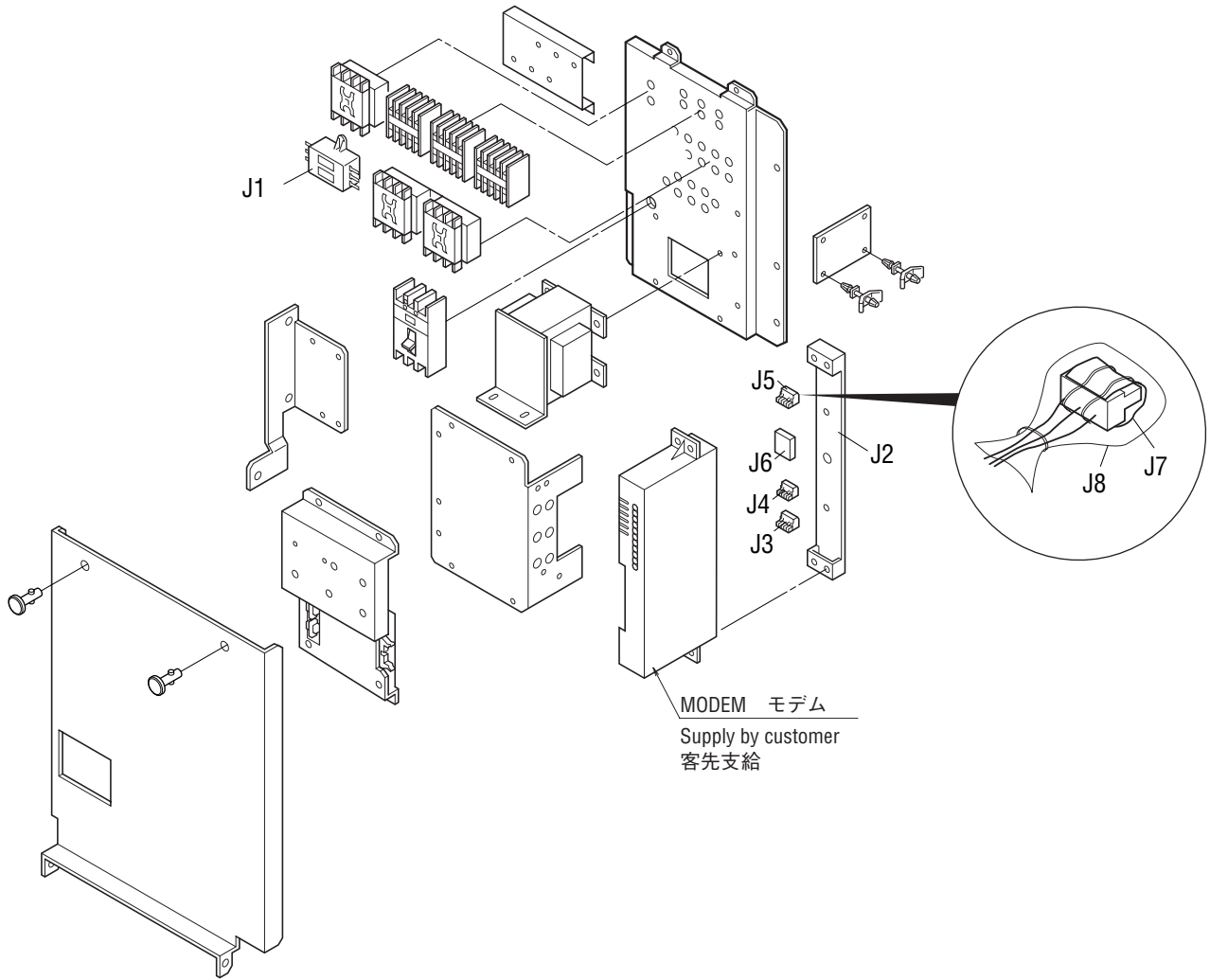

NO. 符号	INDEX	PARTS NO. 部品番号	PARTS NAME	部品名称	DWG. NO. 図面番号	TYPE SPECIFICATION 形式 仕様	QTY/UNIT 1台当たりの 所要数	REMARKS 備考
J1	B	0954640	Noise filter	ノイズフィルタ	2PA51273-1	ZAC2206-11	1	
J2		1267729	Mounting plate(modem)	取付板 (モデム)	4P026167-1	t1.6	1	
J3		1267736	Connector, PCB(female)	プリント基板用コネクタ(メス)	3P012038-3	BLA3	1	
J4		1267743	Connector terminal strip	コネクタ端子台	3P010371-7		1	
J5		1267750	Connector, PCB(female)	プリント基板用コネクタ(メス)	3P012038-7	BLA7	1	
J6		0468839	Noise filter(for modem)	ノイズフィルター (モデム用)	3EA76001-1		1	
J7		1267767	CR rubber	CRゴム	4P027629-1		1	
J8		0311250	Vinyl bag	ビニール袋	RI40021-5		1	

1. Indoor fan guard

1. 庫内ファンガード

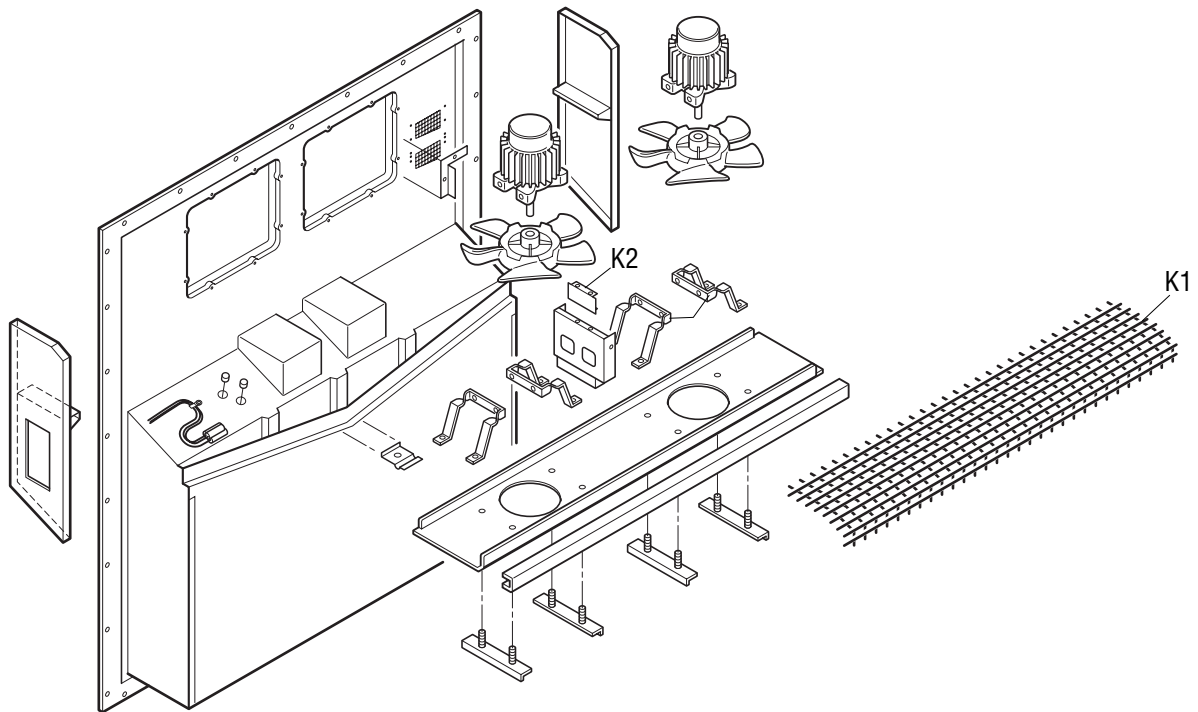

2. Evaporator coil

2. 蒸発器コイル組立品

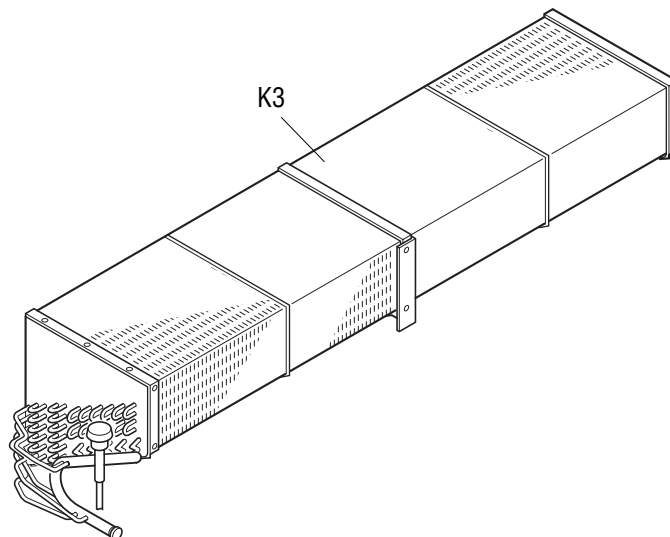

NO. 符号	INDEX	PARTS NO. 部品番号	PARTS NAME	部品名称	DWG. NO. 図面番号	TYPE SPECIFICATION 形式 仕様	QTY/UNIT 1台当たりの 所要数	REMARKS 備考
K1		1266492	Fan cover	庫内ファンカバー	2P072700-1		1	
K2		1266423	Fixing plate, fan cover	ファンカバー固定板 (3)	3P044719-3		1	
K3		1261031	Evaporator ass'y	蒸発器組立品	2P033114-2	CRB-LXE10E4	1	With precoated fan クリア塗装有り

1. Resin clamp

1. 樹脂バンド

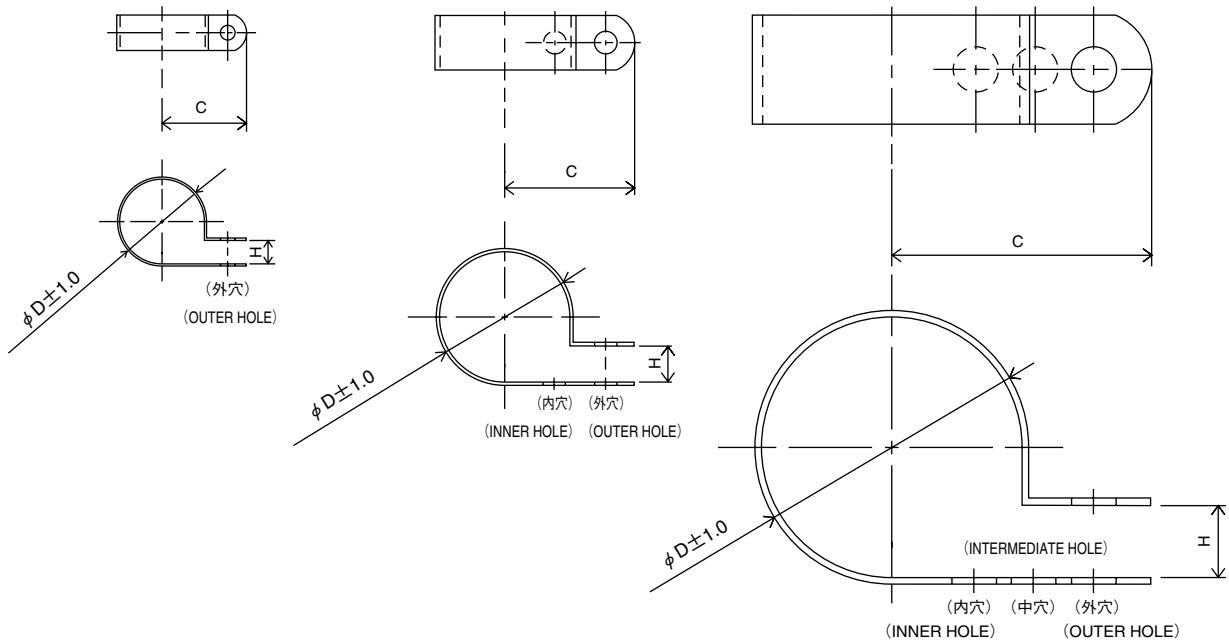

NO. 符号	PARTS NO. 部品番号	PARTS NAME	部品名称	DWG NO. 図面番号	SIZE サイズ			QTY 使用個数
					D	C	H	
E9	0118273	Resin clamp	樹脂バンド	NE41015-2	6.8	15.8	4.8	4
E11	0944528	Resin clamp	樹脂バンド	NE41015-7	19.8	24.6	7.9	4
E10	1222764	Resin clamp	樹脂バンド	NE41015-9	26.9	27.8	7.9	1
E12	0142492	Resin clamp	樹脂バンド	NE41015-10	29.2	29.4	7.9	3
E14	1266788	Resin clamp	樹脂バンド	NE41015-12	39.4	34.2	9.5	7

2. Tube clamp

2. 管止金

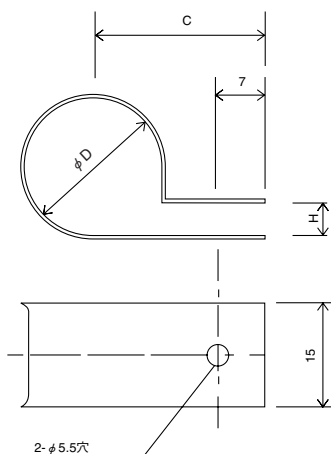

NO. 符号	PARTS NO. 部品番号	PARTS NAME	部品名称	DWG NO. 図面番号	SIZE サイズ			QTY 使用個数
					D	C	H	
E15	0782775	Tube clamp	管止金	NE31016-51	10	20	3	5
E16	0702382	Tube clamp	管止金	NE31016-52	12	21	3	5
E17	0414421	Tube clamp	管止金	NE31016-53	14	22	3	2
E18	0700090	Tube clamp	管止金	NE31016-54	16	23	4	1
E19	1266795	Tube clamp	管止金	NE31016-55	18	24	5	3
E20	0016290	Tube clamp	管止金	NE31016-56	20	25	5	3
E22	1266810	Tube clamp	管止金	NE31016-57	22	26	5	2
E27	1266858	Tube clamp	管止金	NE31016-59	26	28	5	1
E29	1266865	Tube clamp	管止金	NE31016-60	28	29	5	1
E6	1270439	Tube clamp	管止金	NE31016-61	30	30	5	2
E21	1266803	Tube clamp	管止金	NE31016-70	8.5	20	1	9

3. Cushion rubber for pipe clamp

3. 管止金用緩衝ゴム

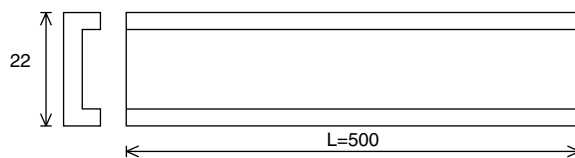

NO. 符号	PARTS NO. 部品番号	PARTS NAME	部品名称	DWG NO. 図面番号	REMARKS 備考
E35	1266911	Cushion rubber	管止金用緩衝ゴム	NE41013-3-500	Cut to suit pipe size. 配管サイズに合わせて切って使用のこと

1. Parts recommended to be ordered together with packing, gasket, sealing material and name plate
1. 発注の際にパッキングやシール材、銘板等の同時発注を推奨する部品

For ordering following spare parts, we recommend that you order the following packing, gasket, sealing material and name plate together at the same time.

上記のサービス扉やボックスカバーを発注の際には、下記のパッキングを同時に発注することをおすすめします。

(1) Service door

(1) サービス扉

NO. 符号	PARTS NO. 部品番号	PARTS NAME	部品名称	DWG NO. 図面番号	REMARKS 備考
A4	0980423	Access panel ass'y	サービス扉組立品	1P006678-1	(Without cushion and sealing material) (クッション材、シール材なし)
A5	1266207	Cushion material	クッション材	3P033608-1	
A6	1196113	Sealing material	シール材	3P001640-1	

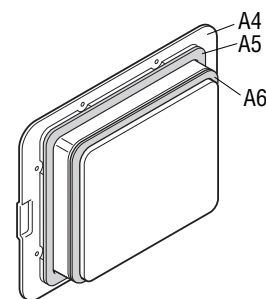

(2) Control box cover

(2) コントロールボックスカバー

NO. 符号	PARTS NO. 部品番号	PARTS NAME	部品名称	DWG NO. 図面番号
F7	1267433	Control box cover ass'y	コントロールボックスフタ組立品	2P059007-7
F12	1136469	Rubber gasket	ゴムガスケット	4P003732-1
G3	1267969	Name plate, operation	操作銘板	1P083255-1
G14	1268140	Name plate, sheet key operation	シートキー操作銘板	3P083304-1

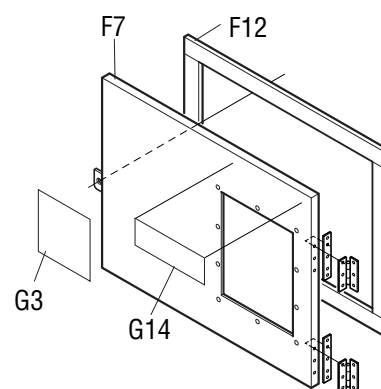

※Wiring diagram name plate is different by model.

※電気配線図銘板は機種により異なります。

(3) Recorder box cover (Option)

(3) レコーダボックスカバー (オプション)

NO. 符号	PARTS NO. 部品番号	PARTS NAME	部品名称	DWG NO. 図面番号
H8	1267851	Cover (recorder)	レコーダボックスフタ	1P054302-1
H9	1267868	Packing (recorder cover)	パッキン (フタ)	4P063866-1
G11	1268126	Name plate, recorder box	レコーダーボッ クス銘板	3P010003-1

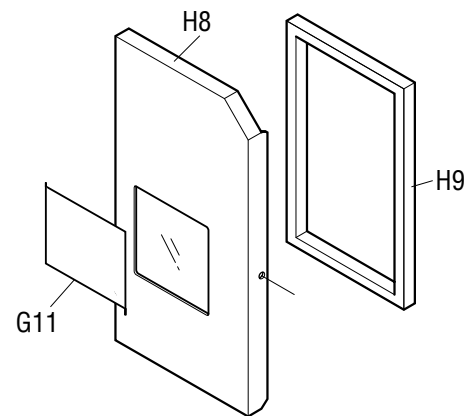

(4) Ventilation cover

(4) 換気口蓋

NO. 符号	PARTS NO. 部品番号	PARTS NAME	部品名称	DWG NO. 図面番号
A19	1266120	Ventilation cover	換気口蓋	3P067053-1
A20	1266221	Sealing material (access panel)	シール材 (換気口)	4P016185-1

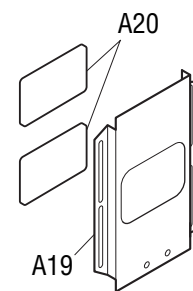

(5) Front plate (CA)

(5) 前板 (CA)

NO. 符号	PARTS NO. 部品番号	PARTS NAME	部品名称	DWG NO. 図面番号
A15	1270338	Front plate (CA)	前板 (CA)	2P061345-1
G4	1093144	Name plate, brond name	意匠銘板	4P039685-1
G10	1178843	Name plate, refrigerant	冷媒銘板	3P009750-1

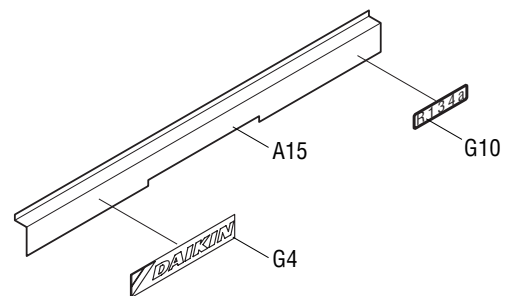

2. Order for motorized valve, solenoid valve and pressure regulating valve

2. 電動弁・電磁弁・圧力調整弁の発注

Refer to the following table for the name, main body, solenoid coil and ass'y of solenoid valves etc. applied to this model.

この機種に使用されている電磁弁等の名称と本体・コイル・組立品は下記のとおりです。

	Body/Coil 本体/コイル	NO. 符号	PARTS NO. 部品番号	PARTS NAME	部品名称	DWG NO. 図面番号	Common Parts 共通部品		
							NEV-803DXF	NEV-202DXF	NEV-MOAB507C
1.EV	本体 Body	B7-3	1256495	Electronic expansion valve body	電子膨張弁本体	2SA50010-2-KU			
	コイル Coil	B20	0954619	Electronic expansion valve coil	電子膨張弁コイル	2P010454-1			
2.HSV	本体 Body	B7-4	0944566	Hot gas solenoid valve body	ホットガス電磁弁本体	R3305118-1	○		
	コイル Coil	B7-5	0955287	Hot gas solenoid valve coil	ホットガス電磁弁コイル	3P010453-1			○
3.DSV	本体 Body	B7-4	0944566	Defrost bypass solenoid valve body	デフロストバイパス電磁弁本体	R3305118-1	○		
	コイル Coil	B7-5	0955287	Defrost bypass solenoid valve coil	デフロストバイパス電磁弁コイル	3P010453-1			○
4.BSV	本体 Body	B7-4	0944566	Gas bypass solenoid valve body	ガスバイパス電磁弁本体	R3305118-1	○		
	コイル Coil	B7-5	0955287	Gas bypass solenoid valve coil	ガスバイパス電磁弁コイル	3P010453-1			○
5.ESV	本体 Body	B7-6	0088738	Economizer solenoid valve body	エコノマイザー電磁弁本体	R3305099-1-KI		○	
	コイル Coil	B7-5	0955287	Economizer solenoid valve coil	エコノマイザー電磁弁コイル	3P010453-1			○
6.ISV	本体 Body	B7-6	0088738	Injection solenoid valve body	インジェクション電磁弁本体	R3305099-1-KI		○	
	コイル Coil	B7-5	0955287	Injection solenoid valve coil	インジェクション電磁弁コイル	3P010453-1			○
7.LSV	本体 Body	B4-5	0944566	Liquid solenoid valve body	液電磁弁本体	R3305118-1	○		
	コイル Coil	B4-6	0955287	Liquid solenoid valve coil	液電磁弁コイル	3P010453-1			○
8.SMV	組立品 Ass'y	B8-1	1254538	Suction modulating Valve	吸入比例弁組立品	2P078385-1			Note 1 注 1
9.DPR	組立品 Ass'y	B3-4	1241361	Discharge pressure regulating valve	吐出圧力調整弁	3P074558-1			

Note 1 : Refer Page 6 and 7 for detail parts of suction modulating valve.

注 1 : SMV（吸入比例弁）の詳細部品はP.6、7を参照ください。

3. Order for pressure trasducer

3. 圧力センサーの発注

Refer to the following table for the pressure transducer applied to this model.

For ordering pressure transducer, we recommend that you order the following best shrinkable tube together at the same time.

この機種に使用している圧力センサーは下記の通りです。

圧力センサー発注の際は、下記の熱収縮チューブを同時に発注することをおすすめします。

呼称名	NO. 符号	PARTS NO. 部品番号	PARTS NAME	部品名称	DWG NO. 図面番号	TYPE 形式	REMARKS 備考
HPT	B16	0797234	High pressure transducer	高压圧力センサー	4PA60522-1	SPCH01	
	B17	1011058	Cable, high pressure transducer	高压圧力センサー用ケーブル	3P008835-1		
LPT	B15	0797241	Low pressure transducer	低压圧力センサー	4PA60524-1	SPCL02	
	B18	1011065	Cable, low pressure transducer	低压圧力センサー用ケーブル	3P008835-2		
	B84	1267394	Heat shrinkable tube	熱収縮チューブ	4PA60531-2		Must be applied when replacing above sensors. 上記圧力センサー交換時使用の事。

4. Order for temperature sensor

4. 温度センサーの発注

Refer to the following table for temperature sensors applied to this model.

この機種に使用されている温度センサーは下記の通りです。

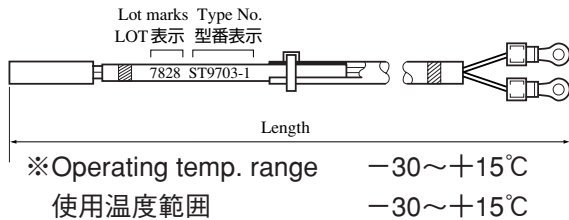
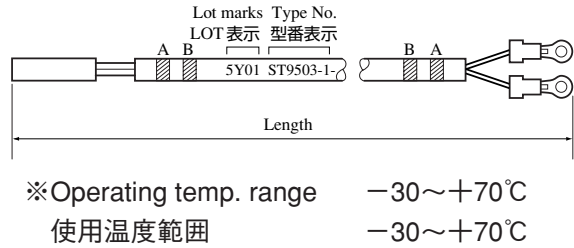
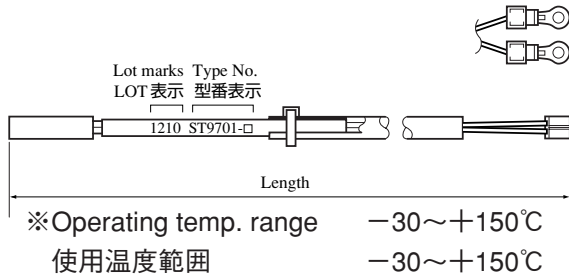

※1 Location 取付場所

Indoor A : Indoor supply air side

Indoor B : Indoor return air side

庫内A : 庫内吹出空気側

庫内B : 庫内吸込空気側

呼称	NO. 符号	PARTS NO. 部品番号	PARTS NAME 部品名称	DWG. NO. 図番	TYPE 形式	WIRE COLOR 配線色		LENGTH 全長mm	※1 LOCATION 取付場所	TEMPORALY EXCHANGABILITY 緊急時互換性
						A	B			
1. SS	C24	0798299	Supply air temp. sensor	3PA61769-3	ST9503-3	green 緑	- -	3200	Indoor A 庫内A	○
2. DSS	C25	0798770	Data recorder supply air temp. sensor	3PA61769-8	ST9503-8	green 緑	Red 赤	3200	Indoor A 庫内A	○
3. RS	C26	0798275	Return air temp. sensor	3PA61769-1	ST9503-1	Blue 青	- -	3200	Indoor B 庫内B	○
4. DRS	C27	0798732	Data recorder return air temp. sensor	3PA61769-7	ST9503-7	Blue 青	Red 赤	3200	Indoor B 庫内B	○
5. EIS	D4	0983376	Evaporator inlet temp. sensor	3P012118-1	ST9703-1	Brown 茶	- -	3200	Indoor EVP. 庫内蒸発器	
6. EOS	D5	0798314	Evaporator outlet temp. sensor	3PA61769-5	ST9503-5	Yellow 黄	- -	3200	Indoor EVP. 庫内蒸発器	○
7. DCHS	B11	0983321	Discharge pipe temp. sensor	3SA48009-10	ST9701-10	-	-	2800	Outdoor 庫外	
8. AMBS	B12	0798321	Ambient air temp. sensor	3PA61769-6	ST9503-6	- -	- -	3200	Outdoor 庫外	○
9. SGS	B13	0983338	Compressor suction gas temp. sensor	3PA61769-9	ST9503-9	White 白	- -	3200	Outdoor 庫外	○
10. RSS	G23	0798307	Recorder supply air sensor	3PA61769-4	ST9503-4	green 緑	green 緑	3200	Indoor A 庫内A	○
11. RRS	G24	0798282	Recorder return air sensor	3PA61769-2	ST9503-2	Blue 青	Blue 青	3200	Indoor B 庫内B	○

1. Tools for emergency operation

1. 緊急運転用工具

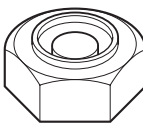
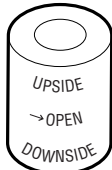
NO. 符号	PARTS NO. 部品番号	PARTS NAME	部品名称	DWG NO. 図面番号	USE 用途	ILLUSTRATION 姿図
-	1080263	Emergency coil cap	エマージェンシー コイルキャップ	3P017370-1	For electronic expansion valve 電子膨張弁用	
-	1270530	Emergency magnet	エマージェンシー マグネット	2P078385-2	Suction modulating valve 吸入比例弁用	

(See Service Manual for application.)

(使用方法はサービスマニュアルを参照ください。)

2. Personal computer cable (for DCCS)

2. パソコンケーブル (DCCS用)

The following parts are connector cables required to exchange information between the refrigeration unit and personal computer. The table below describes parts required to apply to Model LXE-C, -D, and -E new model.

下記の部品は冷凍ユニットとパソコンの情報交換に必要なコネクタ、ケーブル類です。LXE-C型、D型、及び新機種E型対応に必要な部品を掲載しています。

[TYPE A]タイプA

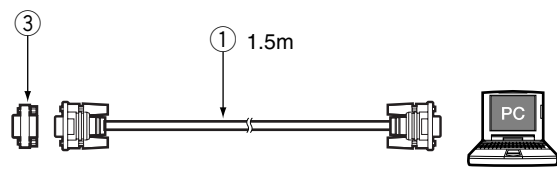
LXE10C LXE10CA LXE10D for MOL	LXE10C LXE10CA MOL用LXE10D	
(Receptacle) RS232C (Female) on the controller	(レセプタクル) RS232C (メス) コントローラー側	

[TYPE B]タイプB

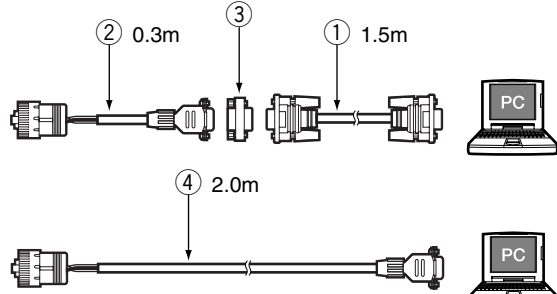
LXE10D LXE10E	LXE10D LXE10E	
(Receptacle) Water proof type on the unit	(レセプタクル) コンテナ冷凍機 ユニットの防水型	

(1) Parts No.

(1) 部品番号

NO. 符号	PARTS NO. 部品番号	PARTS NAME	部品名称	REMARKS 備考
①	Local supply 市販品	Connection cable (reverse)	接続ケーブル (リバース)	RS232C reverse (cross) type RS232Cリバース (クロス) 型
②	9993324	Connection cable	接続ケーブル	
③	Local supply 市販品	Adapter (gender changer)	アダプター (ジェンダーチェンジャー)	D-sub 9P, Male-Male Dサブ9ピン、オス-オス
④	1087149	Connection cable	接続ケーブル	

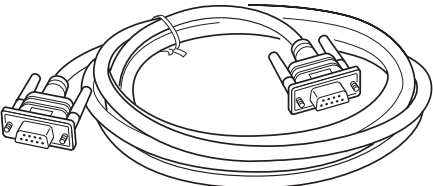
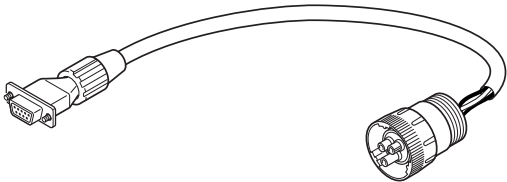
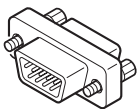
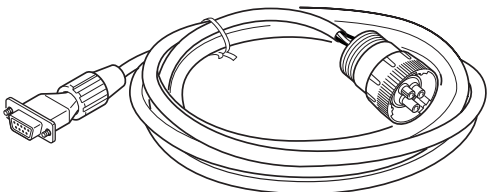
NO. 符号	Illustration 姿図	Internal Wiring 内部配線																											
①		<p>RS232C Female メス</p> <table border="1"> <tr><td>1</td><td></td><td>1</td></tr> <tr><td>2</td><td></td><td>2</td></tr> <tr><td>3</td><td></td><td>3</td></tr> <tr><td>4</td><td></td><td>4</td></tr> <tr><td>5</td><td></td><td>5</td></tr> <tr><td>6</td><td></td><td>6</td></tr> <tr><td>7</td><td></td><td>7</td></tr> <tr><td>8</td><td></td><td>8</td></tr> <tr><td>Frame</td><td></td><td>フレーム</td></tr> </table> <p>RS232C Female メス</p>	1		1	2		2	3		3	4		4	5		5	6		6	7		7	8		8	Frame		フレーム
1		1																											
2		2																											
3		3																											
4		4																											
5		5																											
6		6																											
7		7																											
8		8																											
Frame		フレーム																											
②		<p>Daikin made ダイキン製</p> <table border="1"> <tr><td>A</td><td>Red</td><td>1</td></tr> <tr><td>B</td><td>White</td><td>2</td></tr> <tr><td>C</td><td>Black</td><td>3</td></tr> <tr><td></td><td></td><td>4</td></tr> <tr><td></td><td></td><td>5</td></tr> <tr><td></td><td></td><td>6</td></tr> <tr><td></td><td></td><td>7</td></tr> <tr><td></td><td></td><td>8</td></tr> <tr><td></td><td></td><td>9</td></tr> </table> <p>RS232C Female メス</p>	A	Red	1	B	White	2	C	Black	3			4			5			6			7			8			9
A	Red	1																											
B	White	2																											
C	Black	3																											
		4																											
		5																											
		6																											
		7																											
		8																											
		9																											
③																													
④		<p>Daikin made ダイキン製</p> <table border="1"> <tr><td>A</td><td>Red 赤</td><td>1</td></tr> <tr><td>B</td><td>White 白</td><td>2</td></tr> <tr><td>C</td><td>Black 黒</td><td>3</td></tr> <tr><td></td><td></td><td>4</td></tr> <tr><td></td><td></td><td>5</td></tr> <tr><td></td><td></td><td>6</td></tr> <tr><td></td><td></td><td>7</td></tr> <tr><td></td><td></td><td>8</td></tr> <tr><td></td><td></td><td>フレーム</td></tr> </table> <p>RS232C Female メス</p>	A	Red 赤	1	B	White 白	2	C	Black 黒	3			4			5			6			7			8			フレーム
A	Red 赤	1																											
B	White 白	2																											
C	Black 黒	3																											
		4																											
		5																											
		6																											
		7																											
		8																											
		フレーム																											

1. DAIKIN OVERSEAS PARTS SUPPLY CENTER

JAPAN PARTS CENTER

DAIKIN INDUSTRIES LTD. Sakai Parts Center.
9 Ishizu-Nishi-machi, Sakai, Osaka 592-8332, Japan
Phone: 81 (72) 241-9103, Fax: 81 (72) 243-1290

ASIA PARTS CENTER

DAIKIN ASIA SERVICING PTE, LTD.
19 Loyang Way #02-21 Singapore 508724
Phone: (65) 546-8678, Fax: (65) 546-9727

EUROPEAN PARTS CENTER

DAIKIN EUROPE N.V.
Zandvoordestraat 300, B-8400 Oostende, Belgium
Phone: 32 (59) 558360, Fax: 32 (59) 558361

USA PARTS CENTER

DAIKIN U.S. CORPORATION
C/O SUMITOMO WAREHOUSE (USA) INC.
19301 Pacific Gateway Drive, Tarrance, CA90502, USA
Phone: 1 (310) 769-0105, Fax: 1 (310) 769-0304

AUSTRALIAN PARTS CENTER

DAIKIN AUSTRALIA PTY, LTD.
77-83 Alfred Road, Chipping Norton, N.S.W. 2170 Australia
Phone: 61 (2) 9755-3322, Fax: 61 (2) 9755-2016

NEW ZEALAND PARTS CENTER

P & O NEDLLOYD CONTAINER LTD.
Fergusson Container Terminal, Sunderland Street, Auckland, New Zealand
Phone: 64 (4) 494-9423, Fax: 64 (4) 494-9424

SHANGHAI PARTS CENTER

**DONGHWA CONTAINER
TRANSPORTATION SERVICE CO., LTD.**
2016, Yi Xian Road, Shanghai 200441,
People's Republic of China.
Phone: 86 (21) 5644-1717, Fax: 86 (21) 5644-0268

HONG KONG PARTS CENTER

DAIKIN AIRCONDITIONING (HONG KONG) LTD.
Room 801, Block B. Sea View Estate, Watson Road,
North Point, Hong Kong.
Phone: 852 (2570) 2786, Fax: 852 (2807) 2484

TAIWAN PARTS CENTER

HI-TECH ENGINEERING CO., LTD.
NO.585, SEC.3, TA-DUNG RD
HSI-CHIH, TAIPEI HSIEN, TAIWAN
Phone: 886(2)86487570, Fax: 886(2)86484283

SINGAPORE PARTS CENTER

EASTERN (1961) CO PTE LTD.
20 Tagore Lane Singapore 787478
Phone: 65 452-1950, Fax: 65 459-1790

DAIKIN INDUSTRIES, LTD.

Head Office: Umeda Center Bldg., 4-12, Nakazaki-Nishi 2-chome, Kita-ku Osaka, 530-8323 Japan
Tokyo Office: Tokyo Opera City Tower 12F, 3-20-2, Nishi-Shinjuku, Shinjuku-ku Tokyo 163-1412 Japan