

<https://daikin-p.ru>

DAIKIN



DAIKIN

Marine type

Container Refrigeration Unit

Service Manual · Parts List

Optional Functions

Model

LXE10D-A2

DAIKIN INDUSTRIES, LTD.

TR01-11

This manual describes only the items different from those of the standard machine.

For the items not described in this manual, refer to the following document.

- Service Guide, Services
- Service Manual (Operation)
- Parts List
- Operation Manual of Personal Computer Software
- Compressor Dismantling and Assembly Manual

Denomination of Model Name

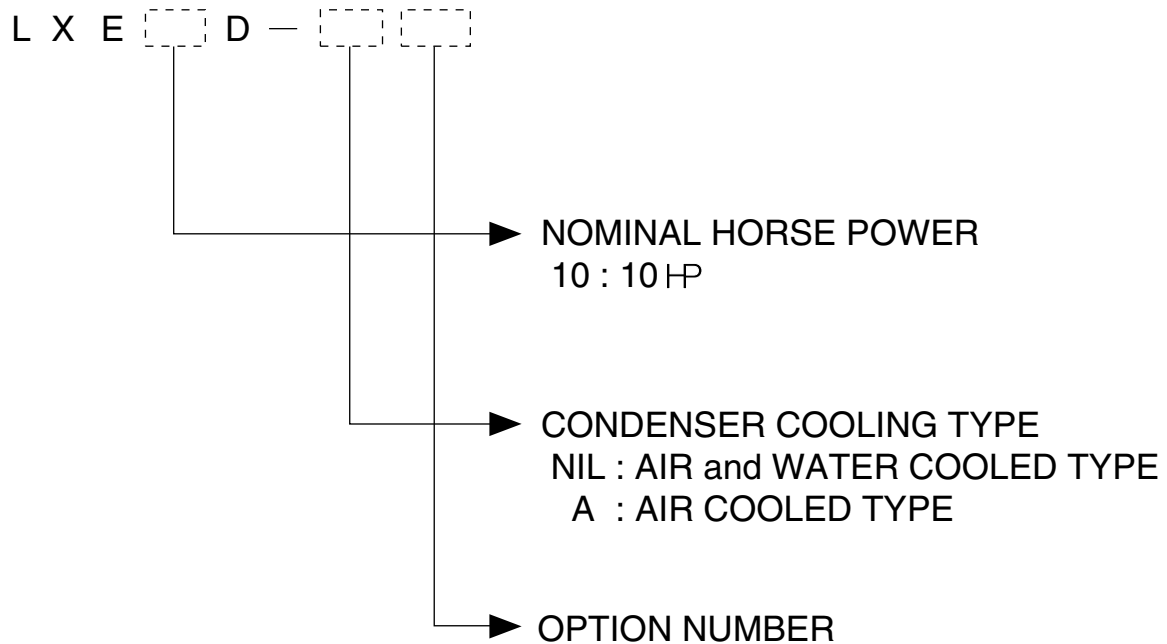

Note) "R" GIVEN AFTER OPTION NUMBER STANDS FOR "REVISION" AND IT IS GIVEN FOR THE UNIT WHICH IS SPECIALLY MODIFIED.

CONTENTS

Chapter for operation and service work3

1. Covered Model4

2. Schematic wiring diagram5

3. Stereoscopic wiring diagram6

Chapter for Parts List7

<https://daikin-p.ru>

Chapter for operation and service work

(The items which are different from that of the standard products only are described in this manual)

1. Covered Model

This Service manual describes only the items different from those of the standard machine regarding the features and operation of LXE10D-A2.

NO.	Item	Different points from service manual (Maintenance and Repair)
1	Recorder recording when the power supply is off	The pen is held at the indoor temperature of the time when the power supply is turned off. (The constant temperature continues recorded.)
2	Emergency coil cap (for electronic expansion valve)	It is provided on the rear side of the recorder box.
3	Wiring for modem	Provided with the connector and wiring for the modem of Sabro brand.

2. Schematic wiring diagram

<https://daikin-p.ru>

CONTAINER REFRIGERATION UNIT WIRING DIAGRAM

NOTES 1. POSITIONS OF VOLTAGE SELECTOR SWITCH (VS)
 2. MONITORING PLUG CONNECTED AS FOLLOW (FRONT VIEW) (RM)
 3. SCREW TERMINAL CONNECTOR TAB TERMINAL OPTIONAL PARTS

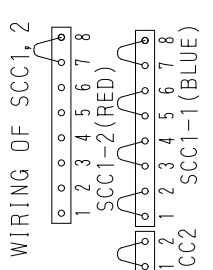
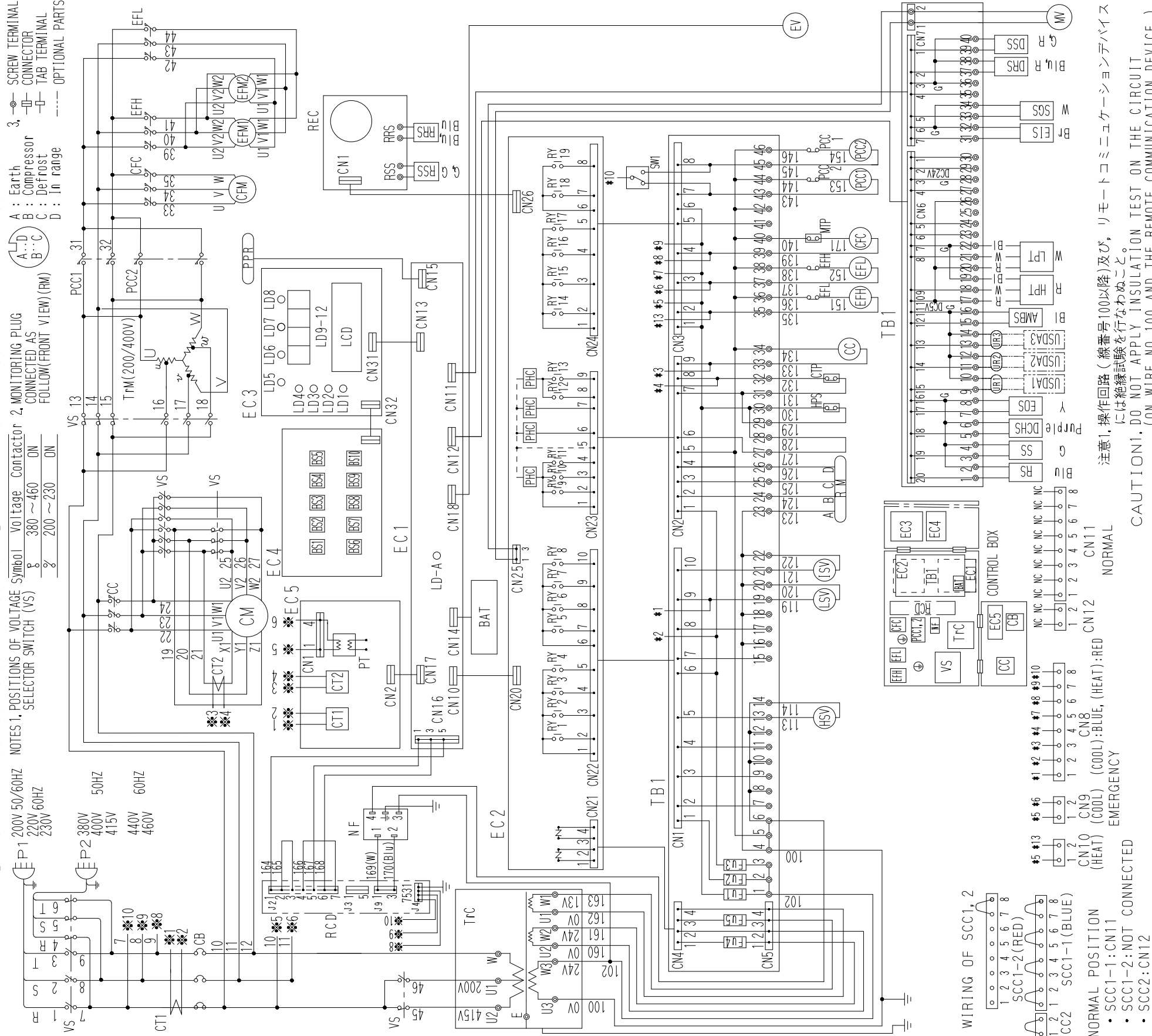

注意1. 操作回路(線番号100以降)及び、リモートコミュニケーションデバイスには絶縁試験を行なわぬこと。
 CAUTION1. DO NOT APPLY INSULATION TEST ON THE CIRCUIT (ON WIRE NO. 100 AND THE REMOTE COMMUNICATION DEVICE.)

Component	Terminal	Function
AMBS	AMBS	AMBIENT TEMP. SENSOR
BAT	BAT	BATTERY
BS1-10	BS1	PUSH BUTTON SWITCH
CB	CB	CIRCUIT BREAKER(50A)
CC	CC	COMPRESSOR CONTACTOR
CFC	CFC	CONDENSER FAN CONTACTOR
CFM	CFM	CONDENSER FAN MOTOR
CM	CM	COMPRESSOR MOTOR
CT1, 2	CT1, 2	CURRENT TRANSFORMER
CTP	CTP	COMPRESSOR THERMAL PROTECTOR
DCHS	DCHS	COMPRESSOR DISCHARGE SENSOR
DRS	DRS	DATA RECORDER RETURN AIR SENSOR
DSS	DSS	DATA RECORDER SUPPLY AIR SENSOR
EC1	EC1	CPU BOARD (DECOS)
EC2	EC2	I/O BOARD (DECOS)
EC3	EC3	DISPLAY BOARD (DECOS)
EC4	EC4	SHEET KEY (DECOS)
EC5	EC5	PRINTED CIRCUIT BOARD (PT, CT)
EFH	EFH	HIGH SPEED EVAPORATOR FAN CONTACTOR
EFL	EFL	LOW SPEED EVAPORATOR FAN CONTACTOR
EFM1, 2	EFM1, 2	EVAPORATOR FAN MOTOR
EIS	EIS	EVAPORATOR INLET SENSOR
EOS	EOS	EVAPORATOR OUTLET SENSOR
EV	EV	ELECTRONIC EXPANSION VALVE
Fu1-5	Fu1-5	FUSE(250V, 10A)
HPS	HPS	CONDENSER FAN CONTACTOR
HPT	HPT	CONDENSER FAN MOTOR
HSV	HSV	COMPRESSOR MOTOR
ISV	ISV	INJECTION SOLENOID VALVE
LCD	LCD	COMPRESSOR THERMAL PROTECTOR
LD-A	LD-A	COMPRESSOR DISCHARGE SENSOR
LD1	LD1	DATA RECORDER RETURN AIR SENSOR
LD2	LD2	DATA RECORDER SUPPLY AIR SENSOR
LD3	LD3	CPU BOARD (DECOS)
LD4	LD4	I/O BOARD (DECOS)
LD5	LD5	DISPLAY BOARD (DECOS)
LD6	LD6	SHEET KEY (DECOS)
LD7	LD7	PRINTED CIRCUIT BOARD (PT, CT)
LD8	LD8	HIGH SPEED EVAPORATOR FAN CONTACTOR
LD9-12	LD9-12	LOW SPEED EVAPORATOR FAN CONTACTOR
LSV	LSV	EVAPORATOR FAN MOTOR
LPT	LPT	EVAPORATOR INLET SENSOR
MV	MV	EVAPORATOR OUTLET SENSOR
MTP	MTP	ELECTRONIC EXPANSION VALVE
NF	NF	FUSE(250V, 10A)
PI, 2	PI, 2	CONDENSER FAN CONTACTOR
PCC1, 2	PCC1, 2	CONDENSER FAN MOTOR
PHC	PHC	COMPRESSOR MOTOR
PHC1	PHC1	INJECTION SOLENOID VALVE
PHC2	PHC2	COMPRESSOR THERMAL PROTECTOR
PHC3	PHC3	COMPRESSOR DISCHARGE SENSOR
PPR	PPR	DATA RECORDER RETURN AIR SENSOR
PT	PT	DATA RECORDER SUPPLY AIR SENSOR
REC	REC	CPU BOARD (DECOS)
RM	RM	I/O BOARD (DECOS)
RSS	RSS	DISPLAY BOARD (DECOS)
RSS1-1, 2	RSS1-1, 2	SHEET KEY (DECOS)
RSS2	RSS2	PRINTED CIRCUIT BOARD (PT, CT)
RY1-19	RY1-19	HIGH SPEED EVAPORATOR FAN CONTACTOR
SCC1-1, 2	SCC1-1, 2	LOW SPEED EVAPORATOR FAN CONTACTOR
SCC2	SCC2	PRINTED CIRCUIT BOARD (PT, CT)
SS	SS	HIGH SPEED EVAPORATOR FAN CONTACTOR
SS1	SS1	LOW SPEED EVAPORATOR FAN CONTACTOR
SS2	SS2	PRINTED CIRCUIT BOARD (PT, CT)
SS3	SS3	HIGH SPEED EVAPORATOR FAN CONTACTOR
SS4	SS4	LOW SPEED EVAPORATOR FAN CONTACTOR
SS5	SS5	PRINTED CIRCUIT BOARD (PT, CT)
SS6	SS6	HIGH SPEED EVAPORATOR FAN CONTACTOR
SS7	SS7	LOW SPEED EVAPORATOR FAN CONTACTOR
SS8	SS8	PRINTED CIRCUIT BOARD (PT, CT)
SS9	SS9	HIGH SPEED EVAPORATOR FAN CONTACTOR
SS10	SS10	LOW SPEED EVAPORATOR FAN CONTACTOR
SS11	SS11	PRINTED CIRCUIT BOARD (PT, CT)
SS12	SS12	HIGH SPEED EVAPORATOR FAN CONTACTOR
SS13	SS13	LOW SPEED EVAPORATOR FAN CONTACTOR
SS14	SS14	PRINTED CIRCUIT BOARD (PT, CT)
SS15	SS15	HIGH SPEED EVAPORATOR FAN CONTACTOR
SS16	SS16	LOW SPEED EVAPORATOR FAN CONTACTOR
SS17	SS17	PRINTED CIRCUIT BOARD (PT, CT)
SS18	SS18	HIGH SPEED EVAPORATOR FAN CONTACTOR
SS19	SS19	LOW SPEED EVAPORATOR FAN CONTACTOR
SS20	SS20	PRINTED CIRCUIT BOARD (PT, CT)
SS21	SS21	HIGH SPEED EVAPORATOR FAN CONTACTOR
SS22	SS22	LOW SPEED EVAPORATOR FAN CONTACTOR
SS23	SS23	PRINTED CIRCUIT BOARD (PT, CT)
SS24	SS24	HIGH SPEED EVAPORATOR FAN CONTACTOR
SS25	SS25	LOW SPEED EVAPORATOR FAN CONTACTOR
SS26	SS26	PRINTED CIRCUIT BOARD (PT, CT)
SS27	SS27	HIGH SPEED EVAPORATOR FAN CONTACTOR
SS28	SS28	LOW SPEED EVAPORATOR FAN CONTACTOR
SS29	SS29	PRINTED CIRCUIT BOARD (PT, CT)
SS30	SS30	HIGH SPEED EVAPORATOR FAN CONTACTOR
SS31	SS31	LOW SPEED EVAPORATOR FAN CONTACTOR
SS32	SS32	PRINTED CIRCUIT BOARD (PT, CT)
SS33	SS33	HIGH SPEED EVAPORATOR FAN CONTACTOR
SS34	SS34	LOW SPEED EVAPORATOR FAN CONTACTOR
SS35	SS35	PRINTED CIRCUIT BOARD (PT, CT)
SS36	SS36	HIGH SPEED EVAPORATOR FAN CONTACTOR
SS37	SS37	LOW SPEED EVAPORATOR FAN CONTACTOR
SS38	SS38	PRINTED CIRCUIT BOARD (PT, CT)
SS39	SS39	HIGH SPEED EVAPORATOR FAN CONTACTOR
SS40	SS40	LOW SPEED EVAPORATOR FAN CONTACTOR

LXE10D-A2, A7

2D006816-1C

3. Stereoscopic wiring diagram

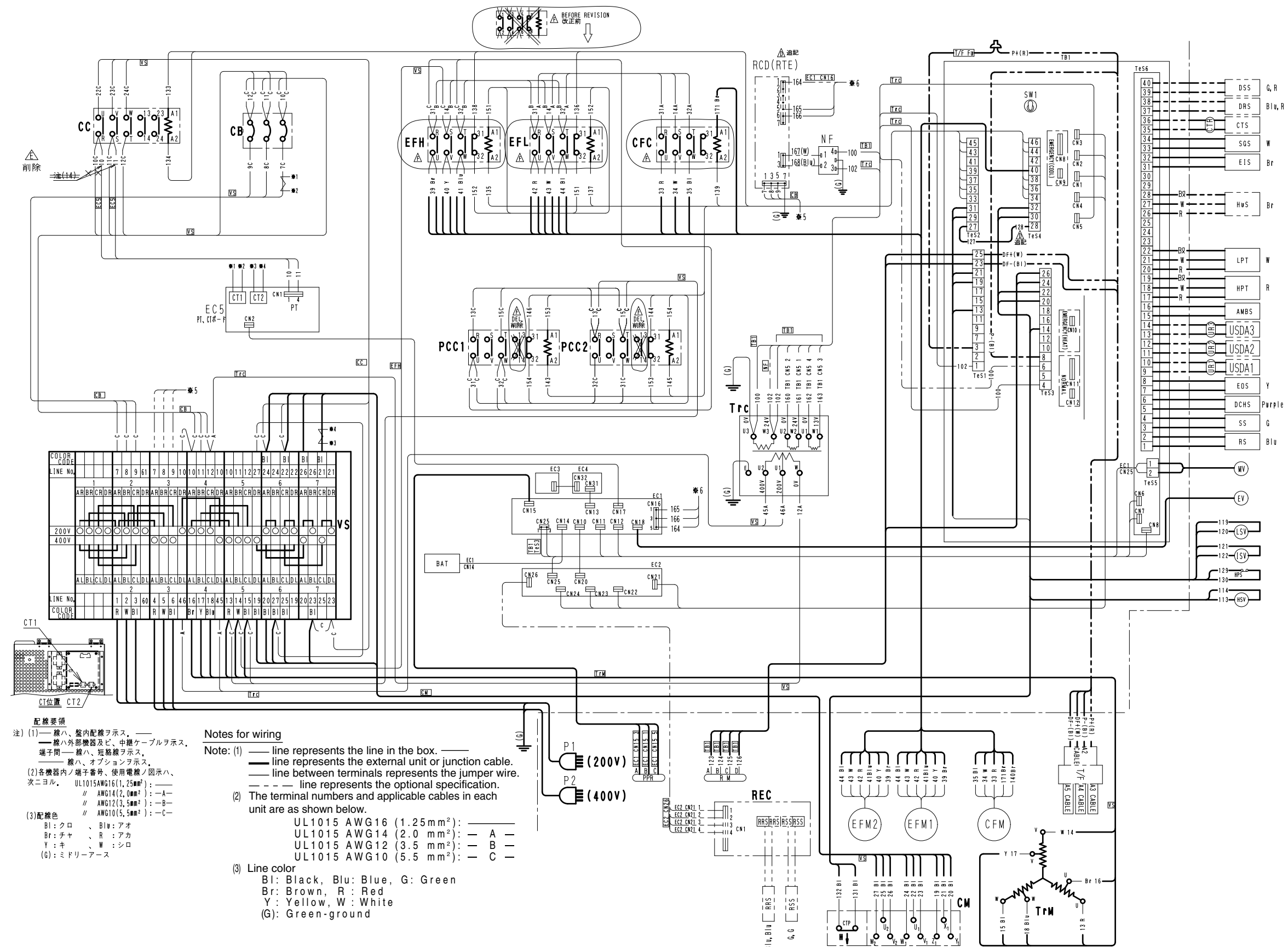

Chapter for Parts List

(The parts which are different from that of the standard products only are described in this parts list)

The parts which are different from that of the standard model only are described in this manual. Regarding the items which are not described in this manual, refer to Parts List (TR97-11C) as well.

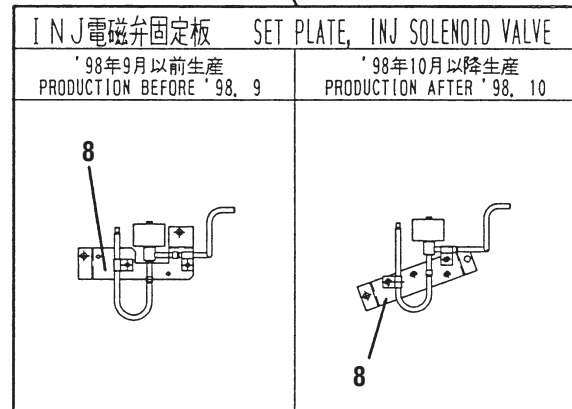
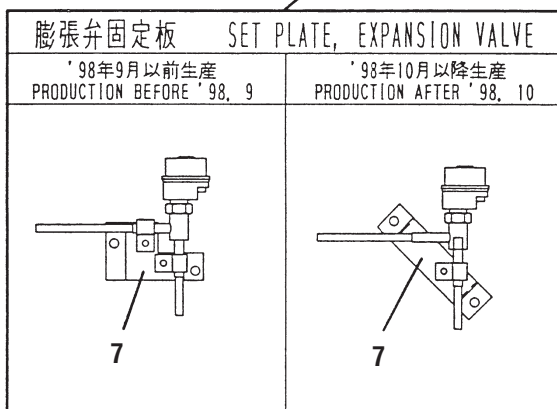
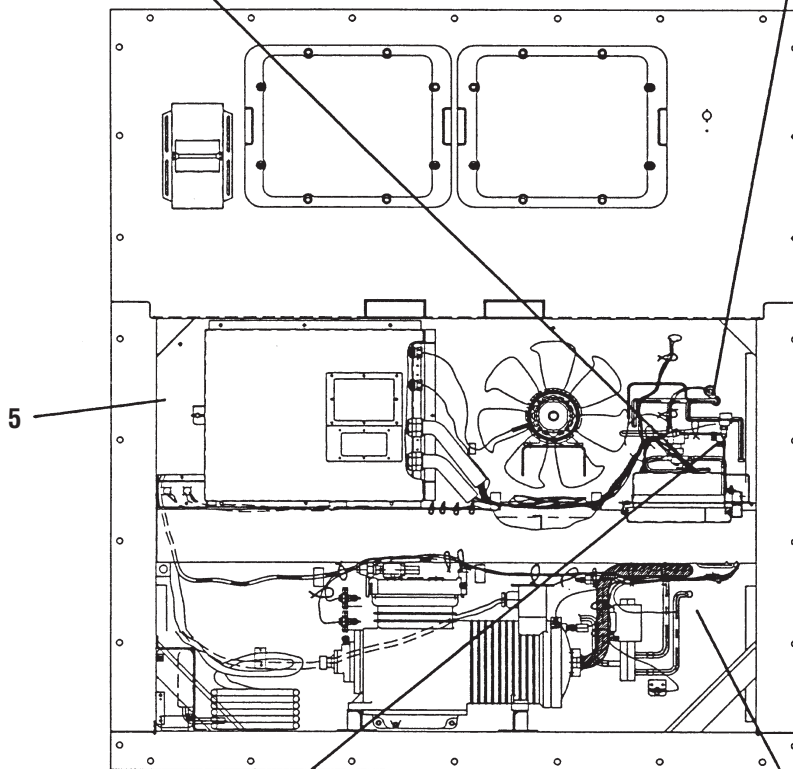
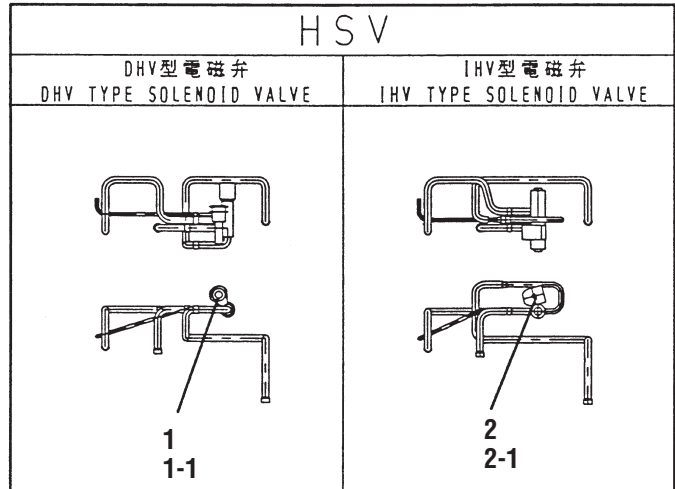
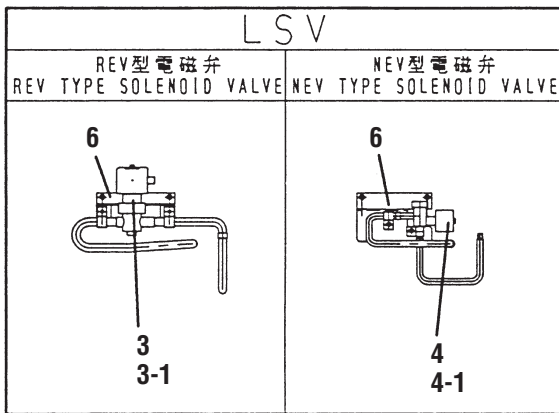

Parts related with the unit (outside) 1
庫外関連部品 1

a:'98年12月以前/Production before '98.12,b:'99年1月以降/Production after '99.1

NO. 符号	PARTS NO. 部品番号	PARTS NAME	部品名称	DWG. NO. 図面番号	TYPE SPECIFICATION 形式仕様	QTY/UNIT 1台当りの所要数		REMARKS 備考
						a	b	
1	0598622	Three way solenoid valve (HSV)	三方電磁弁 (H S V)	3PA11792-4	DHV-804DXF	1		BODY+COIL
1-1	0598639	Coil, three way solenoid valve	三方電磁弁コイル	3PA11792-4-KA		1		COIL ONLY
2	1074516	INV type solenoid valve body	I H V型電磁弁弁体	3SA52051-1	IHV0201, HSV		1	BODY ONLY
2-1	0955287	Solenoid valve coil	電磁弁コイル	3P010453-1			1	COIL ONLY
3	0598684	Refrigerant solenoid valve (LSV)	冷媒用電磁弁 (L S V)	3PA43018-3	REV-1004DXFQ44	1		BODY+COIL
3-1	0598691	Coil, solenoid valve	電磁弁コイル	3PA43018-3-KA		1		COIL ONLY
4	0944566	NEV type solenoid valve body	N E V型電磁弁本体	R3305118-1	NEV-803DXF		1	BODY ONLY
4-1	0955287	Solenoid valve coil	電磁弁コイル	3P010453-1			1	COIL ONLY
5		Control, box front plate	C, B O X前板 (左)	2P023471-1		1		
5		Control, box front plate	C, B O X前板 (左)	2P026254-1			1	

c:'98年9月以前/Production before '98.9,d:'99年1月以降/Production after '99.1

NO. 符号	PARTS NO. 部品番号	PARTS NAME	部品名称	DWG. NO. 図面番号	TYPE SPECIFICATION 形式仕様	QTY/UNIT 1台当りの所要数		REMARKS 備考
						c	d	
6		Set plate, solenoid valve	液電磁弁固定板	4P007021-1		1		
6		Set plate liquid solenoid valve	液電磁弁固定板	4P028110-1			1	

e:'98年10月から'98年12月生産/Production from '98.10 to '98.12

NO. 符号	PARTS NO. 部品番号	PARTS NAME	部品名称	DWG. NO. 図面番号	TYPE SPECIFICATION 形式仕様	QTY/UNIT 1台当りの所要数	REMARKS 備考
						e	
6		Set plate liquid solenoid valve	液電磁弁固定板	4P007021-2		1	

• When ordering the parts whose No. are not shown in the PARTS NO. column, be sure to describe DWG. NO..

• 部品番号欄が空白になっている部品は、図面番号で、指示願います。
(TR01-11)

Parts related with the unit (outside) 1
庫外関連部品 1

f:'98年 9 月以前 / Production before '98.9.g:'98年10月以降 / Production after '98.10

NO. 符号	PARTS NO. 部品番号	PARTS NAME	部 品 名 称	DWG. NO. 図面番号	TYPE 形式	SPECIFICATION 仕 様	QTY/UNIT 1台当りの所要数		REMARKS 備 考
							f	g	
7		Set plate, solenoid valve	膨張弁固定板	4P011328-1			1		
7		Set plate, expansion valve	膨張弁固定板	4P011328-2				1	
8		Set plate, INJ expansion valve	I N J 電磁弁固定板	4P000395-1			1		
8		Set plate, INJ solenoid valve	I N J 電磁弁固定板	4P000395-2				1	

• When ordering the parts whose No. are not shown in the PARTS NO. column, be sure to describe DWG. NO..

• 部品番号欄が空白になっている部品は、図面番号で、指示願います。
(TR01-11)

Parts related with the unit (outside) 1

庫外関連部品 1

NO. 符号	PARTS NO. 部品番号	PARTS NAME 部 品 名 称	DWG. NO. 図面番号	TYPE 形 式	SPECIFICATION 仕 様	QTY/UNIT 1台当りの所要数	REMARKS 備 考

• When ordering the parts whose No. are not shown in the PARTS NO. column, be sure to describe DWG. NO..

• 部品番号欄が空白になっている部品は、図面番号で、指示願います。
(TR01-11)

'98年12月生産以前 / Production before '98.12

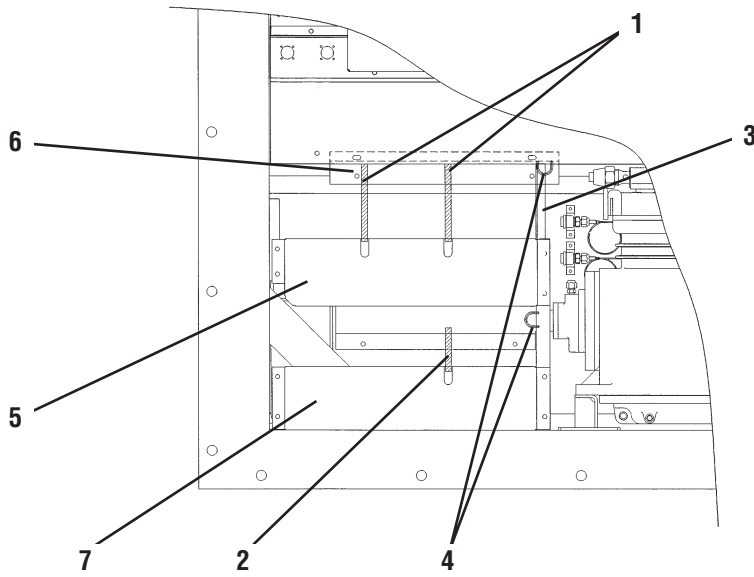

'99年1月生産以降 / Production after '99.1

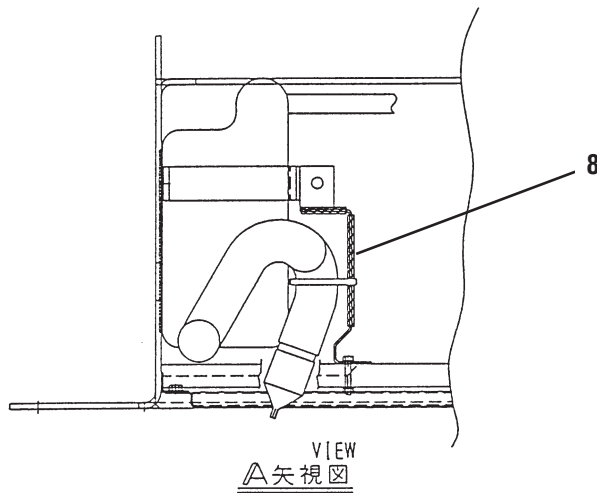
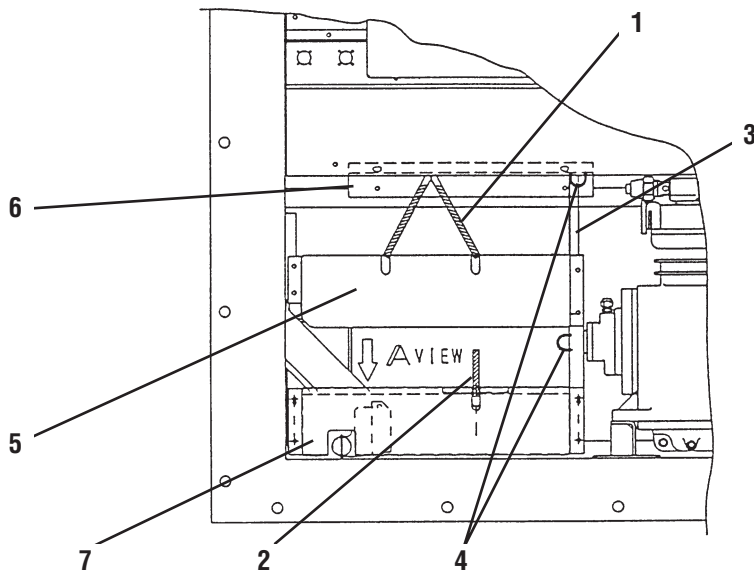

Parts related with the unit (outside) 2

庫外関連部品 2

a:'98年12月以前/Production before '98.12,b:'99年1月以降/Production after '99.1

NO. 符号	PARTS NO. 部品番号	PARTS NAME	部 品 名 称	DWG. NO. 図面番号	TYPE 形 式	SPECIFICATION 仕 様	QTY/UNIT 1台当りの所要数		REMARKS 備 考
							a	b	
1		Cable stopper	電源ケーブルストッパー (1)	4P016078-1			2		
1		Cable stopper (1)	電源ケーブルストッパー (1)	4P026824-1				1	
2		Cable stopper	電源ケーブルストッパー (2)	4P016078-2			1	1	
3		Stay	ステー (ケーブル固定バンド)	4P017378-1			1	1	
4	1263905	U bolt	Uボルト	4P016803-1			2	2	
5	1238497	Cable front plate (Dual, upper)	ケーブル前板 (デュアル、上)	3P001890-1			1	1	
6	1263912	Reinforce plate for cable	ケーブル収納部保護板	3P015323-1			1	1	
7		Cable front plate (Dual, lower)	ケーブル前板 (デュアル、下)	3P001894-1				1	
8		Guide plate	ガイド板	4P027576-1					

• When ordering the parts whose No. are not shown in the PARTS NO. column, be sure to describe DWG. NO..

• 部品番号欄が空白になっている部品は、図面番号で、指示願います。
(TR01-11)

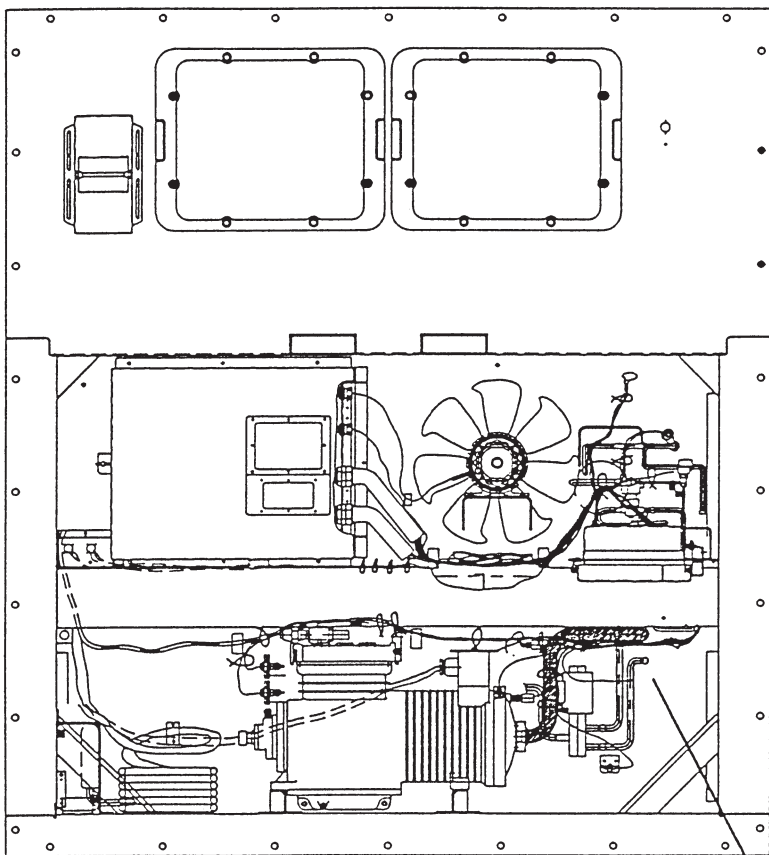

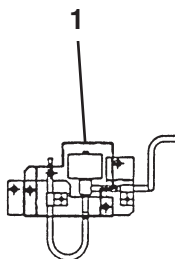
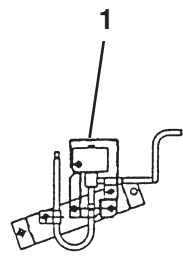
'98年12月以前生産 PRODUCTION BEFORE '98. 12	'99年1月以降生産 PRODUCTION AFTER '99. 1
	

Parts related with the unit (outside) 3

庫外関連部品 3

a:'98年12月以前/Production before '98.12,b:'99年1月以降/Production after '99.1

NO. 符号	PARTS NO. 部品番号	PARTS NAME 部品名称	DWG. NO. 図面番号	TYPE 形式	SPECIFICATION 仕様	QTY/UNIT 1台当りの所要数		REMARKS 備考
						a	b	
1		Protection plate (INJ)	I N J 弁保護板	4P015328-1		1		
1	1135985	Protection plate (INJ)	I N J 弁配管保護板	4P028673-1			1	

• When ordering the parts whose No. are not shown in the PARTS NO. column, be sure to describe DWG. NO..

• 部品番号欄が空白になっている部品は、図面番号で、指示願います。
(TR01-11)

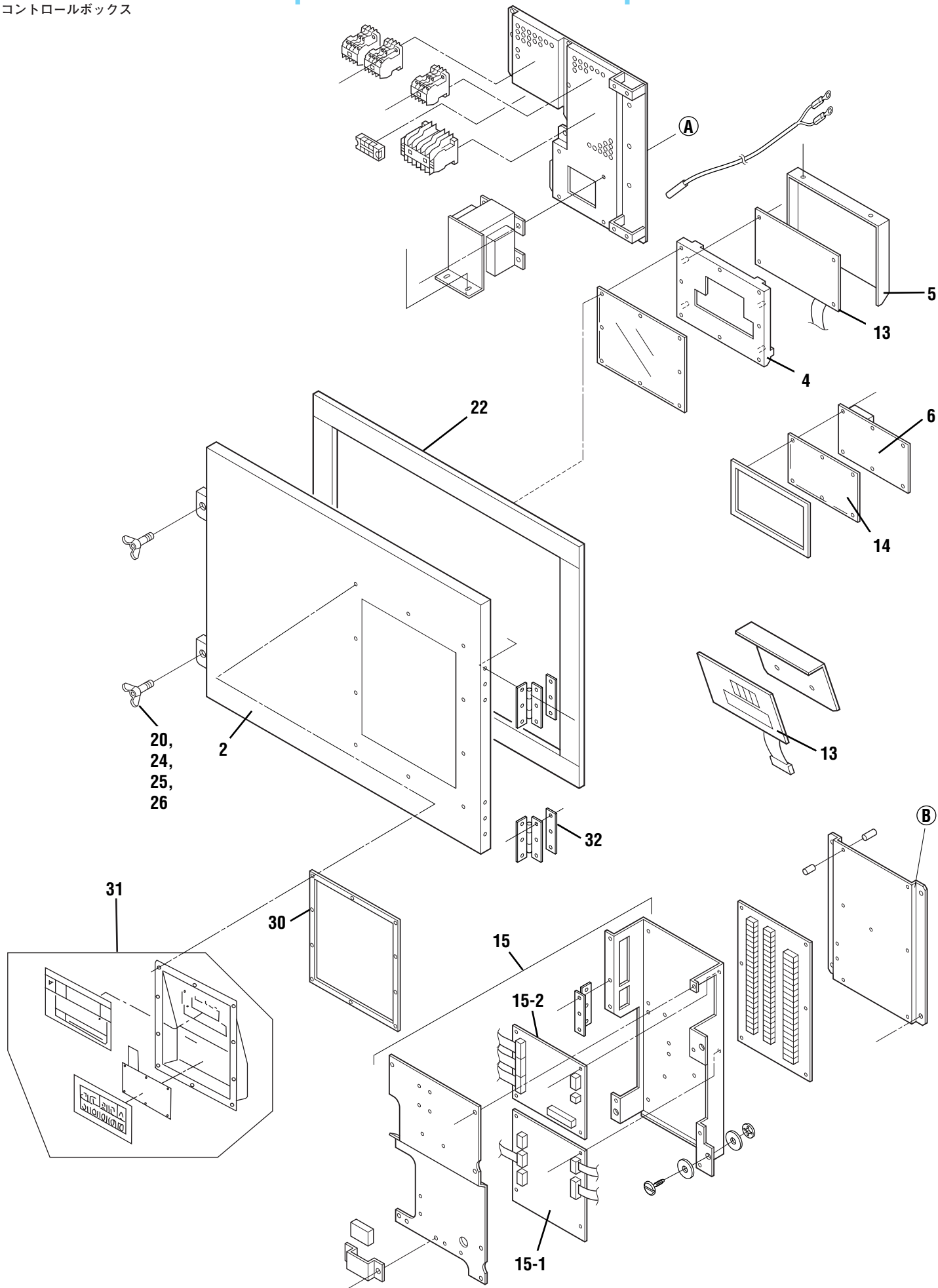

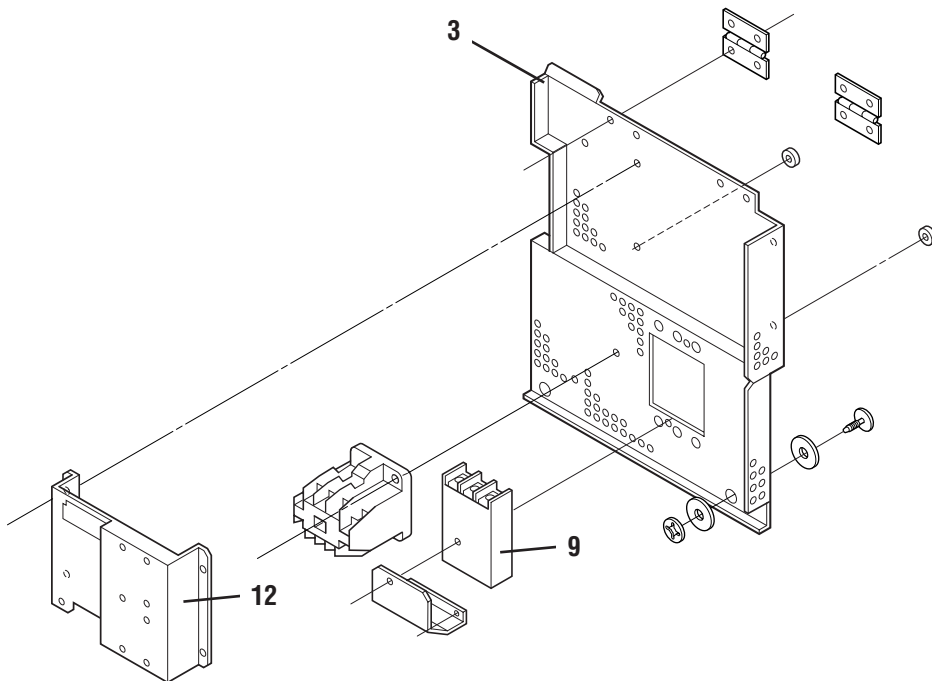
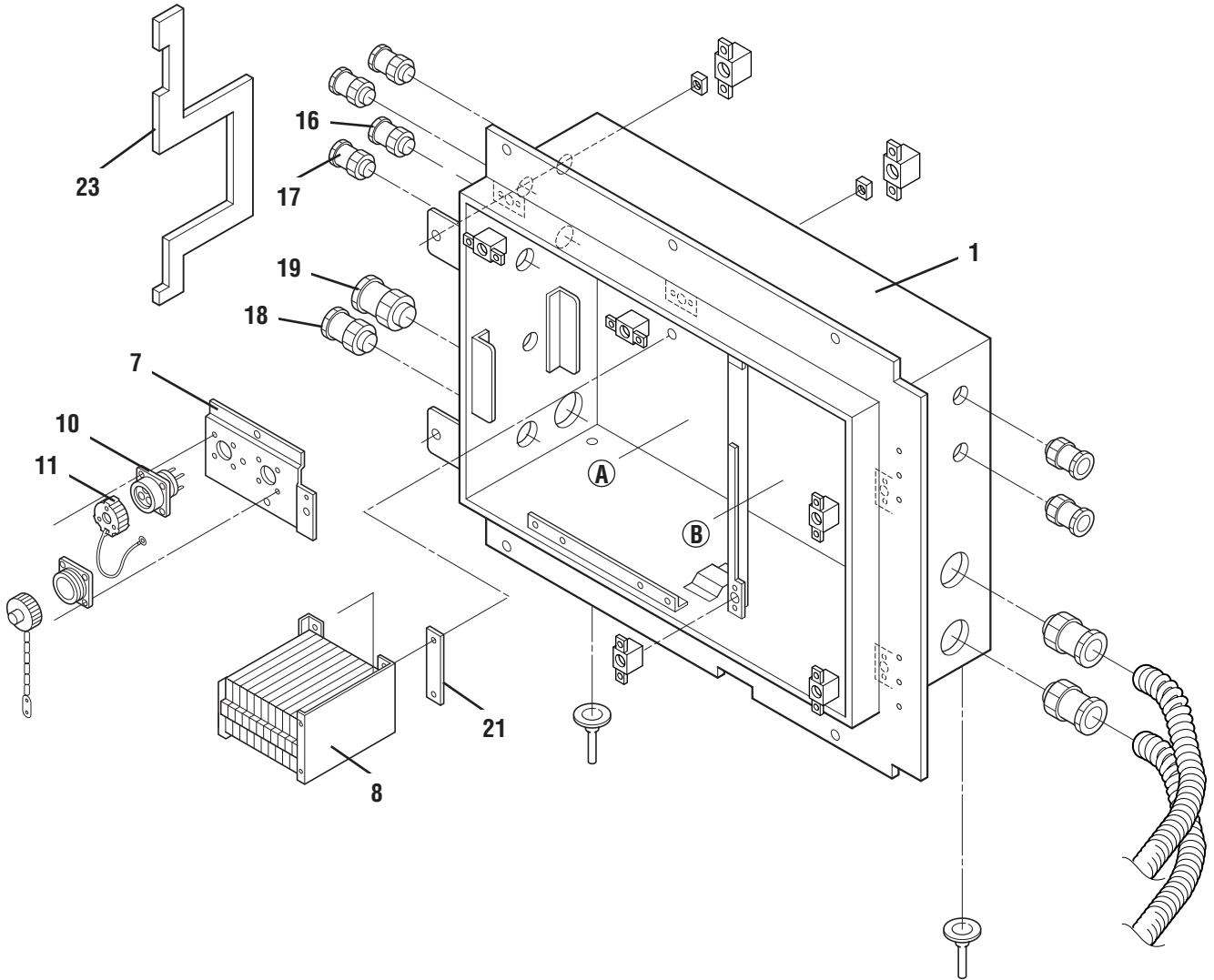

Control box

コントロールボックス

a:'98年12月以前/Production before '98.12,b:'99年1月以降/Production after '99.1

NO. 符号	PARTS NO. 部品番号	PARTS NAME 部品名称	DWG. NO. 図面番号	TYPE 形式	SPECIFICATION 仕様	QTY/UNIT 1台当りの所要数		REMARKS 備考
						a	b	
1		C.box welding ass'y	C. BOX溶接組立品	2P003754-1		1		
1		C.box welding ass'y	C. BOX溶接組立品	2P020981-1			1	
2	0991555	Control box cover welding ass'y	コントロールボックス蓋溶接組立品	3P003505-1		1		
2	1178836	C.box cover	コントロールボックス蓋	3P031480-1			1	
3		Set plate, control devices (2)	機器取付板 (2)	2P010019-1		1		
3		Blind plate (2)	機器取付板 (2)	2P021378-1			1	
4	1142154	Plate, label	銘板張付用板	3P003753-1		1		
5	1140165	Cover, display board	表示基板用カバー	3P005734-1		1		
6		Fixing plate,sheet key	取付板 (シートキー)	4P00354-1		1		
7		Fixing plate, PC port	パソコンレセプタクル固定板	4P009422-1		1		
7		PC port fixing plate	パソコンポート固定板	4P020837-1			1	
8	634017	Cam switch (VS)	カムスイッチ (VS)	R3421041-3	7P-3CL	1	1	
9	0344971	Circuit breaker (CB)	ノーフェューズブレーカ (CB)	3PA37567-1	EA53B/50 50A	1	1	
10	0991531	PC port connector	パソコンポートコネクタ	3P010803-1		1	1	
11	1270011	Personal computer port cover	パソコンポートカバー	3P010805-1		1	1	
12	0980788	PT/CT board	P T / C T ボード	2P010906-1		1	1	
13	1010815	Display board	表示基板	2P010368-2	EC9755-2	1	1	
14	0954570	Membrane switch	シートキー	2P010363-1		1		
15	1075526	CPU & I/O board ass'y	C P U & I / O ボード組立品	3P015006-9		1	1	
15-1	1080270	CPU board	C P U ボード	2P010365-5		1	1	
15-2	0954594	I/O board	I / O ボード	2P010367-1		1	1	
16	0758657	Cable gland	電線グラウンド	3PA37599-7	SCL-18A ケーブルコネクタ	1	1	
17	0758633	Cable gland	電線グラウンド	3PA37599-8	SCL-18B ケーブルコネクタ	1	1	
18	0965556	Cable gland	電線グラウンド	3PA37599-9	SCL-22A ケーブルコネクタ	1	1	
19	0966294	Cable gland	電線グラウンド	3PA37599-12	SCL-30B ケーブルコネクタ	1	1	
20	1170065	Wing bolt, control box cover	蝶ボルト(コントロールボックス蓋)	4P010750-1		2	1	
21	833012	Patch plate nut	当板ナット	R4718017-1		1	1	

● When ordering the parts whose No. are not shown in the PARTS NO. column, be sure to describe DWG. NO..

● 部品番号欄が空白になっている部品は、図面番号で、指示願います。

(TR01-11)

Control box
コントロールボックス

a:'98年12月以前/Production before '98.12,b:'99年1月以降/Production after '99.1

NO. 符号	PARTS NO. 部品番号	PARTS NAME	部品名称	DWG. NO. 図面番号	TYPE 形式	SPECIFICATION 仕様	QTY/UNIT 1台当りの所要数		REMARKS 備考
							a	b	
22		Rubber gasket	パッキン (C. BOX蓋)	4P003732-2			1		
22	1136469	Rubber gasket	パッキン (C. BOX蓋)	4P003732-1				1	
23		Packing (C.box front plate)	パッキン (C. BOX前板)	4P007341-1			1	1	
24	844022	Plain washer	平座金	4SK07005-12			2	1	
25	1136438	Insulation sheet	絶縁シート (C. BOX蓋)	4P016059-1			2	1	
26	1136445	Retaining ring	E形止メ輪	4P016093-1			2	1	
30		Membrane switch	シートキー	3P035564-1				1	
31	1128949	Packing	パッキン (樹脂パネル)	3P030317-1				1	
32	1238721	Plate nut	当板ナット	4P010116-1	M4		1		
32	1270035	Plate nut	プレートナット	4P010116-2	M5			1	

a:'98年6月以前/Production before '98.6,b:'98年7月以降/Production after '98.7

NO. 符号	PARTS NO. 部品番号	PARTS NAME	部品名称	DWG. NO. 図面番号	TYPE 形式	SPECIFICATION 仕様	QTY/UNIT 1台当りの所要数		REMARKS 備考
							a	b	
32	1267736	Connector for MODEM	モデム用コネクタ	3P012038-3	BLA3			1	FOR SABROE
33	0954640	Noise filter	ノイズフィルタ	2PA51273-1	ZAC2206-11			1	
34	1267750	Connector for MODEM	モデム用コネクタ	3P012038-7	BLA7			1	FOR SABROE
36	1267743	Connector for MODEM	モデム用コネクタ	3P010371-7	GMSTB2			1	FOR SABROE

• When ordering the parts whose No. are not shown in the PARTS NO. column, be sure to describe DWG. NO..

• 部品番号欄が空白になっている部品は、図面番号で、指示願います。
(TR01-11)

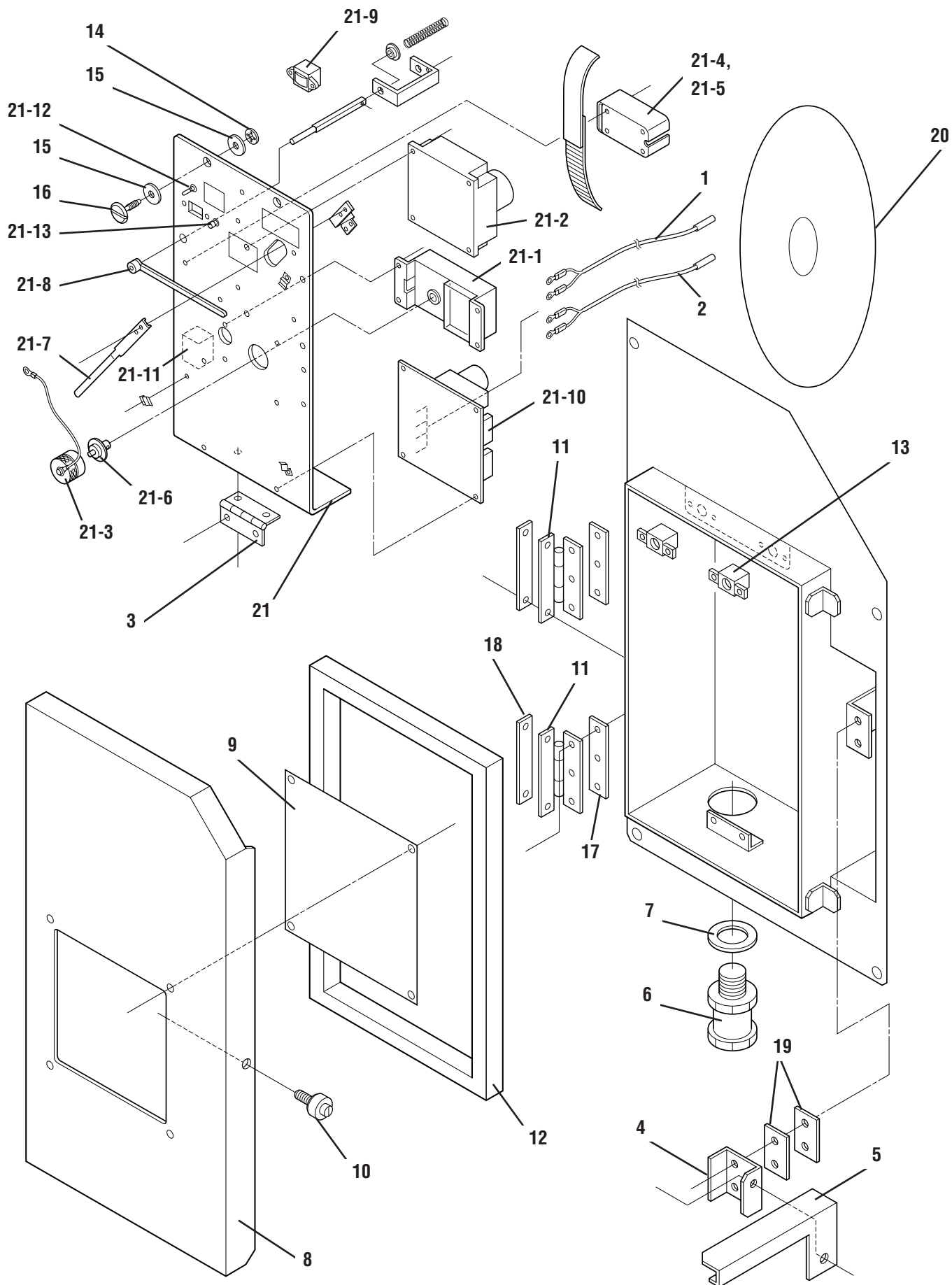

Recorder box

レコーダーボックス

a:'98年12月以前/Production before '98.12,b:'99年1月以降/Production after '99.1

NO. 符号	PARTS NO. 部品番号	PARTS NAME	部 品 名 称	DWG. NO. 図面番号	TYPE 形 式	SPECIFICATION 仕 様	QTY/UNIT 1台当りの所要数		REMARKS 備 考
							a	b	
1	0798307	Sensor (RSS)	センサー (RSS)	3PA61769-4	ST9503-4 (Green, Green)		1	1	
2	0798282	Sensor (RRS)	センサー (RRS)	3PA61769-2	ST9503-2 (Blue, Blue)		1	1	
3	351229	Hinge	平蝶番	R4717632-1			1	1	
4	1273445	Fixing plate, quick lock lever	ワンタッチ金具取付板	4P006369-1			1	1	
5	1273438	Quick lock lever	ワンタッチ金具	4P006358-1			1	1	
6	0966294	Cable gland	電線グラウンド	3PA37599-12	SCL-30B		1		
6	0773771	Cable gland	電線グラウンド	3PA37599-10	SCL-22B			1	
7	1270042	Rubber bush	ゴムブッシュ	4P006438-1			1		
7	1267844	Grand rubber bush	グラウンドゴムブッシュ	4P032156-1				1	
8	0991562	Cover (recorder)	蓋 (レコーダ)	3P005880-1			1	1	
9	1183511	Access window	点検窓	4P005883-1			1	1	
10	0907093	Roller, quick lock lever	ワンタッチ金具用ローラ	4PA51277-1			1	1	
11	351228	Hinge, cover	蓋締付蝶番	R4718767-1			2	2	
12	1211175	Packing (cover)	パッキン (蓋)	4P006431-1			1	1	
13	860015	Universal nut	自在ナット	R4713188-1			2	2	
14	840002	Drop out prevention washer	脱落防止座金	R4718607-6			2	2	
15	860005	Washer, speed bolt	スピードボルト用座金	R4713334			4	4	
16	860011	Speed bolt	スピードボルト	R4714824-1			2	2	
17	874014	Patch plate nut	当板ナット	R3715992-33			2	2	
18	847011	Patch plate nut	当板ナット	R3715992-32			2	2	
19	0907101	Spacer	スペーサ	4PA51278-1			2	2	
20	0581213	Recording chart	記録紙	3PA43798-1			5	5	

• When ordering the parts whose No. are not shown in the PARTS NO. column, be sure to describe DWG. NO..

• 部品番号欄が空白になっている部品は、図面番号で、指示願います。
(TR01-11)

Recorder
レコーダ

a:'98年5月以前/Production before '98.5,b:'98年6月以降/Production after '98.6

NO. 符号	PARTS NO. 部品番号	PARTS NAME 部品名称	DWG. NO. 図面番号	TYPE 形式	SPECIFICATION 仕様	QTY/UNIT 1台当りの所要数		REMARKS 備考
						a	b	
21	0980764	Electronic temperature recorder	電子式温度記録計	2P010361-2	DER9601	1		
21	1021985	Electronic temperature recorder	電子式レコーダ	2P021722-6	DER9601A		1	
21-1	0143495	Quartz motor	クォーツ時計	3PA20194-2		1	1	
21-2	0037336	Servo unit ass'y	サーボ組立品	3PA20195-1		1	1	
21-3	0037855	Chart stopper ass'y	チャート押さえ組立	4PA20211-1	A5052BP	1	1	
21-4		Dry battery	乾電池		SUM2(JIS C8501)IEC/R14	1	1	市販品PURCHASE LOCALLY
21-5		Battery holder	電池ホルダー	2PA021722-9-Ti		1	1	
21-6		Chart shaft	チャート軸受け	2PA021722-9-SU		1	1	
21-7		Pen ass'y	ペン組立品	2PA021722-9-Ko		1	1	
21-8		Lever	レバー	2PA021722-9-Ma		1	1	
21-9		Battery meter	メータ	2PA021722-9-Na		1	1	
21-10		Printed circuit board	P板組立品	2PA021722-9-So		1	1	
21-11		Dry battery	乾電池		6LR61-9V	1	1	市販品PURCHASE LOCALLY
21-12		Toggle switch	トグルスイッチ	2PA021722-9-Ne		1	1	
21-13		Push button switch	押しボタンスイッチ	2PA021722-9-Ni		1	1	

• When ordering the parts whose No. are not shown in the PARTS NO. column, be sure to describe DWG. NO..

• 部品番号欄が空白になっている部品は、図面番号で、指示願います。
(TR01-11)

Recorder
レコーダ

NO. 符号	PARTS NO. 部品番号	PARTS NAME 部品名称	DWG. NO. 図面番号	TYPE 形式	SPECIFICATION 仕様	QTY/UNIT 1台当りの所要数		REMARKS 備考
						a	b	

• When ordering the parts whose No. are not shown in the PARTS NO. column, be sure to describe DWG. NO..

• 部品番号欄が空白になっている部品は、図面番号で、指示願います。
(TR01-11)

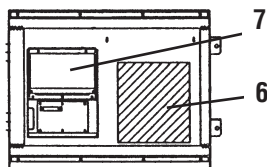

CONTROL BOX COVER

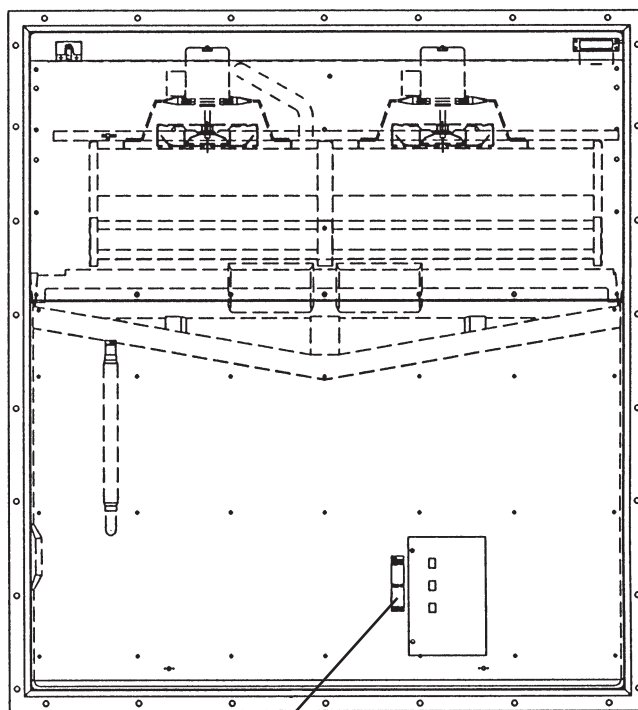
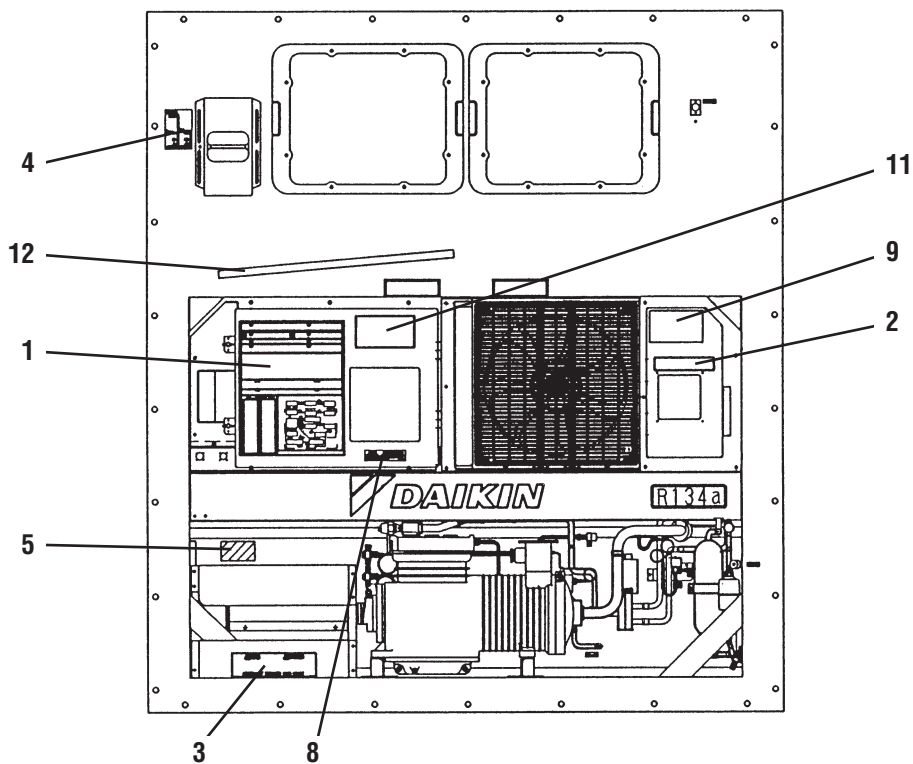

10

Parts related with the name plate

銘板関連部品

NO. 符号	PARTS NO. 部品番号	PARTS NAME	部品名称	DWG. NO. 図面番号	TYPE 形式	SPECIFICATION 仕様	QTY/UNIT 1台当りの所要数	REMARKS 備考
1	1181274	Name plate, caution	注意銘板	1P016112-1			1	
2		Name plate, recorder box	レコーダボックス銘板	3P016113-1			1	
3	1229037	Name plate, refrigerant /oil	冷媒・オイル注意銘板	3P016114-1			1	
4		Name plate, ventilator	換気口銘板	4P016228-1			1	
5		Name plate, unit performance	機械銘板	3P011037-1			1	
6	1269718	Name plate, wiring diagram	電気配線図銘板	2D006816-1			1	
7	1134829	Name plate, emergency	エマージェンシー銘板	3P016115-1			1	
8	1136508	Name plate, compressor start	圧縮機起動注意銘板	4P017393-1			1	
9		Emergency cap label	エマージェンシーキャップ銘板	3P018298-1			1	
10	1268171	Name plate, USDA	U S D A 銘板	3P009424-1			1	
11		Caution label, alarm	注意銘板 (アラーム)	3P027697-1			1	
12		Rain gutter	雨ドイ	4P039190-1			1	

• When ordering the parts whose No. are not shown in the PARTS NO. column, be sure to describe DWG. NO..

• 部品番号欄が空白になっている部品は、図面番号で、指示願います。
(TR01-11)

Parts related with the name plate

銘板関連部品

NO. 符号	PARTS NO. 部品番号	PARTS NAME	部品名称	DWG. NO. 図面番号	TYPE 形式	SPECIFICATION 仕様	QTY/UNIT 1台当りの所要数	REMARKS 備考

• When ordering the parts whose No. are not shown in the PARTS NO. column, be sure to describe DWG. NO..

• 部品番号欄が空白になっている部品は、図面番号で、指示願います。
(TR01-11)

Parts related with the name plate

銘板関連部品

NO. 符号	PARTS NO. 部品番号	PARTS NAME	部品名称	DWG. NO. 図面番号	TYPE 形式	SPECIFICATION 仕様	QTY/UNIT 1台当りの所要数	REMARKS 備考

• When ordering the parts whose No. are not shown in the PARTS NO. column, be sure to describe DWG. NO..

• 部品番号欄が空白になっている部品は、図面番号で、指示願います。(TR01-11)

