

**DAIKIN**



# ダイキン海上コンテナ冷凍装置

Marine type Container Refrigeration Unit

**サービスガイド・パーツリスト**

Service Manual · Parts List

**オプション機編・OPTIONAL FUNCTION**

## LXE10E-A24R

## LXE10E-A9R

Dual Unit Type

**ダイキン工業株式会社**  
**DAIKIN INDUSTRIES, LTD.**

TR05-03

## **Chapter for operation and service work**

(Only the special items for the dual unit are described in this manual.)

In this manual, only the special specifications of the dual unit are described.

For the items which are not described in this manual, refer to LXE10E-A service manual (TR01-09A) separately issued.

### **Modified Unit LXE10E-A24R、LXE10E-A9R**

"LXE10E-A24" and "LXE10E-A9" is described on the nameplate as the model name of this modified unit, to which "R" is not attached.

Please discriminate the applicable unit according to the Mfg. No. shown below.

LXE10E-A24R

Mfg. No. : 2400001 to 2400004

LXE10E-A9R

Mfg. No. : 2400001 to 2400012

This modification relates to the unit changeover at the emergency case (dual unit application.) .

Please refer to the following information for details.

## CONTENTS

### Caution for operation of control panel

· Caution .....	3
<b>1. DATA OF REFRIGERATION UNIT .....</b>	<b>4</b>
Main specifications .....	4
<b>2. Names of parts .....</b>	<b>5</b>
<b>3. Piping diagram .....</b>	<b>6</b>
<b>4. Operation .....</b>	<b>7</b>
4.1 Operation instructions .....	7
4.2 Unit selecting instructions .....	8
<b>5. Schematic wiring diagram .....</b>	<b>9</b>
<b>6. Stereoscopic wiring diagram .....</b>	<b>10</b>
<b>7. Operation of controller and recorder .....</b>	<b>12</b>

## Caution for operation of control panel

### CAUTION

**To turn ON/OFF the power supply of the unit, be sure to use the snap switch. (Don't use the switch of the sheet key.)**

Don't use the unit ON/OFF key on the sheet key of the ordinary control panel. (Don't remove the cover plate.)

●Panel display unit (surface)

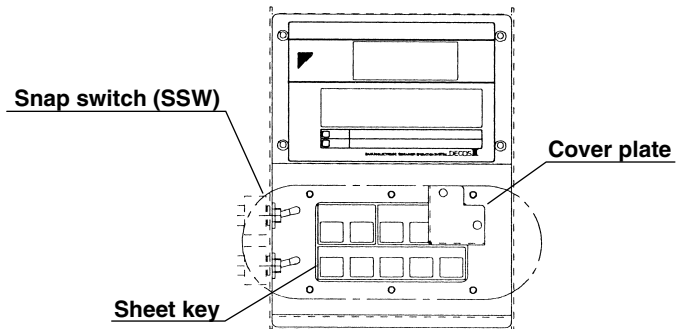

### CAUTION

**In the battery mode, don't turn off the unit ON/OFF setting. Be sure to keep it on.**

- When the setting is kept at OFF, the unit will not be started even if the snap switch is turned on.
- For detail explanation of the battery mode, refer to Item 11. Battery mode in Section 3.2.2 Operation method of display modes of the service manual of this document.

### CAUTION

**When the controller is replaced, be sure to change the ON/OFF setting of the unit of the battery mode from OFF to ON.**

※1 · After replacing the controller, set it in the following procedure.

- ① Remove the cover plate.
- ② Turn on the snap switch.
- ③ Press the unit ON/OFF of the sheet key. (Unit start)
- ④ Turn off the snap switch.
- ⑤ Return the cover plate into the original position.

## 1. DATA OF REFRIGERATION UNIT

### Main specifications

Item	Model	LXE10E
Condenser cooling system		Air cooled type
Controller		DECOS III c
Power supply		AC 3-phase 380V/400V/415V 50Hz, 440V/460V 60Hz
Compressor		Hermetic scroll type (Motor output: 5.5kW)
Evaporator		Cross fin coil type
Air-cooled condenser		Cross fin coil type
Evaporator fan		Propeller fan
Evaporator fan motor		Three-phase squirrel-cage induction motor
Condenser fan		Propeller fan
Condenser fan motor		Three-phase squirrel-cage induction motor
Defrosting	System	Hot-gas defrosting system
	Initiation	Dual timer, on-demand defrost and manual switch
	Termination	Detecting the temperature of evaporator outlet pipe and return air
Refrigerant flow control		Electronic expansion valve
Capacity control		Capacity control with hot gas bypass and suction modulating valve
Protective devices /Safety devices		Circuit breaker, PT/CT board (for over current protection). Compressor thermal protector Condenser fan-motor thermal protector Evaporator fan-motor thermal protector High-pressure switch, Fusible plug, Fuse (10A, 5A)
Refrigerant (charged amount)		R134a : 4.6 (kg)
Refrigerant oil (charged amount)		IDEMITSU, Daphne hermetic oil FVC 46D : 2.2( ℓ )
Weight		Refer to each unit specification

## 2. Names of Parts

### ● Outside

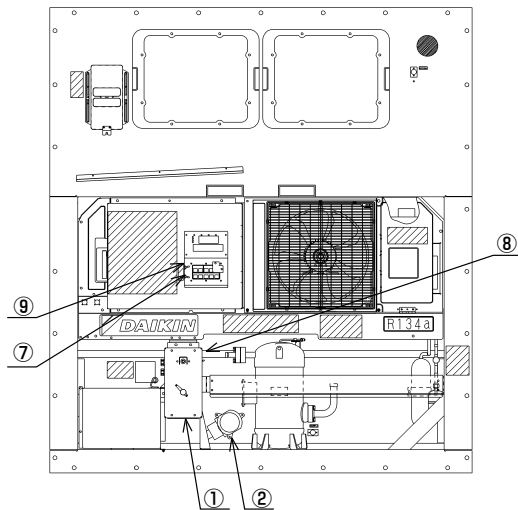

- ① Select switch box
- ② Alarm bell
- ③ Thermostat for alarm bell
- ⑦ STAND-BY ON-OFF switch (SSW)
- ⑧ Alarm bell ON-OFF switch (ALS)
- ⑨ MAIN ON-OFF switch (SSW)

### ● Inside

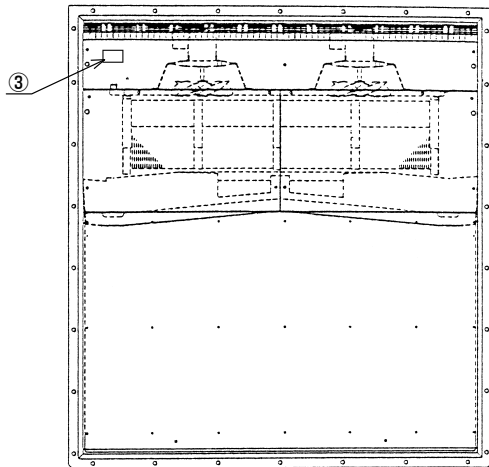

### ● Control box

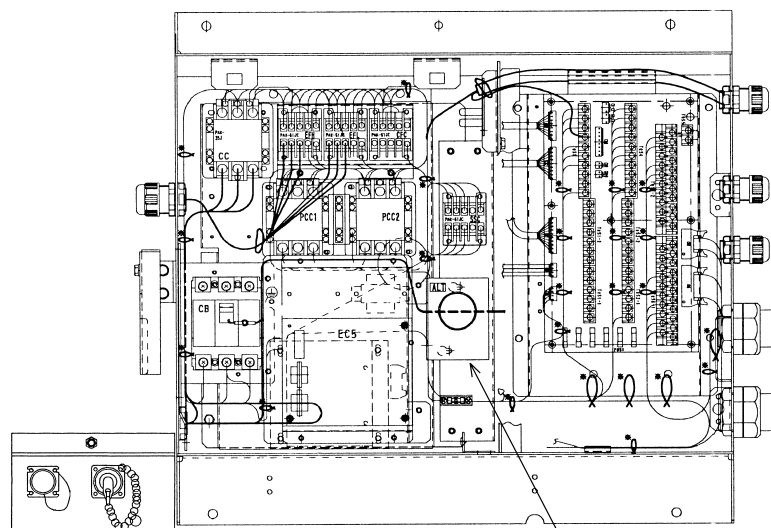

- ⑩ Safety thermostat (ALT)

### 3. Piping diagram

●LXE10E

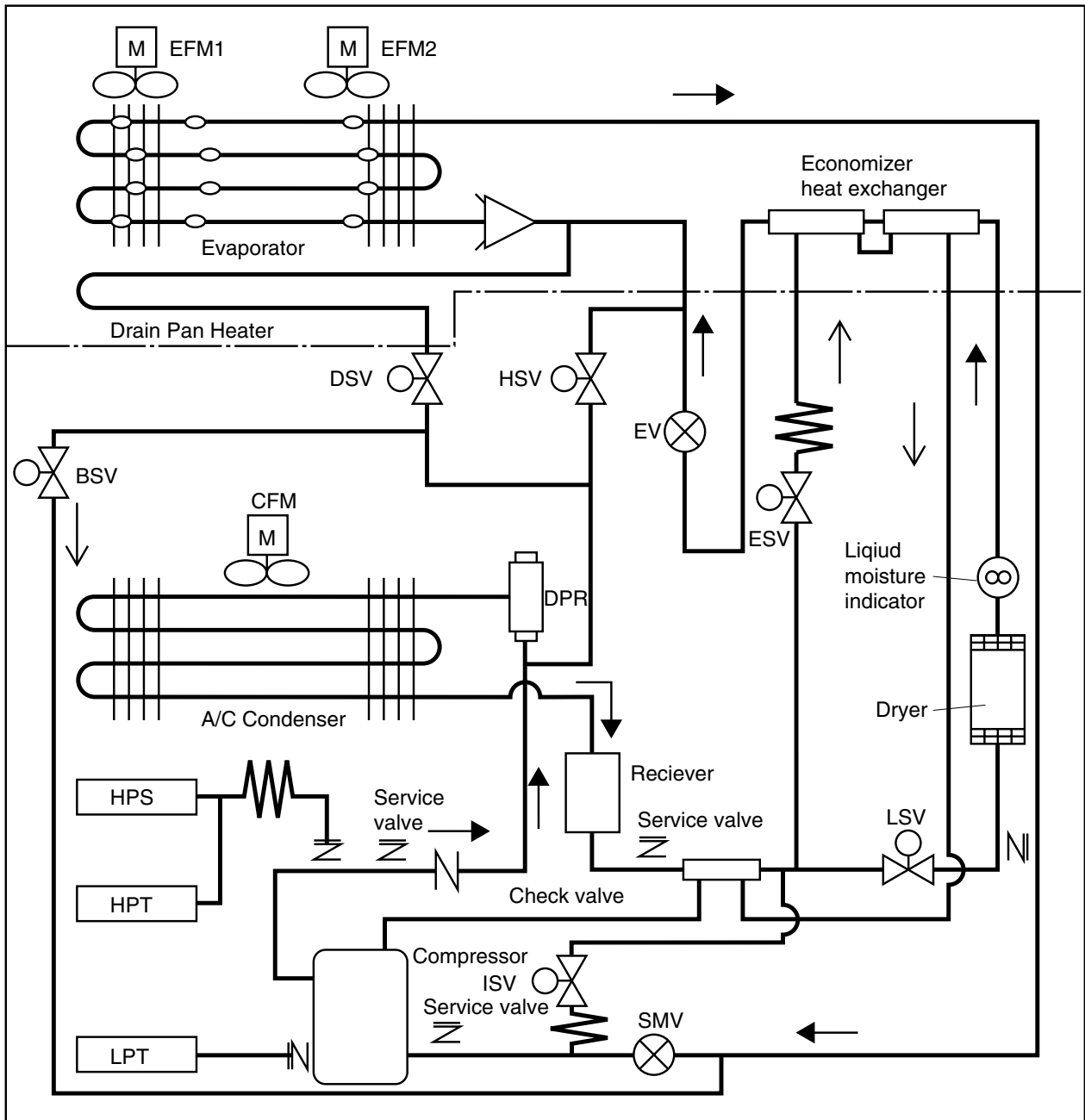

EV: Elec. Exp. Valve	SMV: Suction Modulation Valve	DPR: Discharge pressure regulator
LSV: Liquid Solenoid Valve	HSV: Hot Gas Solenoid Valve	
DSV: Defrost Solenoid Valve	ISV: Injection Solenoid Valve	
ESV: Economizer Solenoid Valve	BSV: Discharge Gas Bypass Solenoid Valve	

## 4. Operation

### 4.1 Operation instructions

Operate the unit according to the following instructions.

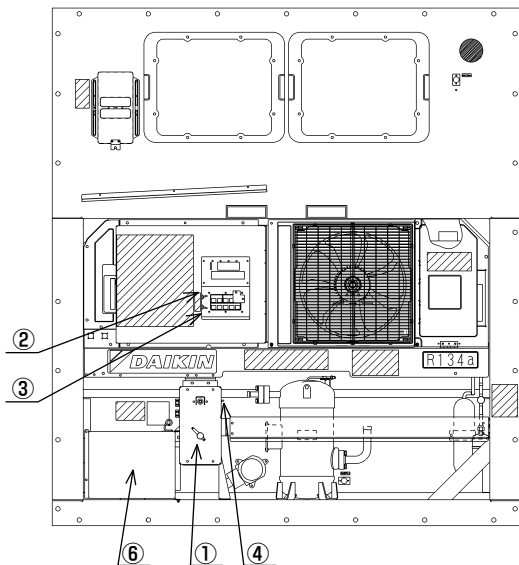

Set "MAIN" the levers of unit select switches① in both two units.

Turn "OFF" the switches of MAIN②, STAND-BY③ and ALARM④ in both two units.

Connect the power plug⑥ to the power source.

Set a new sheet of recording paper, and set the temperature controller in both units.

Turn "ON" the switch of MAIN② on the control box.

Turn "ON" the switch of ALARM④ after the inside temperature of container reaches to set temperature of thermostat for alarm bell as follows.

set temp. of thermostat for alarm bell	
on	off
+15°C (59°F)	+12°C (54°F)

Note : The scale of the setting temperature of the alarm bell shows the value of the ON mode.



## 4.2 Unit selecting instructions

Operate the unit in the opposite end of container according to the following instructions, when the unit first operated caused any troubles.

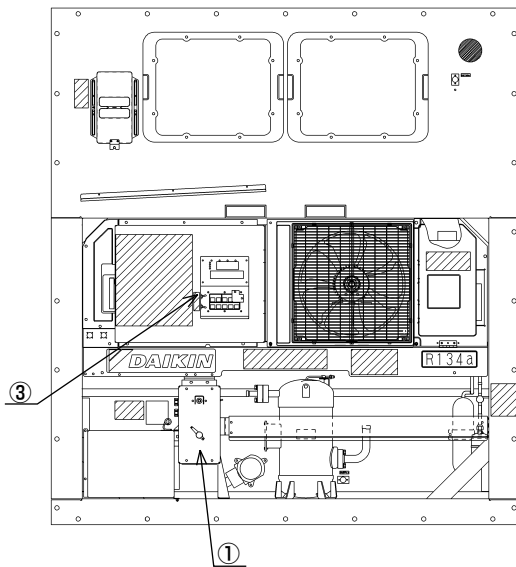

Set "STAND-BY" the lever of unit selection switch ① in the unit first operated.

Turn "ON" the switch of STAND-BY ③ in the unit caused any troubles.

The right figure explains the wirings of unit select switches.

- Thick line shows wiring when "MAIN UNIT" is operated.
- Broken line shows wiring when "STAND-BY UNIT" is operated.

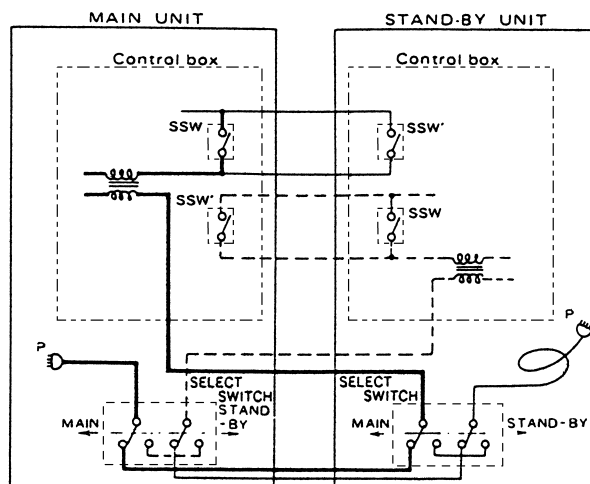

5. Schematic wiring diagram

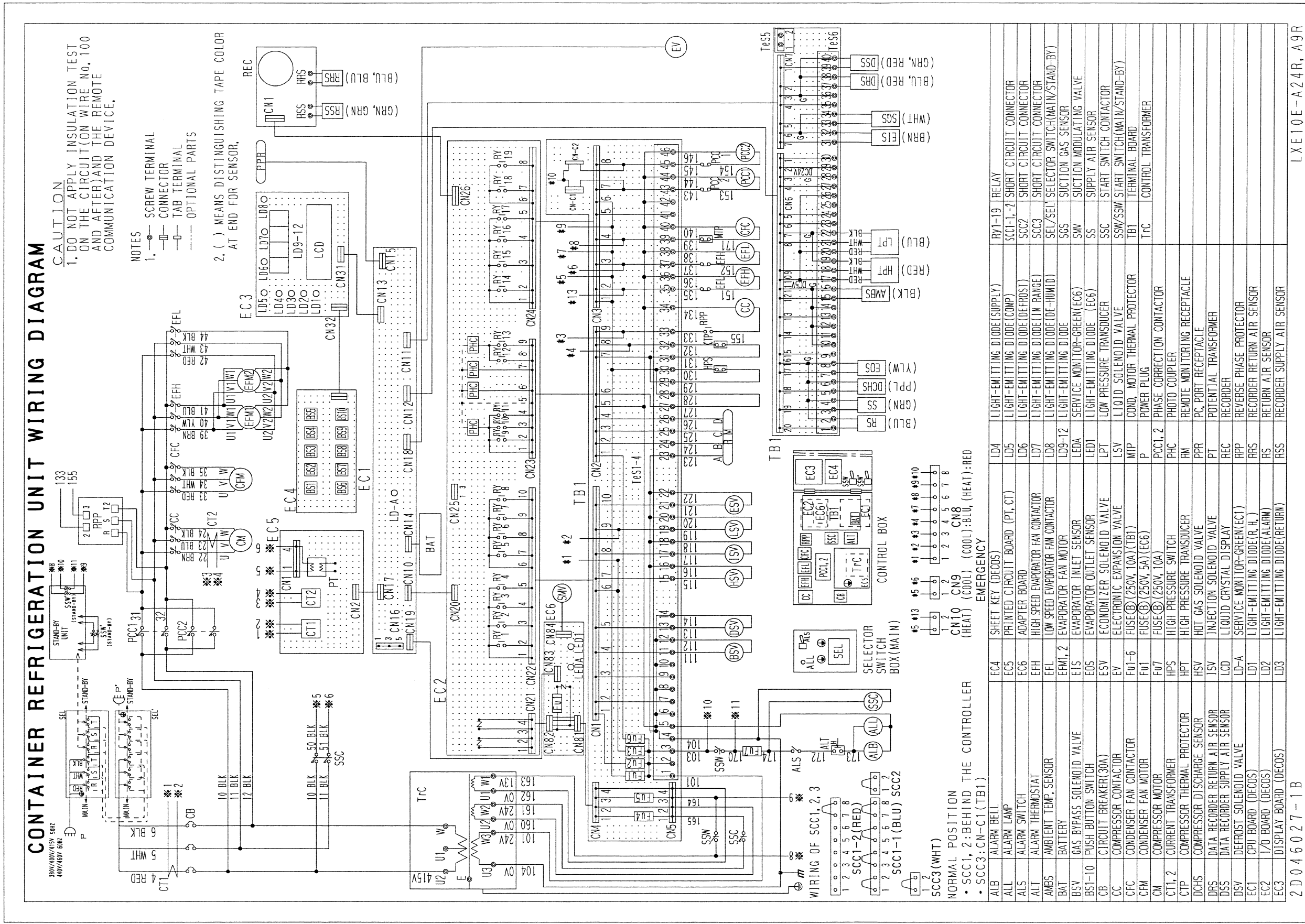

## 6. Stereoscopic wiring diagram 1/2

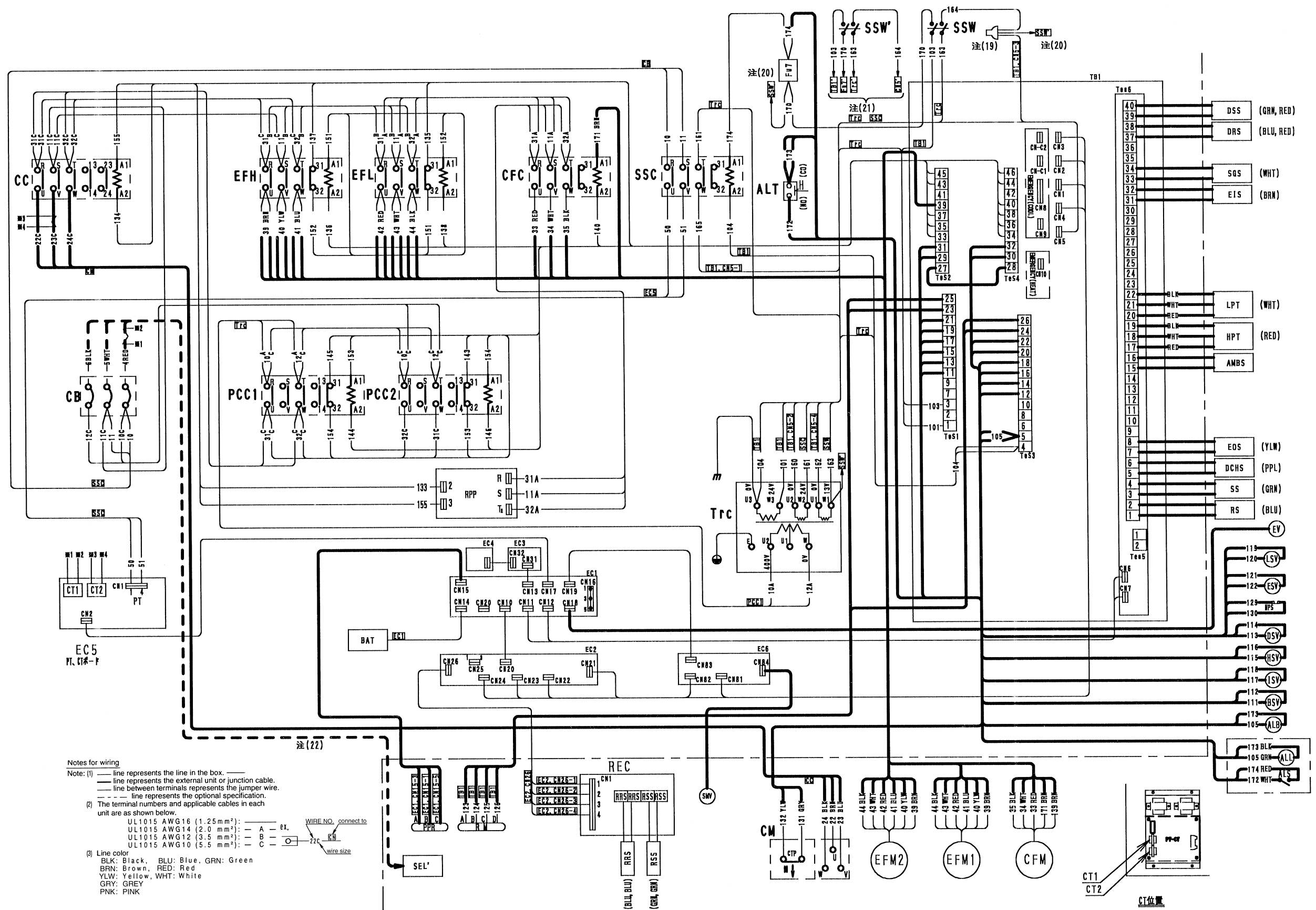

## 6. Stereoscopic wiring diagram 2/2 (MAIN-STAND By Changeover switch detail)

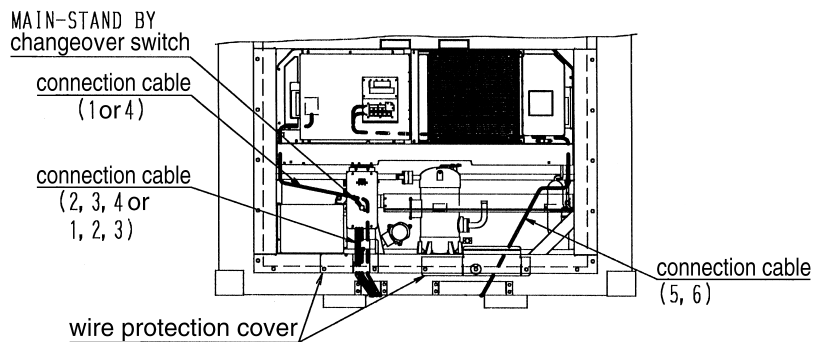
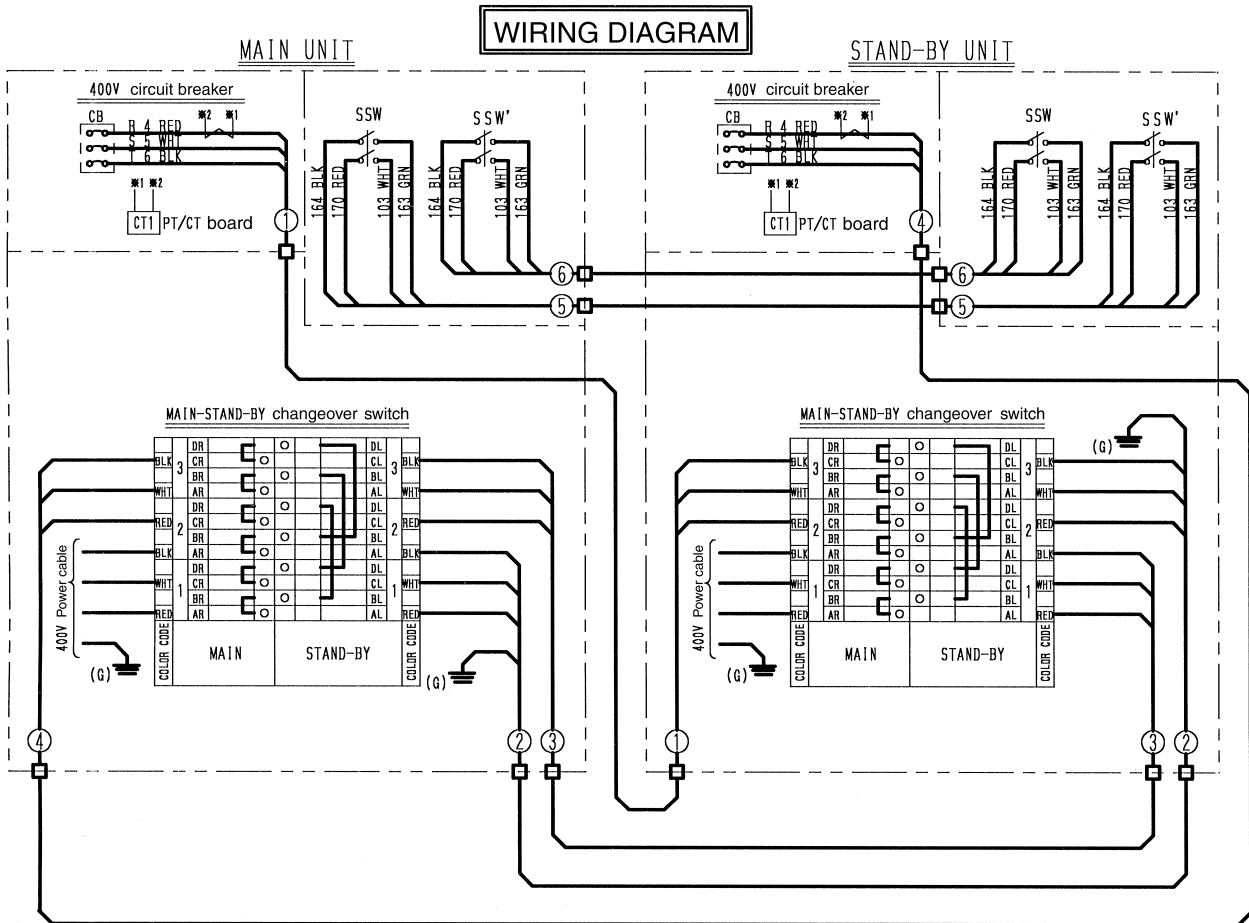

## 7. Operation of controller and recorder

When the power of the controller is turned on/off using the snap switch, the unit is turned on/off. Therefore, the indication of the controller and the record of the recorder change as follows when the snap switch is off.

NO.	Item	Changed content	
		Dual unit	Standard type
1	Indication of controller when the unit switch is off	It is not indicated.	"u-oFF" is indicated.
2	Record of recorder when the unit switch is off	Recording at over range	The in-room temperature is indicated.

## 運転操作・サービス編

(デュアル・ユニットの特殊な事項のみ記載)

本書は、デュアル・ユニットの特殊な仕様についてのみ記載しております。  
本書に記載なき事項は、別途発行の本編のLXE10E-Aサービスガイド  
(TR01-08A) を併せ参照願います。

### 改造機 LXE10E-A24R、A9R(Dual Unit Type)について

改造機の銘板には“LXE10E-A24”及び“LXE10E-A9”と記載されており、  
“R”は表示されていません。

対象機は下記の機番で判断お願い致します。

#### LXE10E-A24R

機番： 2400001 ～ 2400004までです。

#### LXE10E-A9R

機番： 2400001 ～ 2400012までです。

今回の改造内容は緊急時のユニット切替仕様です。

# 目 次

## コントロールパネル操作上の注意事項

・ 注意	15
1. 製品データ	16
主仕様	16
2. 各部の名称	17
3. 配管系統図	18
4. 運転操作	19
4.1 運転方法	19
4.2 運転ユニットの切替方法	20
5. シーケンス	21
6. 実体配線図	22
7. コントローラ及びレコーダのオペレーションについて	24

## コントロールパネル操作上の注意事項

### ⚠ 注意

ユニットの電源ON/OFF操作は必ずスナップスイッチで行なって下さい。  
(シートキーのスイッチは使用しないで下さい)

通常、コントロールパネルのシートキー上のユニットON/OFFキーは使用しないで下さい。(カバー板はとらないで下さい)

●パネル表示部(表面)

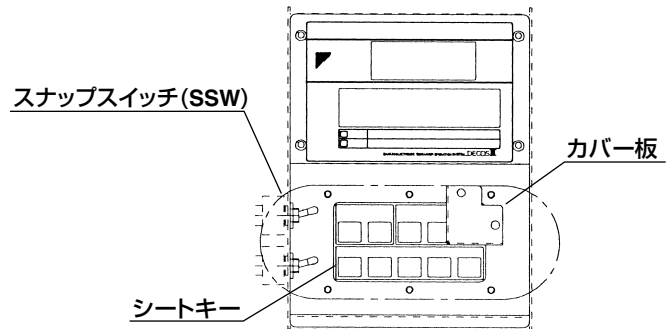

### ⚠ 注意

電池モードでユニットON/OFF設定をOFFにしないで下さい。必ずONにして下さい。

- ・設定をOFFのままにするとスナップスイッチをONしてもユニットは起動しません。
- ・電池モードの詳細説明は本編のサービスマニュアルの3.2.2各表示モード操作方法の11.電池モードを参照下さい。

### ⚠ 注意

コントローラを交換した場合は、電池モードのユニットON/OFF設定を必ずOFF→ONへ変更して下さい。

※1・コントローラ交換後下記要領で設定変更下さい。

- ①カバー板を外す
- ②スナップスイッチをONする
- ③シートキーのユニットON/OFFスイッチを押す(ユニット起動)
- ④スナップスイッチをOFFする
- ⑤カバー板を元へ戻す



## 1. 製品データ

### 主仕様

機種名		LXE10E
項目		
凝縮器冷却方式		空冷専用形
コントローラ		DECOSⅢC
電源		AC 3相 380V/400V/415V 50Hz、440V/460V 60Hz
圧縮機		全密閉スクロール形（モーター出力：5.5kW）
蒸発器		クロスフィンコイル式
空冷凝縮器		クロスフィンコイル式
蒸発器ファン		プロペラファン
蒸発器ファン用電動機		3相カゴ形誘導電動機
凝縮器ファン		プロペラファン
凝縮器ファン用電動機		3相カゴ形誘導電動機
デフロスト	方式	ホットガスデフロスト
	開始	デュアルタイマ、オンデマンドデフロストおよびマニュアルスイッチ
	終了	蒸発器出口管および吸込空気温度検知
冷媒制御		電子式膨張弁
能力制御		吸入比例弁およびホットガスバイパスによる能力制御
保護・安全装置		サーキットブレーカ、PT/CTボード（過電流保護用）、 圧縮機保護サーモ 凝縮器ファン用電動機保護サーモ、 蒸発器ファン用電動機保護サーモ、 高圧圧力開閉器、可溶栓、ヒューズ（10A、5A）
冷媒（充填量）		R134a：4.6（kg）
冷凍機油（充填量）		IDEMITSU, Daphne hermetic oil FVC 46D：2.2（ℓ）
重量		詳細は各機種の仕様書による

## 2. 各部の名称

### ●庫外

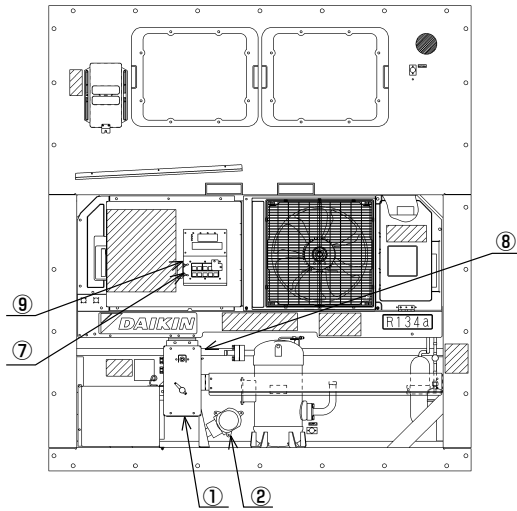

- ①セレクトスイッチボックス
- ②警報ブザー
- ③警報ブザー用サーモ
- ⑦STAND-BYユニットON-OFFスイッチ
- ⑧警報ブザー用スイッチ
- ⑨MAINユニット ON-OFFスイッチ

### ●庫内

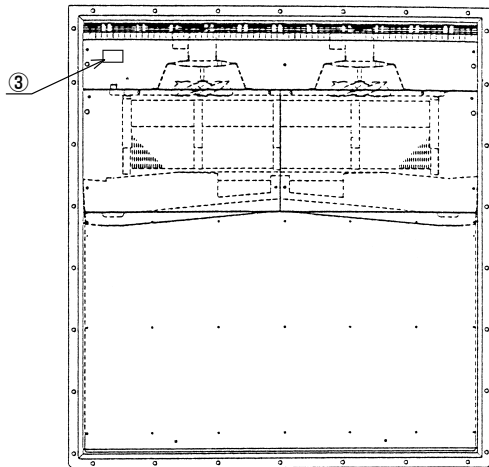

### ●コントロールボックス

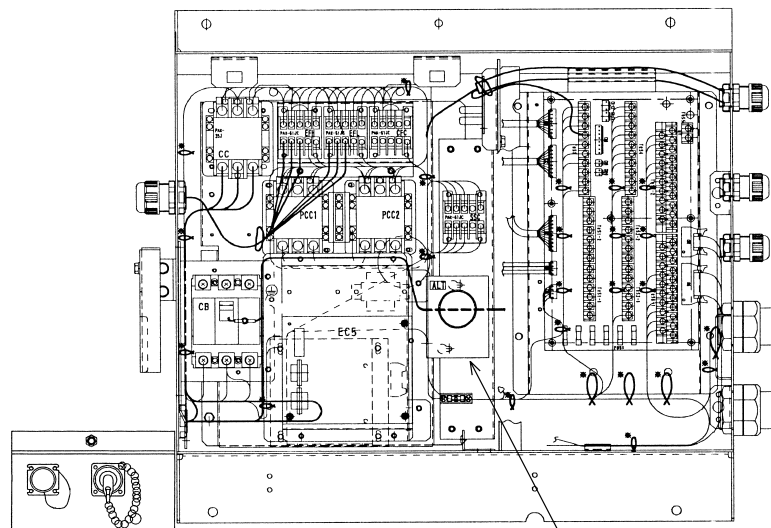

### ⑩温度調節器

### 3. 配管系統圖

●LXE10E

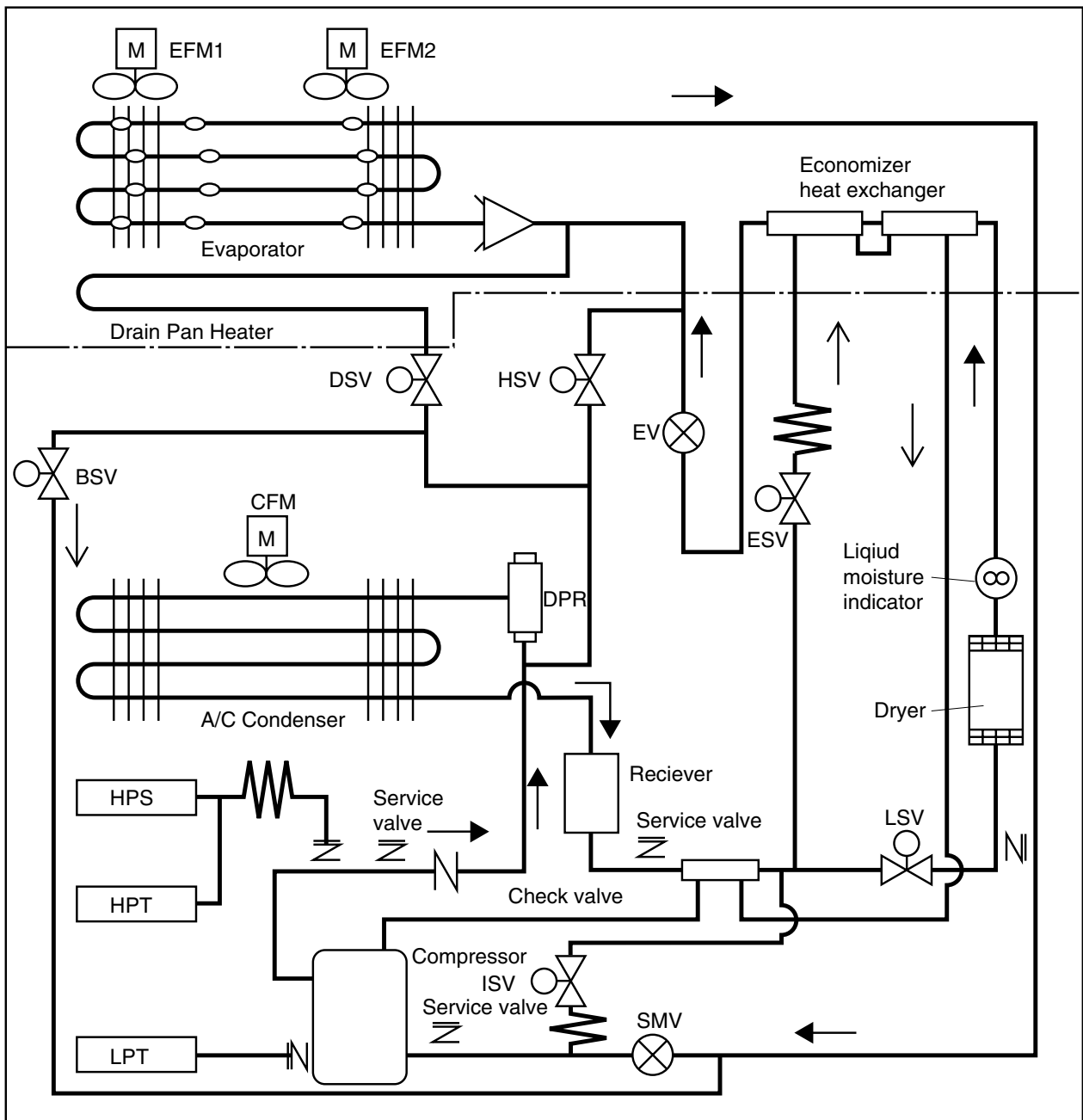

- |                               |   |                                  |
|-------------------------------|---|----------------------------------|
| EV:Elec.Exp.Valve             | SMV:Suction Modulation Valve            | DPR:Discharge pressure regulator |
| LSV:Liquid Solenoid Valve     | HSV:Hot Gas Solenoid Valve              |                                  |
| DSV:Defrost Solenoid Valve    | ISV:Injection Solenoid Valve            |                                  |
| ESV:Economizer Solenoid Valve | BSV:Discharge Gas Bypass Solenoid Valve |                                  |

## 4. 運転操作

### 4.1 運転方法

ユニットの運転は下記の手順に従って行なってください。

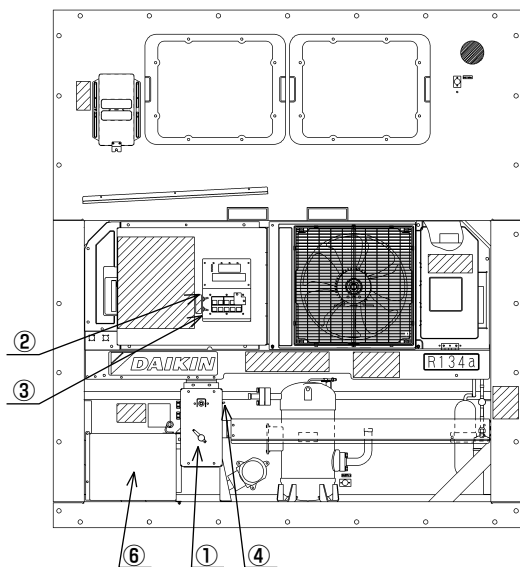

コンテナ両端の2台のユニットのユニット切替スイッチの①のレバーを“MAIN”にする。

2台のユニットのMAIN②、STAND-BY③およびALARMブザースイッチ④を全て“OFF”にする。

最初に運転するユニットの電源プラグ⑥を電源に接続する。

2台のユニットの記録計の記録紙交換・温度セットを行なう。

コントロールボックス前面のMAINスイッチ②を“ON”にする。

庫内温度が下表のALARMブザー用設定温度以下に下がった後、ALARMブザースイッチ④を“ON”にする。

set temp. of thermostat for alarm bell	
on	off
+15°C (59°F)	+12°C (54°F)

注: 警報ブザーの設定温度の目盛はON時の値を示します。

## 4.2 運転ユニットの切替方法

運転しているユニットが故障した場合、下記の手順に従ってSTAND-BYユニットに切換えて運転して下さい。

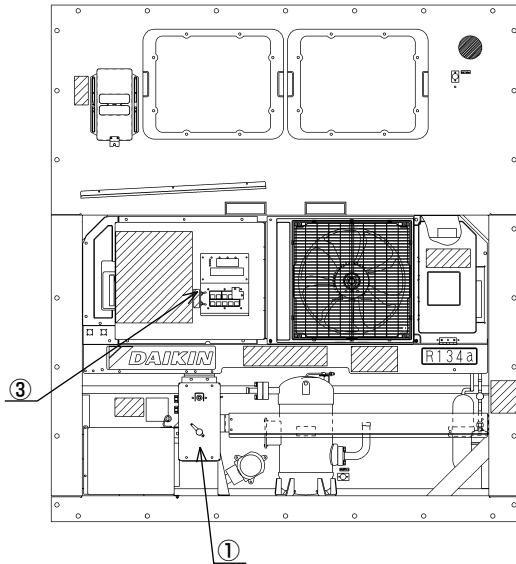

故障したユニットのユニット切換スイッチ①のレバーを“STAND-BY”にする。

故障した ユニットのSTAND-BYスイッチ③を“ON”にする。

尚、ユニット切換の原理を簡単に説明すると右図のようになります。

- 太線は“MAIN UNIT” 運転時の結線を示す。
- 破線は“STAND-BY UNIT” 運転時の結線を示す。

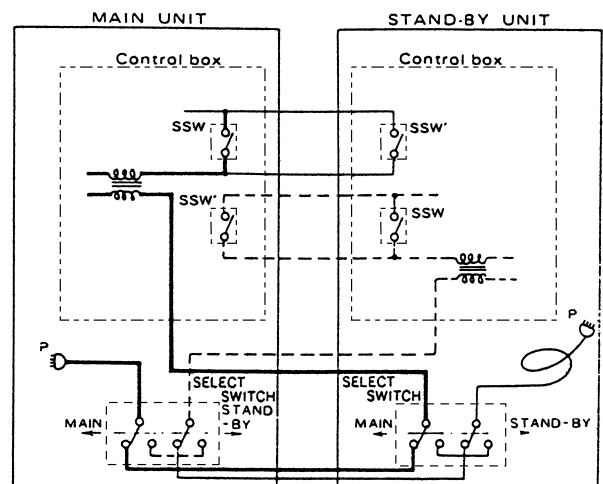

5. シーケンス

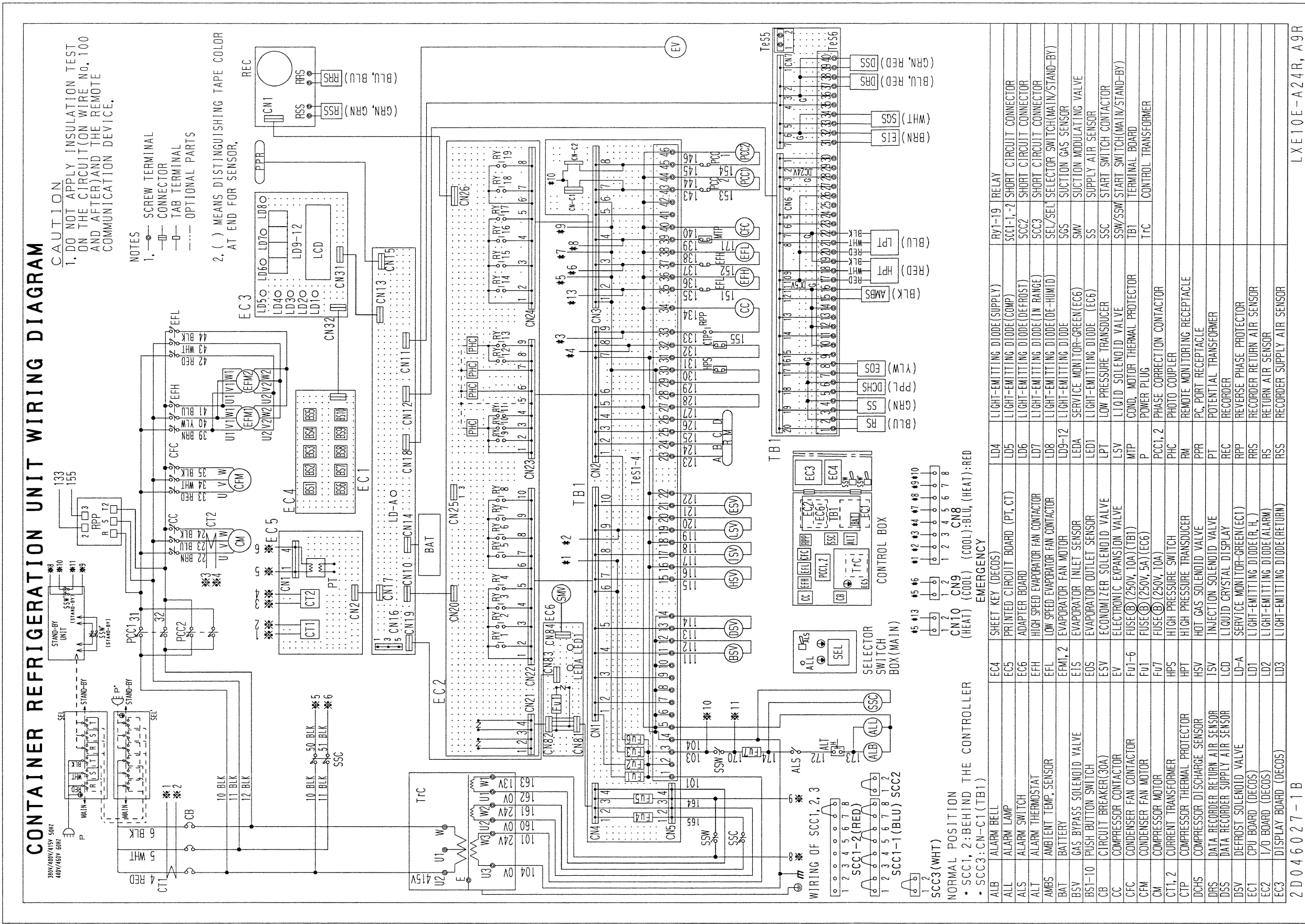

6. 実体配線図 1/2

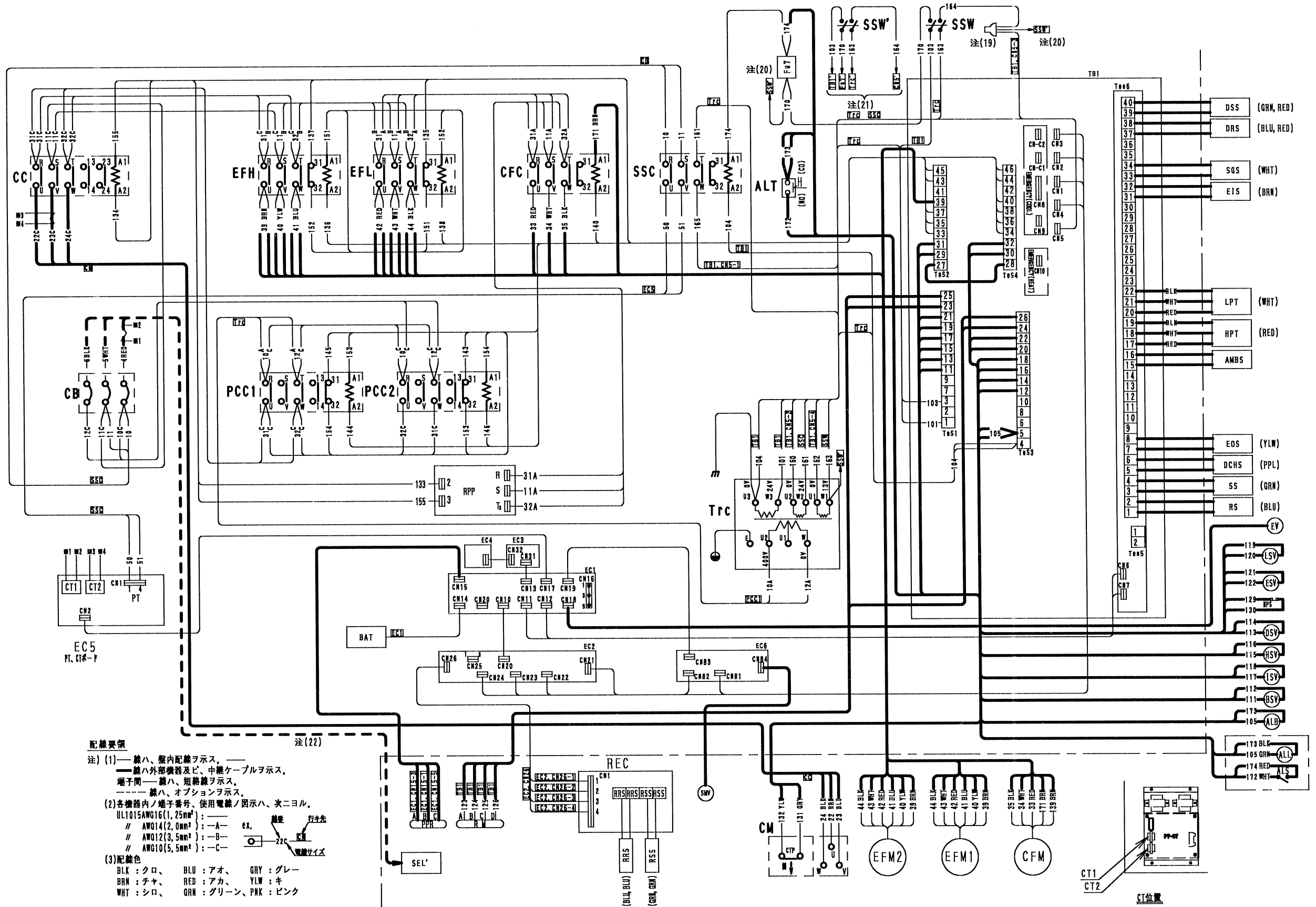

## 6. 実体配線図 2/2

### (MAIN-STAND By 切替スイッチ詳細)

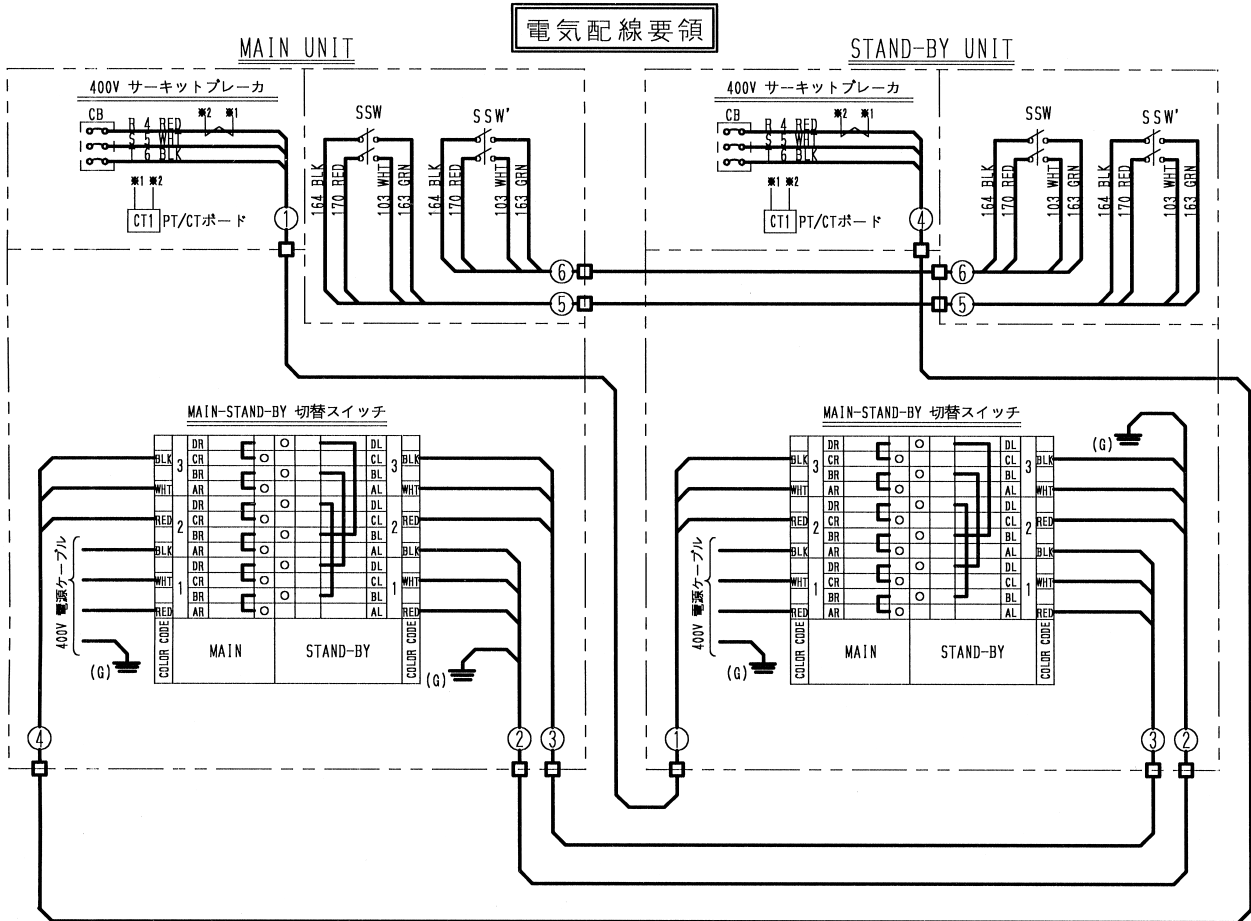

#### MAIN-STAND BY 切替スイッチ

中継ケーブル  
(1又ハ、4)

中継ケーブル  
(2, 3, 4又ハ、  
1, 2, 3)

電線保護カバー

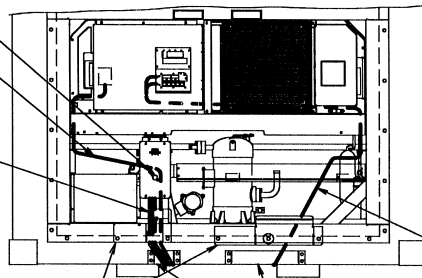

中継ケーブル  
(5, 6)

配線施行後、ケーブル  
ヲ固定スルコト  
(コンテナメーカー手配)



## 7. コントローラ及びレコーダのオペレーションについて

UNITのON/OFFは、コントローラの電源をスナップスイッチでON/OFFする事で行ないます。よって、コントローラの表示、レコーダの記録が、スナップスイッチOFFの場合、下記のように変わります。

NO.	項 目	変 更 内 容	
		デュアル・ユニット	標 準 機
1	ユニットスイッチOFF時のコントローラの表示	表示しません。	“u-oFF”を表示します。
2	ユニットスイッチOFF時のレコーダの記録	ペン振り切れ	庫内温度を表示します。

## ORDERING INSTRUCTIONS

The parts list contains the parts of the DAIKIN Marine Type Container Refrigeration Units. Please read the following items before using the list.

1. When ordering the parts, be sure to specify the model No., the name of part and the type of part. When ordering the parts for which no parts NO. is shown in the PARTS NO. column, be sure to describe DWG.NO..
2. The list shows the parts only for replacement or repairing at the job site. Certain parts require a production lead time or are supplied as a set, so please contact with the nearest DAIKIN PARTS CENTRE.

### 3. Index symbols;

Meaning of the ranking A,B and C are as follows;

#### A. The most important spare parts

1. The parts whose malfunction cause fatal damage to the unit.
2. The parts with high risk of malfunction.
3. The parts that are worn out after an extended service period.

B. The important spare parts next to A, but the risk of malfunction is not so high.

C. The parts with low risk of malfunction, but recommendable to stock to cope with damage during handling of container box and long delivery time, etc.

The parts without A, B and C mark is the parts whose necessity is not so high under normal operation.

## パーツリスト使用上の注意

このパーツリストはダイキン海上コンテナ冷凍装置の部品を集録してあります。パーツリスト使用にあたっては、必ず次の注意事項をご一読の上使用していただくようお願いいたします。

1. 部品のご注文の際は機種名、部品番号、および部品名、形式を必ずご指定ください。  
なお、部品番号欄が空白になっている部品は、図面番号で指示願います。
2. 掲載部品の範囲は、あくまでも現地にて分解修理できるところまで記載しております。  
一部部品につき納期のかかるものおよびセット単位となるものもありますので、お近くのダイキンパーツセンター又はサービスステーションに相談願います。

### 3. INDEXの説明

INDEXのA、B、Cの意味は下記の通りです。

#### A. 最も重要な部品

1. 故障した場合に最も重大な損害を与えると思われる部品
2. 故障の確率が高いと思われる部品
3. 長期の使用で摩耗して使用できなくなる部品

B. 故障発生の確率は高くはないが、Aについて重要な部品

C. 故障発生の確率は低いですが、コンテナボックスの運搬中の事故や、部品の納期が長期になるとと思われる等の理由で、在庫をお勧めする部品

A,B,Cマークの無い部品は、通常の運転では必要性は高くない部品です。

## Denomination of Model Name

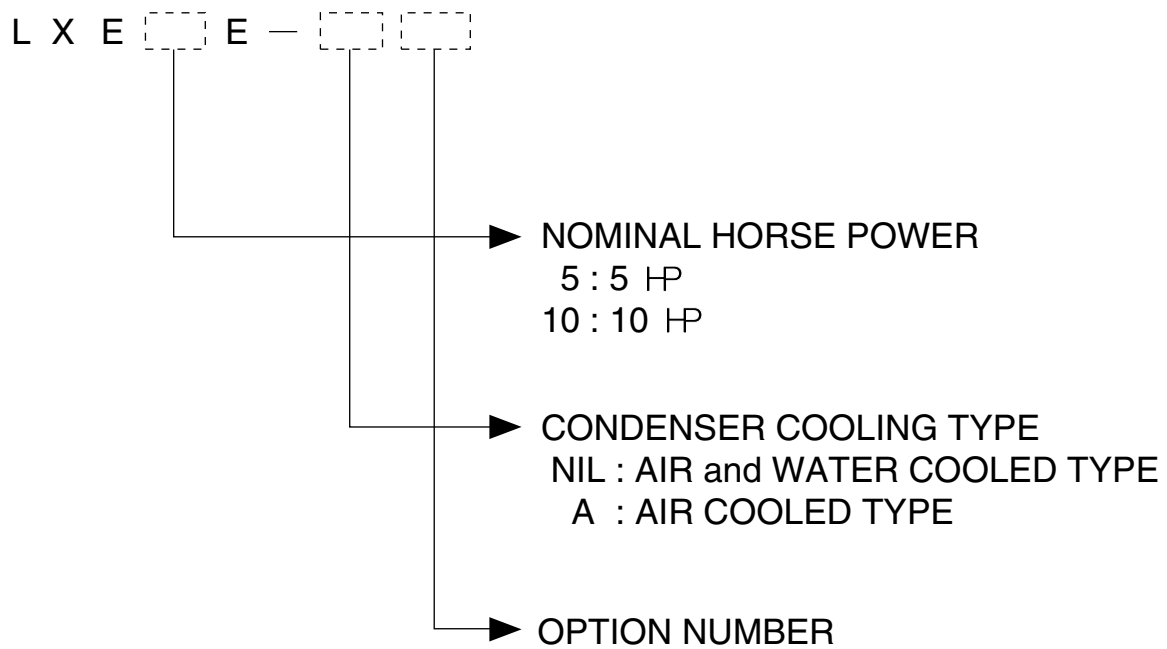

Note) "R" GIVEN AFTER OPTION NUMBER STANDS FOR "REVISION" AND IT IS GIVEN FOR THE UNIT WHICH IS SPECIALLY MODIFIED.

## 機種名について

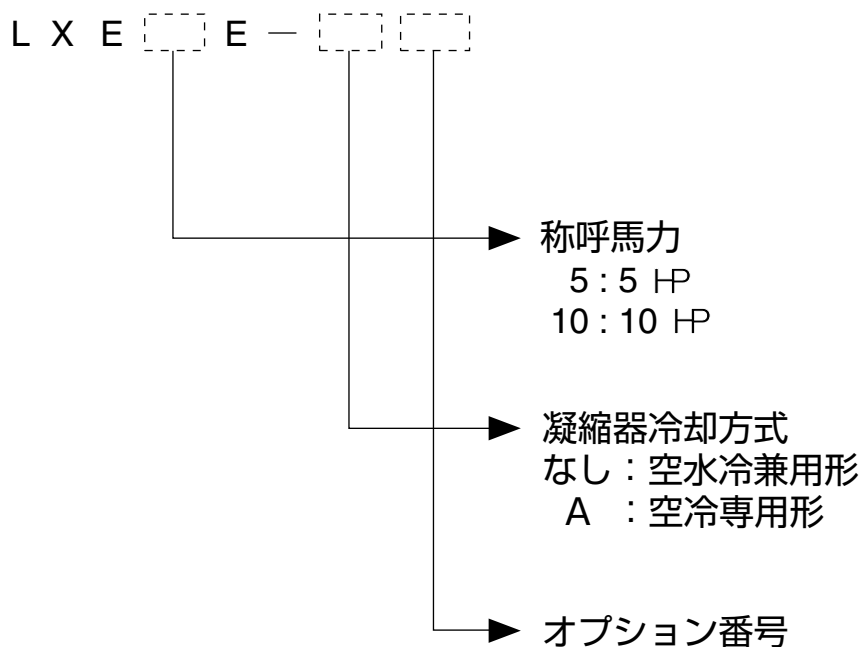

**注)** オプション番号の後に R がつく機種は、改造機で、特別な仕様が加えられていることを意味します。

<b>A. Parts related with the unit(outside)</b> .....	<b>28</b>
庫外関連部品	
<b>B. Parts related with refrigerant piping(outside)</b> .....	<b>32</b>
庫外冷媒配管関連部品	
<b>C. Parts related with the unit(inside)</b> .....	<b>36</b>
庫内関連部品	
<b>D. Parts related with refrigerant piping(inside)</b> .....	<b>38</b>
庫内冷媒配管関連部品	
<b>E. Other parts(Pipe clamp, sealing and insulation material etc.)</b> .....	<b>40</b>
その他部品 (配管固定具、シール材、防熱材等)	
<b>F. Control box</b> .....	<b>48</b>
コントローラボックス	
<b>G. Parts related with name plate</b> .....	<b>54</b>
銘板関連	
<b>H. Parts related with option 1 – Recorder box</b> .....	<b>56</b>
オプション関連部品 1 - レコーダボックス	
<b>I. Parts related with option 2 – MODEM</b> .....	<b>60</b>
オプション関連部品 2 - モデム	
<b>J. Parts related with option 3 – In door fan guard / Evaporator coil</b> .....	<b>62</b>
オプション関連部品 3 - 庫内ファンガード・蒸発器コイル関連	
1. Indoor fan guard 庫内ファンガード	
2. Evaporator coil 蒸発器コイル組立品	
<b>K. Parts related with option 4 – Power changeover switch box relating</b> .....	<b>64</b>
オプション関連部品 4 - 電源切替スイッチボックス関連	
<b>L. List of size for standard pipe clamp</b> .....	<b>66</b>
配管固定具サイズ表	
1. Resin clamp 樹脂バンド	
2. Tube clamp 管止金	
3. Cushion rubber for pipe clamp 管止金用緩衝ゴム	
<b>M. Note for ordering spare parts</b> .....	<b>68</b>
部品発注の際の注意事項	
1. Parts recommended to be ordered together with packing, gasket, sealing material and name plate	
発注の際にパッキングやシール材、銘板等の同時発注を推奨する部品	
2. Order for motorized valve, solenoid valve and pressure regulating valve	
電動弁・電磁弁・圧力調整弁の発注	
3. Order for pressure transducer 圧力センサーの発注	
4. Order for temperature sensor 温度センサーの発注	
<b>N. Measuring and adjusting tools</b> .....	<b>73</b>
測定調整用工具	
1. Tools for emergency operation 緊急運転用工具	
2. Personal computer cable (for DCCS) パソコンケーブル(DCCS用)	

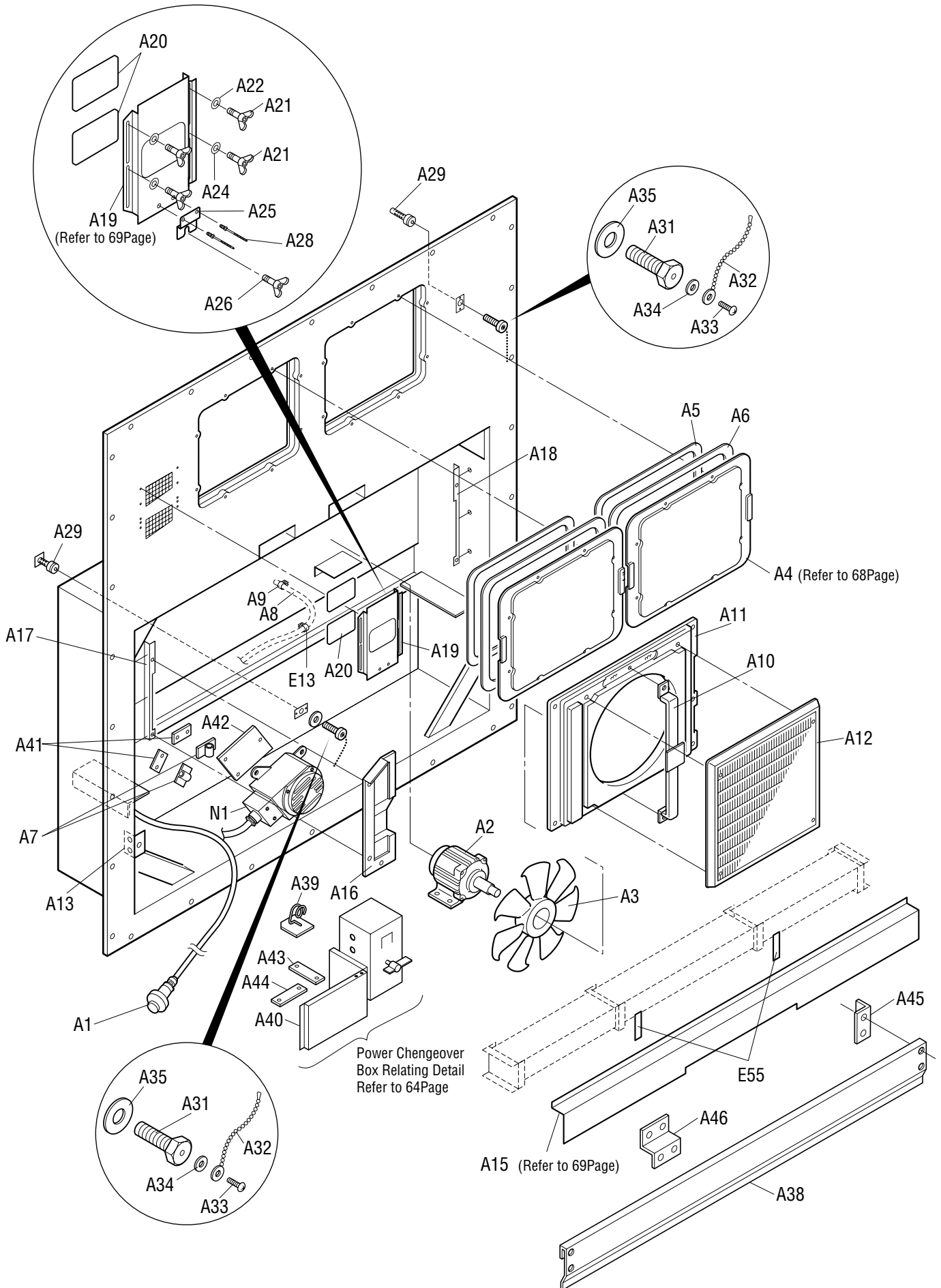

NO. 符号	INDEX	PARTS NO. 部品番号	PARTS NAME	部品名称	DWG. NO. 図面番号	TYPE SPECIFICATION 形式 仕様	QTY/UNIT		REMARKS 備考
							LXE10E-		
							A24R	A9R	
A1		1549647	Power plug (400V class)	電源プラグ (400V)	3P130172-1		1	1	
A2	A	0954936	Condenser fan motor	凝縮器電動機	3P005566-1		1	1	
A3	B	0980618	Fan Brade(outside)	プロペラファン(庫外側)	2P004956-1	P44H11S	1	1	
A4	C	1612576	Access panel ass'y	サービス扉組立品	1P006678-5		2	2	Refer to Page68
A5		1266207	Cushion material(access panel)	クッション材 (サービス扉)	3P033608-1		2	2	Refer to Page68
A6		1196113	Sealing material (access panel)	シール材 (サービス扉)	3P001640-2		2	2	Refer to Page68
A7		1326705	Wire clamp	電線止め金	4P090422-1		2	2	
A8	C	1266199	Drain hose	ドレンホース	3P011299-1	For trap type	1	1	
A9		537320	Hose band	ホースバンド	R4716528-3		2	2	
A10		1266137	Fan guide stay ass'y(outside)	ファンガイドステー組立品(庫外側)	3P027891-1		1	1	
A11		1485185	Fan guide(outside)	ファンガイド (庫外側)	1P050906-5		1	1	
A12	C	1588349	Discharge grill	吹出グリル	1PA53427-6		1	1	
A13		1369663	Mounting plate 2	ケーブル収納部取付板2	4P006981-2		1	1	
A15	C		Front plate(CA)	前板 (CA)	2P143084-1		1	1	Refer to Page69
A16		1549678	Control, box front plate(left,single)	C, BOX前板 (左)	2P093861-4		1	1	
A17		1485527	Fixing plate	外板取付板 (1)	3P116814-1		1	1	
A18		1311518	Fixing plate	外板取付板 (2)	3P047544-2		1	1	
A19	B	1266120	Ventilation cover	換気口蓋	3P067053-1		1	1	Refer to Page69
A20		1266221	Sealing material (access panel)	シール材(換気口)	4P016185-1		2	2	Refer to Page69
A21		1270345	Wing bolt	蝶ボルト	4P048681-1		4	4	
A22		1430705	Plain washer(Woods round type)	平座金 (木材用丸)	4P066385-8		4	4	
A24		0275145	Washer (wood)	平座金 (木材用)	4SK07006-6	M6	4	4	
A25		1266214	Holding plate, ventilator	押エ板	4P067052-1		1	1	
A26		1270345	Wing bolt	蝶ボルト	4P048681-1		1	1	
A28		1177509	Stainless rivet	ステンレスリベット	4P057425-1		2	2	
A29		1386923	Protection cover	温度計挿入口保護カバー	4P085921-1		2	2	
A31		1266238	Hexagon head bolt	PC六角ボルト	R4290921-125	M12X25	2	2	
A32		1386930	Latch(victor chain)	掛金 (ビクターチェーン)	4P063801-1		2	2	
A33		1266245	Tapping screw	タッピンネジ	4SK05064-8	M3 SUS304	2	2	
A34		844012S	Plain washer	平座金	4SK07005-3	M3SUS	2	2	
A35		1267084	Gasket, resin bolt	パッキン樹脂ボルト用	4PA63573-1		2	2	
A38			Front plate, compressor	圧縮機前板	3P142991-1		1	1	
A39			Cable clamp	ケーブルクランプ	3P143295-1		1	1	
A40			Front plate, (Cable / Dual)	前板板金 (ケーブル/デュアル)	3P143020-1		1	1	
A41		1503456	Insulation sheet, cable clamp	絶縁シート (電線止め金用)	4P090842-1		1	1	
A42			Insulation sheet, alarm buzzer	ク (警報ブザー用)	4P146098-1		1	1	
A43			Insulation sheet, cable clamp (1)	ケーブルクランプ絶縁シート(1)	4P144663-1		1	1	
A44			Insulation sheet, cable clamp (2)	ケーブルクランプ絶縁シート(2)	4P144663-2		1	1	
A45			Mounting plate, comp. front plate	圧縮機前板取付板	4P011561-2		1	1	
A46			Fixing plate, power changeover box	電源切替ボックス固定具	4P143118-1		1	1	

• When ordering the parts whose No. are not shown in the PARTS NO. column, be sure to describe DWG. NO..

• 部品番号欄が空白になっている部品は、図面番号で、指示願います。

Parts related with the unit(outside)  
庫外関連部品

NO. 符号	INDEX	PARTS NO. 部品番号	PARTS NAME	部品名称	DWG. NO. 図面番号	TYPE SPECIFICATION 形式 仕様	QTY/UNIT		REMARKS 備考
							LXE10E- A24R	A9R	
E13		1266788	Resin clamp	樹脂バンド	NE41015-12	MILK WHITE	4	4	
E55		1267077	Packing for prevention of vibration	C A 前板ビビリ防止パッキン	4P050050-1		2	2	
N1			Alarm buzzer	警報ブザー	ACS040084		1	1	

• When ordering the parts whose No. are not shown in the PARTS NO. column, be sure to describe DWG. NO..

• 部品番号欄が空白になっている部品は、図面番号で、指示願います。

NO. 符号	INDEX	PARTS NO. 部品番号	PARTS NAME	部品名称	DWG. NO. 図面番号	TYPE SPECIFICATION 形式 仕様	QTY/UNIT		REMARKS 備考
							LXE10E-		
							A24R	A9R	



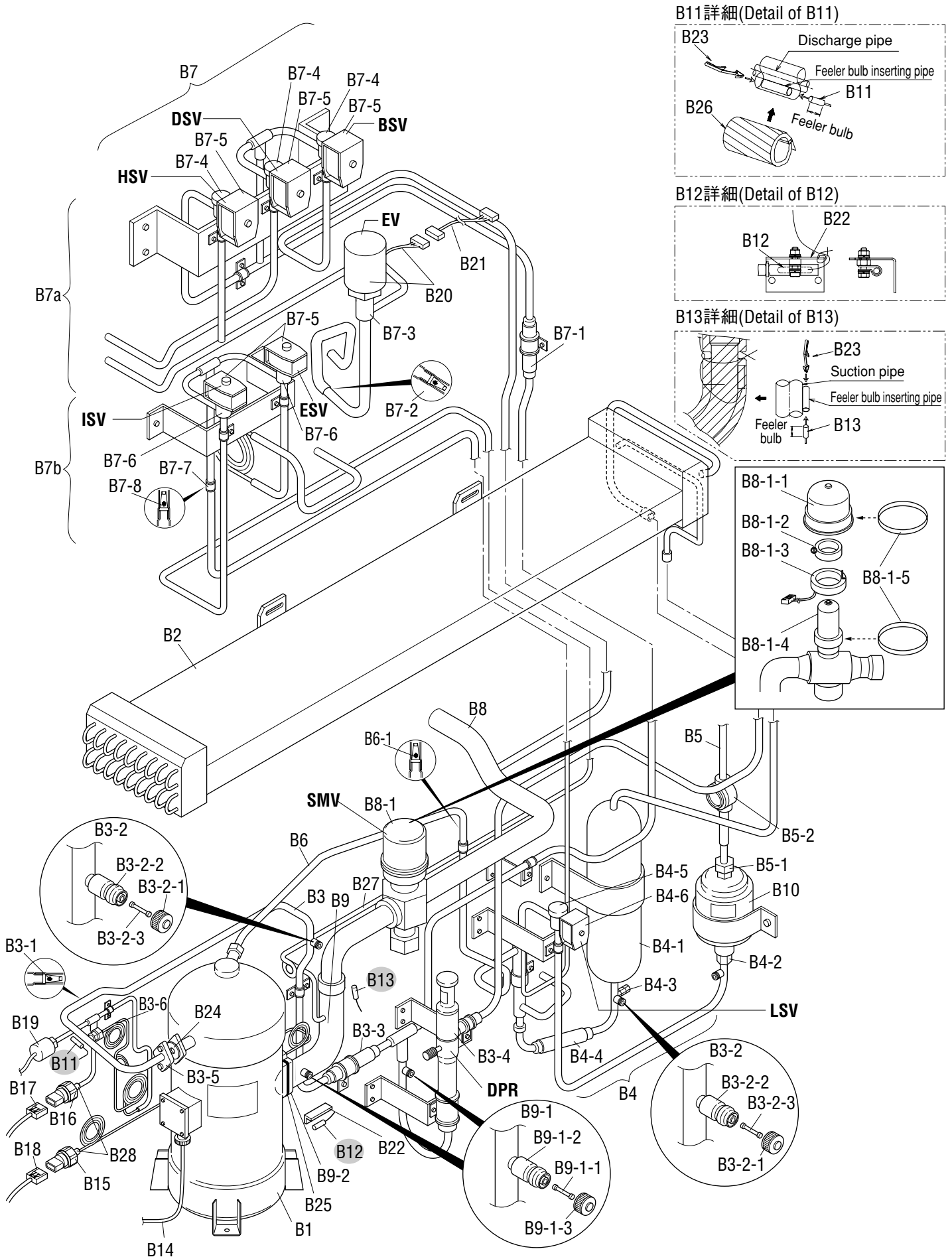

NO. 符号	INDEX	PARTS NO. 部品番号	PARTS NAME	部品名称	DWG. NO. 図面番号	TYPE SPECIFICATION 形式 仕様	QTY/UNIT		REMARKS 備考
							LXE10E-		
							A24R	A9R	
B1	A	1199415	Compressor	圧縮機	JT224D-NYR		1	1	
B2	C	1387173	Air cooled condenser		2P089486-1	CA-LXE10E1	1	1	
B3			Discharge pipe ass'y	吐出配管組立品	2P117329-1		1	1	
B3-1	C	1199167	Strainer	ストレーナ	4P051389-1		1	1	
B3-2		1178920	Service valve ass'y	サービスバルブ組立品	3P048905-1		3	3	
B3-2-1	B	1175921	Service valve cap	キャップ	3P048905-1-KU		3	3	
B3-2-2	B		Service valve body	本体	3P048905-1-KA		3	3	
B3-2-3	B	1178850	Valve core	バルブコア	3P048905-1-KI		3	3	
B3-3	B	0684220	Check valve	逆止弁	3SA27008-1		1	1	
B3-4	A	1241361	Discharge pressure regulating valve	吐出圧力調整弁	3P074558-1		1	1	Refer to Page70
B3-5		1266276	Flange(convex)	吐出管フランジ (凸)	4P065933-1		1	1	
B3-6	B	292011	Gauge joint(with check valve)	逆止弁付ゲージ接手	2PF00177-1	VCG2DA	1	1	
B4		1549685	Liquid receiver ass'y	受液器組立品	2P117335-1		1	1	
B4-1		1266283	Liquid receiver	受液器レシーバ	4P081428-1	φ 90×t1.5	1	1	
B4-2		0137856	Flare nut	フレアナット	4SK23011-4	FNS4 φ 12.7	1	1	
B4-3	A	1498035	Fusible plug	溶栓	3SA27103-1		1	1	
B4-4		0299134	Filter	フィルタ	3SA26004-2		1	1	
B4-5	A	0944566	NEV type solenoid valve body	NEV型電磁弁本体	R3305118-1	NEV-803DXF	1	1	Refer to Page70
B4-6	A	0955287	Solenoid valve coil	電磁弁コイル	3P010453-1		1	1	Refer to Page70
B5			Liquid pipe ass'y	液配管組立品	3P065985-1		1	1	
B5-1		0137856	Flare nut	フレアナット	4SK23011-4	FNS4 φ 12.7	1	1	
B5-2	A	0622107	Liquid moisture indicator	モイスターインジケーター	3PA51270-3	SGN12S	1	1	
B6			Injection tube ass'y	インジェクション管組立品	3P093305-1		1	1	
B6-1	C	0085296	Strainer	ストレーナ (100メッシュ)	R4697892		1	1	
B7			Expansion valve pipe ass'y (standard)	膨張弁配管全体組立品 (標準)	2P151404-1			1	
B7a			Expansion valve pipe ass'y	膨張弁配管組立品	2P128285-1		1		
B7b			ISV,ESV pipe ass'y	ISV・ESV配管組立品	2P115771-1		1		
B7-1		1505748	Filter	フィルタ	3P011071-1		1	1	
B7-2	C	1490846	Strainer	ストレーナ	4P051958-1		1	1	
B7-3	A	1256495	Electronic expansion valve body ass'y	電子膨張弁本体組立品	2SA50010-2-KU		1	1	Refer to Page70
B7-4	A	0944566	NEV type solenoid valve body	NEV型電磁弁本体	R3305118-1	NEV-803DXF	3	3	Refer to Page70
B7-5	A	1266290	Solenoid valve coil	電磁弁コイル	3P010453-2		3	3	Refer to Page70
B7-6	A	0088738	Nev type solenoid valve body	NEV型電磁弁本体	R3305099-1-KI	NEV-202DXF	2	2	Refer to Page70
B7-7	A	1266290	Solenoid valve coil	電磁弁コイル	3P010453-2		2	2	
B7-8	C	0964166	Strainer	ストレーナ	4P012568-1		1	1	
B8		1496781	Suction pipe ass'y(inside)	吸入配管組立品 (庫内)	3P071569-2		1	1	
B8-1	A	1254538	Suction modulating valve ass'y	吸入比例弁組立品	2P078385-1		1	1	Refer to Page70
B8-1-1		1270376	Upper cover, suction modulating valve	吸入比例弁カバー上	2P078385-1-KA		1	1	
B8-1-2		1496914	Clamp, suction modulating valve	吸入比例弁クランプ	2P078385-1-KI		1	1	
B8-1-3		1270390	Coil, suction modulating valve	吸入比例弁コイル	2P078385-1-KU		1	1	

● When ordering the parts whose No. are not shown in the PARTS NO. column, be sure to describe DWG. NO..

● 部品番号欄が空白になっている部品は、図面番号で、指示願います。

Parts related with refrigerant piping(outside)  
庫外冷媒配管関連部品

NO. 符号	INDEX	PARTS NO. 部品番号	PARTS NAME	部品名称	DWG. NO. 図面番号	TYPE SPECIFICATION 形式 仕様	QTY/UNIT		REMARKS 備考
							LXE10E-		
							A24R	A9R	
B8-1-4		1270408	Body, suction modulating valve	吸入比例弁弁本体	2P078385-1-KE		1	1	
B8-1-5		1270415	Cover band, suction modulating valve	吸入比例弁カバーバンド	2P078385-1-KO		2	2	
B9			Suction piping ass'y(1)	吸入配管組立品 (1)	2P143309-1		1	1	
B9-1	C	1178937	Service valve ass'y	サービスマルブ組立品	3P048907-1		2	2	
B9-1-1	B	1178867	Valve core	バルブコア	3P048907-1-KI		2	2	
B9-1-2	B		Service valve body	本体	3P048907-1-KA		2	2	
B9-1-3	B	1175914	Service valve cap	キャップ	3P048907-1-KU		2	2	
B9-2		1266315	Square flange	角フランジ	4PA61542-1		1	1	
B10	A	1241385	Drier ass'y	ドライヤ組立品	3P069859-1		1	1	
B11	A	0983321	Sensor, discharge pipe temperature(DCHS)	吐出管用センサ(D C H S)	3SA48009-10		1	1	Refer to Page72
B12	A	0798321	Sensor, ambient air temperature(AMBS)	外気温度センサ(A M B S)	3PA61769-6	ST9503-6(NIL)	1	1	Refer to Page72
B13	A	0983338	Sensor, comp suction pipe temperature(SGS)	圧縮機吸込配管温度用センサ(S G S)	3PA61769-9	ST9503-9(white)	1	1	Refer to Page72
B14		1266322	Cable(compressor)	ケーブル (圧縮機)	3P063458-1		1	1	
B15	A	1587942	Low pressure transducer (LPT)	低圧圧力センサ (LPT)	3P141601-1	SPCL02	1	1	Refer to Page71
B16	A	1587959	High pressure transducer (HPT)	高圧圧力センサ (HPT)	3P141602-1	SPCH01	1	1	Refer to Page71
B19	A	1241378	High pressure switch	高圧圧力開閉器 ACB-KB15	3P071506-1		1	1	
B20	A	1381430	Electronic expansion valve coil	電子膨張弁コイル	2P010454-2		1	1	Refer to Page70
B21	A	1266339	Wire harness(EV junction cable)	ワイヤハーネス (EV中継ケーブル)	3P059954-1		1	1	
B22		1605453	Thermostat cover	サーモカバー	4P144439-1		1	1	
B23		0423968	Mounting spring,thermistor	サーミスタ取付バネ	4PA38890-1		3	3	
B24	A	0132192	Flange packing, compressor discharge	圧縮機吐出側フランジパッキン	4SK20053-4		1	1	
B25	A	0395032	Flange packing, compressor suction	圧縮機吸入側フランジパッキン	R4221042-1		1	1	
B26		1267147	Thermal insulation tube	断熱筒 (吸入弁庫外側)	4P073602-1		1	1	
B27			ISV outlet pipe ass'y	ISV出口連絡管組立品	3P143754-1		1	1	
B28		253101	Union joint	ユニオン継手	N142011-1		2	2	

• When ordering the parts whose No. are not shown in the PARTS NO. column, be sure to describe DWG. NO..  
• 部品番号欄が空白になっている部品は、図面番号で、指示願います。

NO. 符号	INDEX	PARTS NO. 部品番号	PARTS NAME	部品名称	DWG. NO. 図面番号	TYPE SPECIFICATION 形式 仕様	QTY/UNIT		REMARKS 備考
							LXE10E-		
							A24R	A9R	

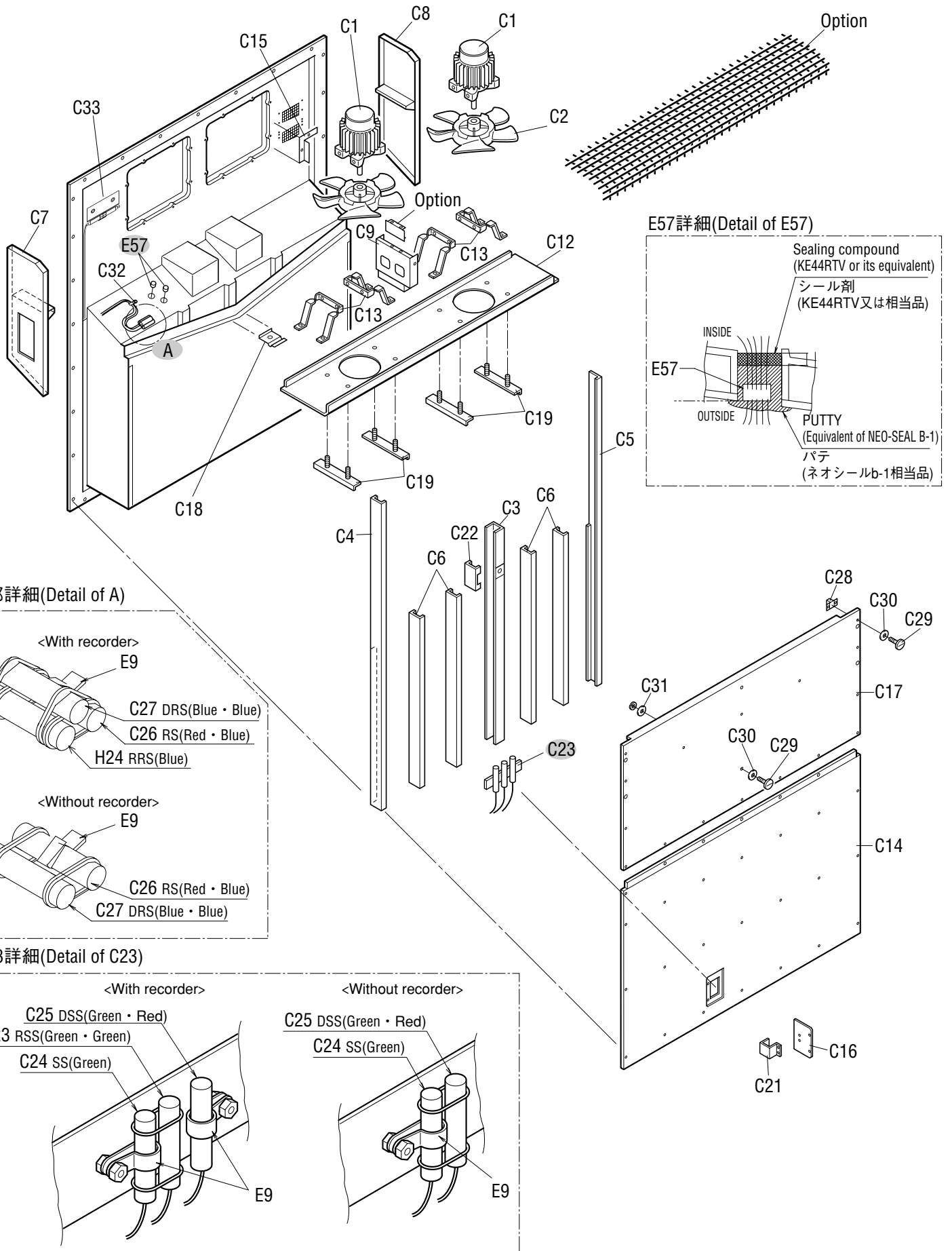

NO. 符号	INDEX	PARTS NO. 部品番号	PARTS NAME	部品名称	DWG. NO. 図面番号	TYPE SPECIFICATION 形式 仕様	QTY/UNIT		REMARKS 備考
							LXE10E-		
							A24R	A9R	
C1	A	0955340	Three phase AC fan motor	三相交流ファン電動機	3PA07524-5	SPRK91A - 42	2	2	
C2	B	0777519	Fan Brade(inside)	ブロペラファン(庫内側)	P32P11F		2	2	
C3		1410958	Center stay	中央ステー	3P094853-1		1	1	
C4		1266360	Side stay	サイドステー	3P061281-1	t2.5	1	1	
C5		1266377	Side stay(2)	サイドステー (2)	3P061282-1	t2.5	1	1	
C6		1410965	Rear stay	背面ステー	3P094854-1		4	4	
C7		1266391	Casing frame,evaporator(left)	蒸発器枠 (1)	2P071765-1		1	1	
C8		1266409	Casing frame,evaporator(right)	蒸発器枠 (2)	2P071765-2		1	1	
C9		1410509	Fan guide fixing plate	ファンガイド固定板	3P083180-1		1	1	
C12		1587872	Fan guide ass'y	ファンガイド組立品(標準仕様)	3P123264-5		1	1	
C13		1565199	Fan motor stand LEG(1)	ファン電動機台(脚)組立品(1)	3P144888-1		4	4	
C14		1564893	Rear plate(lower)	裏板(下)パッフルプレート穴	2P094959-3		1	1	
C15		1266555	Air reflection plate	風向板	4P055257-1		1	1	
C16		1380817	Inspection door(supply sensor)	点検蓋(サブライセンサ)	4P094961-1		1	1	
C17		1266478	Rear plate(upper)	裏板(上)標準	2P080871-1		1	1	
C18		1266485	Partition plate (drain outlet)	仕切板(ドレン出口)	4P011317-1		1	1	
C19		1135978	Reinforce plate, fan motor	補強板(ファン電動機台)	4P011316-1		4	4	
C21		1135125	Hinge	蝶番	3P043374-1		1	1	
C22		1266524	Support plate	支柱補強柱	4P061342-1		1	1	
C23		1266517	Mounting plate, sensor	センサー取付板	3P069038-1		1	1	
C24	A	0798299	Sensor(SS)	センサー(S S)	3PA61769-3	ST9503-3(green)	1	1	Refer to Page72
C25	A	0798770	Sensor(DSS)	センサー(D S S)	3PA61769-8	ST9503-8(green, red)	1	1	Refer to Page72
C26	A	0798275	Sensor(RS)	センサー(R S)	3PA61769-1	ST9503-1(blue)	1	1	Refer to Page72
C27	A	0798732	Sensor(DRS)	センサー(D R S)	3PA61769-7	ST9503-7(blue,red)	1	1	Refer to Page72
C28		860015	Universal nut	自在ナット	R4713188-1		20	20	
C29		860030S	Speed bolt	スピードボルト (M6)	4P048680-2	M6X29(S)	20	20	
C30		860005	Washer, speed bolt	スピードボルト用座金	R4713334		20	20	
C31		840002	Drop out prevention washer	脱落防止座金	R4718607-6		2	2	
C32		388339	Fixture	固定具	4PA11782-1		3	3	
C33			Mounting plate, thermostat sensor	温度サーモ取付板	4P144378-1		1	1	
E9		0118273	Resin clamp	樹脂バンド	NE41015-2	MILK WHITE	4	4	
E57		1267091	Wiring protection bush	配線保護ブッシュ	4P023920-1	BLACK	2	2	
H23	A	0798307	Sensor (RSS)	センサー (R S S)	3PA61769-4	ST9503-4 (Green, Green)	1	1	
H24	A	0798282	Sensor (RRS)	センサー (R R S)	3PA61769-2	ST9503-2 (Blue, Blue)	1	1	

● When ordering the parts whose No. are not shown in the PARTS NO. column, be sure to describe DWG. NO..

● 部品番号欄が空白になっている部品は、図面番号で、指示願います。

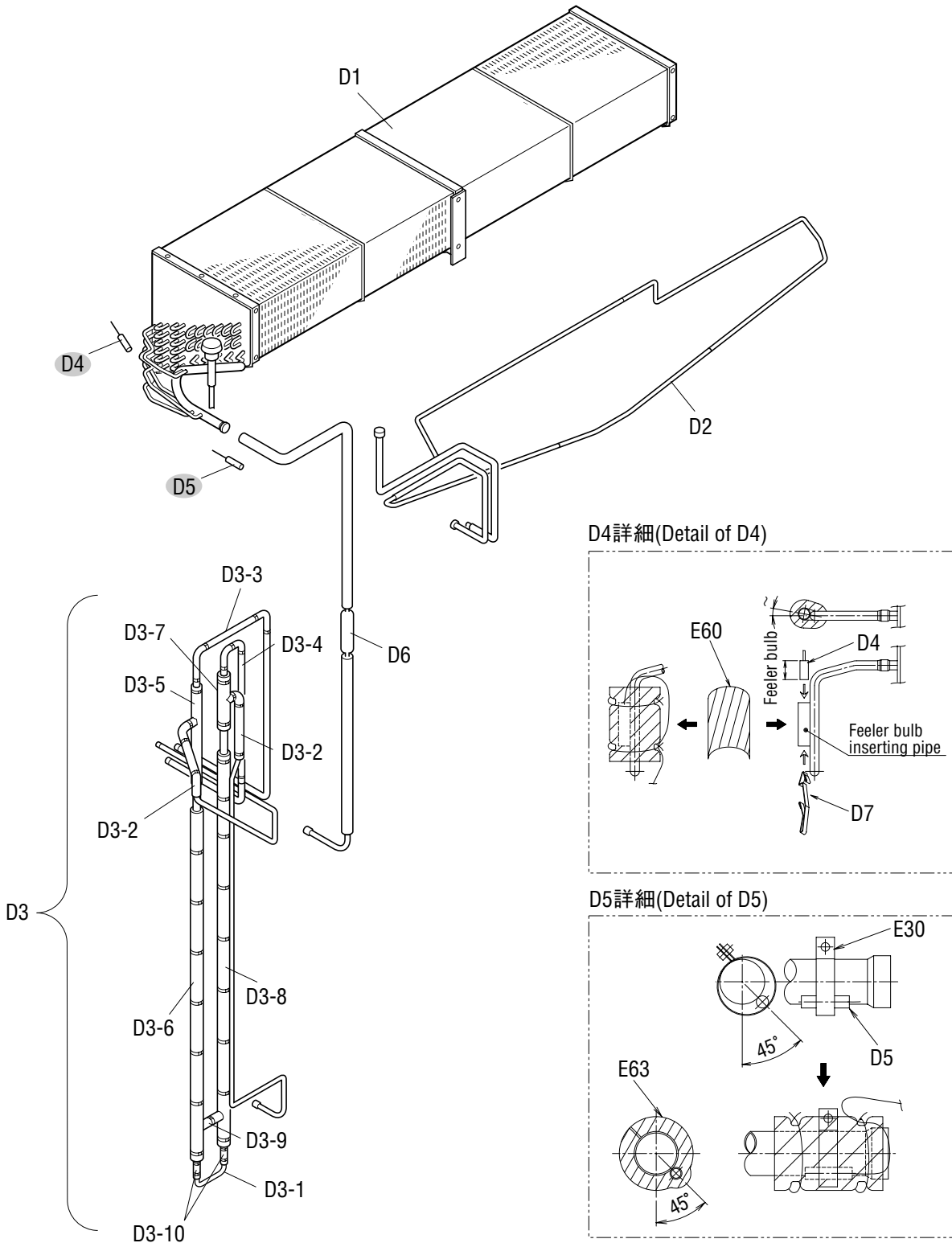

NO. 符号	INDEX	PARTS NO. 部品番号	PARTS NAME		DWG. NO. 図面番号	TYPE SPECIFICATION 形式仕様	QTY/UNIT		REMARKS 備考
				部品名称			LXE10E-		
							A24R	A9R	
D1		1562789	Evaporator	蒸発器組立品	2P089487-1	CRB-LXE10E5	1	1	
D2		1564677	Ass'y for pipe of drain pan	ドレンパン配管組立品	2P122137-2		1	1	
D3		1564684	Double tube heat exchanger ass'y with insulation	熱交換器防露筒組立品	3P114529-2		1		
D3		1612583	Double tube heat exchanger ass'y with insulation	熱交換器防露筒組立品	3P143786-2			1	
D3-1			Double tube heat exchanger ass'y	二重管式熱交換器組立品	2P114495-2		1		
D3-1			Double tube heat exchanger ass'y	二重管式熱交換器組立品	2P143779-2			1	
D3-2		1549762	Gas pipe(1)	ガス配管 (1) 防露筒	3P114518-1		2	2	
D3-3		1549779	Liquid pipe(1)	液配管 (1) 防露筒	3P114518-2		1	1	
D3-4		1549786	Liquid pipe(2)	液配管 (2) 防露筒	3P114518-3		1	1	
D3-5		1380918	Thermal insulation tube	断熱筒 (熱交外管)	4P103439-1		1	1	
D3-6		1380925	Thermal insulation tube	断熱筒 (熱交外管)	4P103439-2		1	1	
D3-7		1380932	Thermal insulation tube	断熱筒 (熱交外管)	4P103439-3		1	1	
D3-8		1380949	Thermal insulation tube	断熱筒 (熱交外管)	4P103439-4		1	1	
D3-9		1549971	Gas pipe(3)	ガス配管 (3) 防露筒	3P114518-4		1	1	
D3-10		1549988	Liquid pipe(3)	液配管 (3) 防露筒	4P110520-2		2	2	
D4	A	1562828	Senser(EIS)	センサー ( E I S )	3P012118-2		1	1	Refer to Page72
D5	A	1562835	Senser(EOS)	センサー ( E O S )	3PA61769-15		1	1	Refer to Page72
D6		1266308	Filter	フィルタ	3P032328-1		1	1	
D7		0423968	Mounting spring,thermistor	サーミスタ取付バネ	4PA38890-1		1	1	
E30		537320	Hose band	ホースバンド	R4716528-3		2	2	
E60		1267123	Thermal insulation tube piping	断熱筒配管緩衝材	4P011309-1		5	5	
E63		1267154	Insulation tube evaporater header	蒸発器ヘッダー防露筒	4P073525-1		1	1	

● When ordering the parts whose No. are not shown in the PARTS NO. column, be sure to describe DWG. NO..  
● 部品番号欄が空白になっている部品は、図面番号で、指示願います。



Other parts(Pipe clamp, sealing and insulation material etc.)  
 その他部品 (配管固定具、シール材、防熱材等)

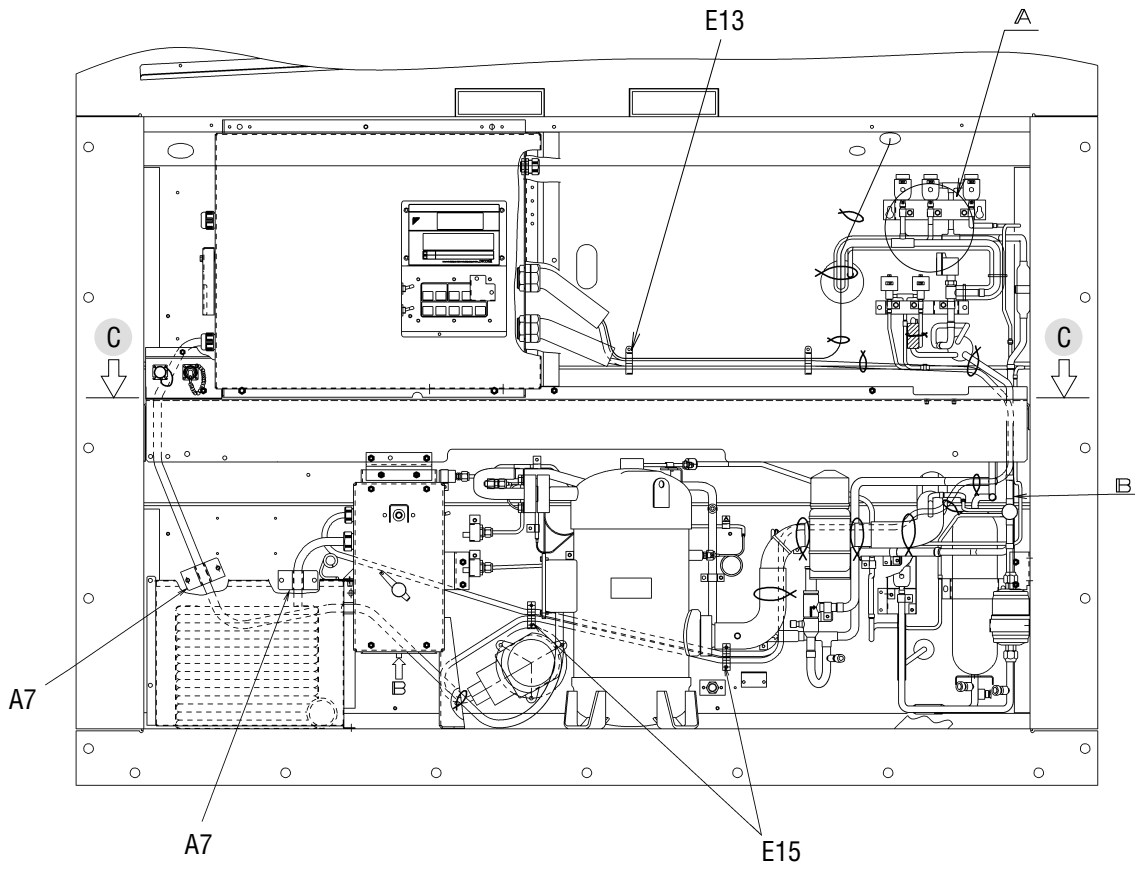

A詳細(Detail of A)

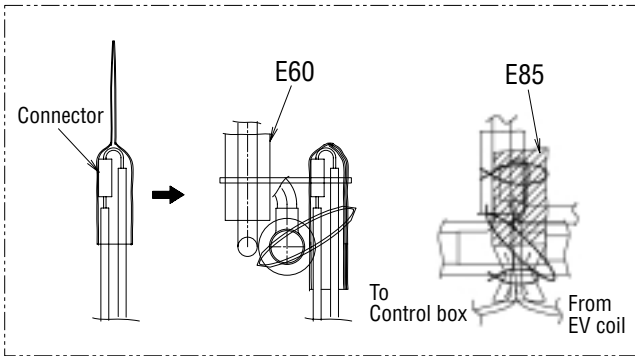

B詳細(Detail of B)

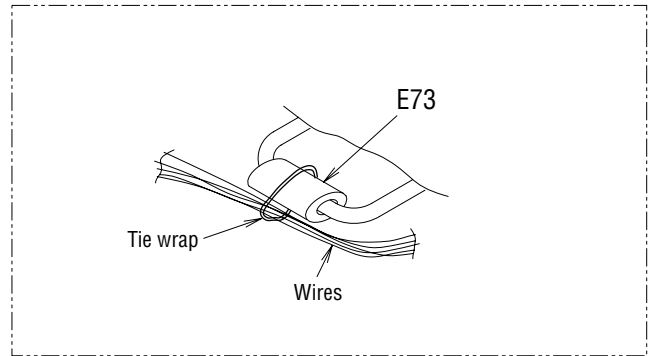

C断面(Section of C)

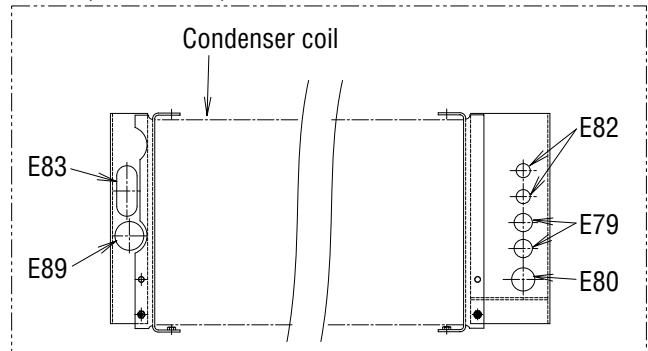

※(L = XX mm) indicates the length of cushion rubber E35. (Cut to suit pipe size.)

※(L = XX mm)と表記のものは、緩衝ゴム(E35)の長さです。(配管のサイズに合わせて切って使用ください。)

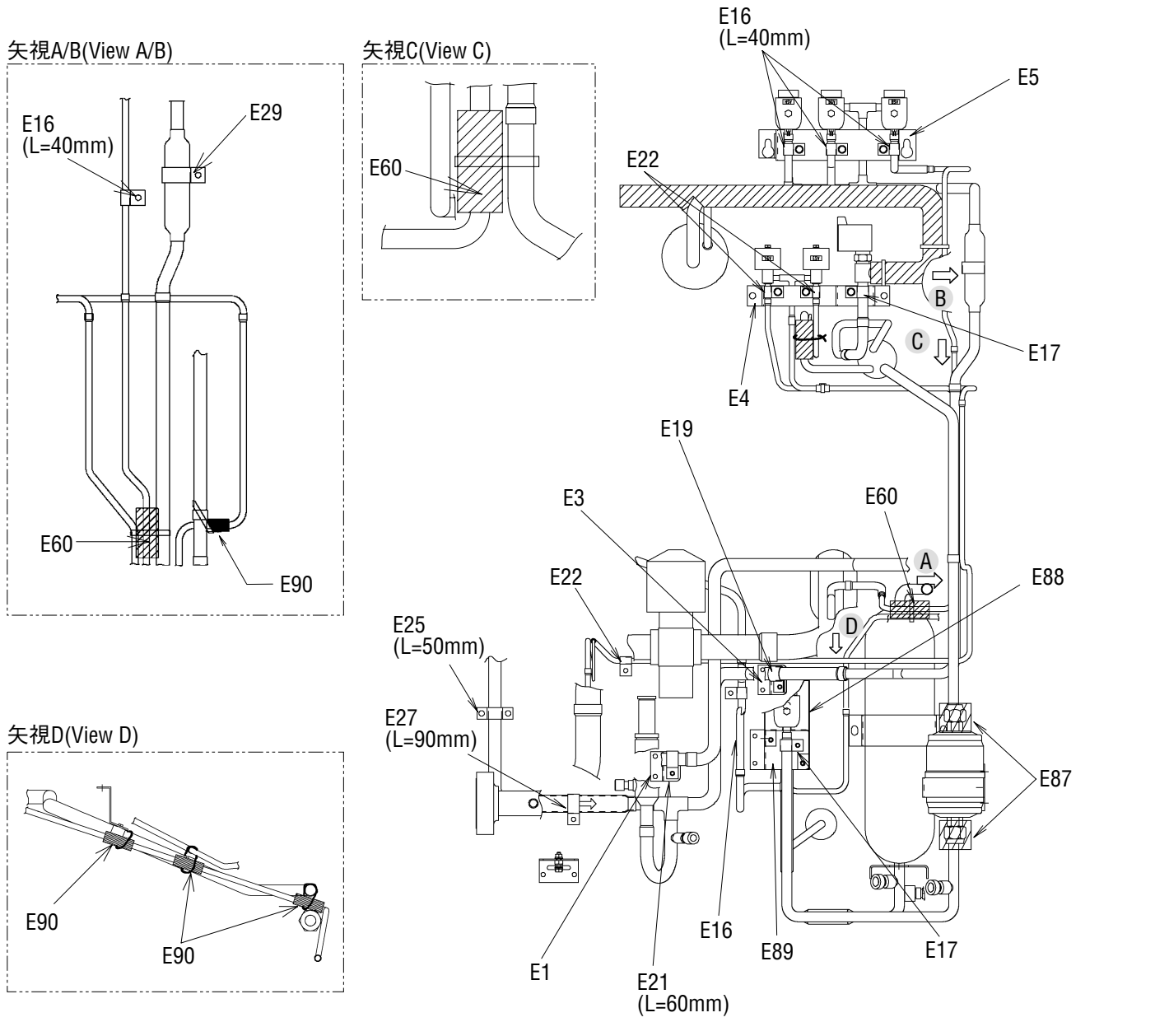

受液機器部詳細  
(Receive part detail)

ドライヤー部詳細  
(Dryer part detail)

圧力センサー配管部詳細  
(Pressure transducer detail)

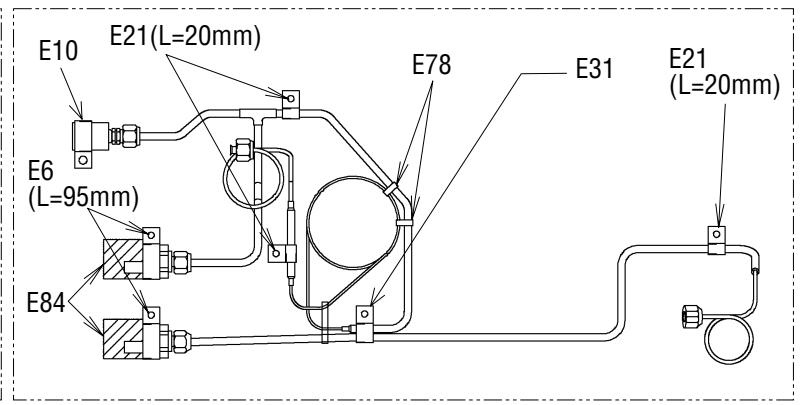
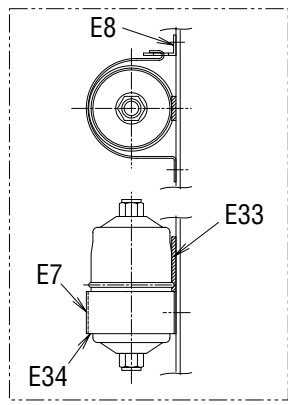
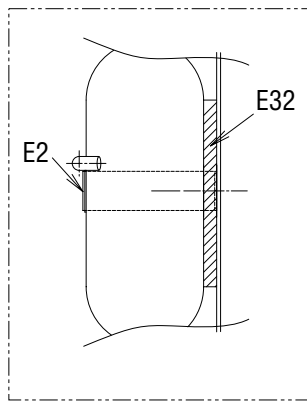

Other parts(Pipe clamp, sealing and insulation material etc.)  
 その他部品 (配管固定具、シール材、防熱材等)

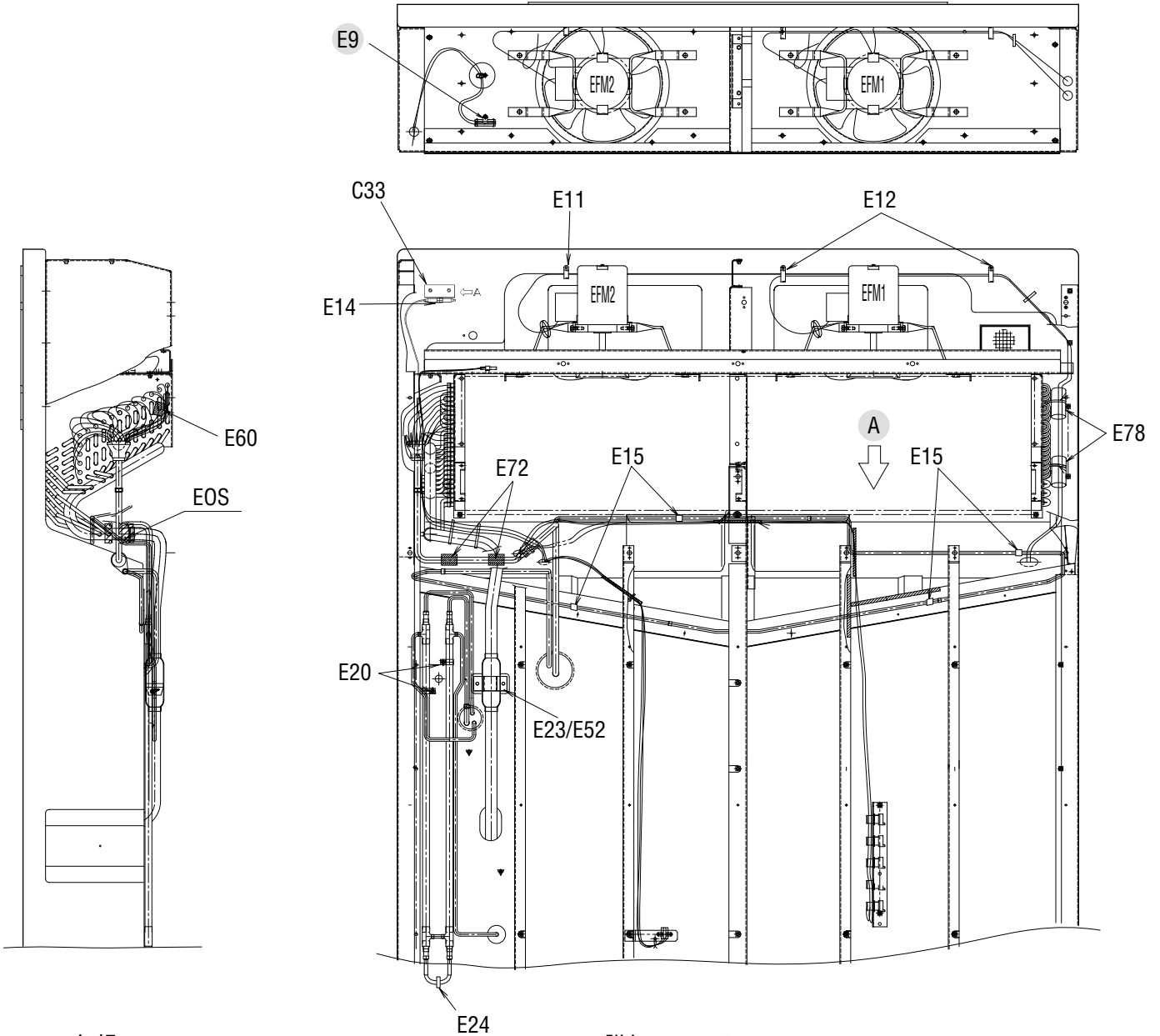

矢視A(VIEW A)

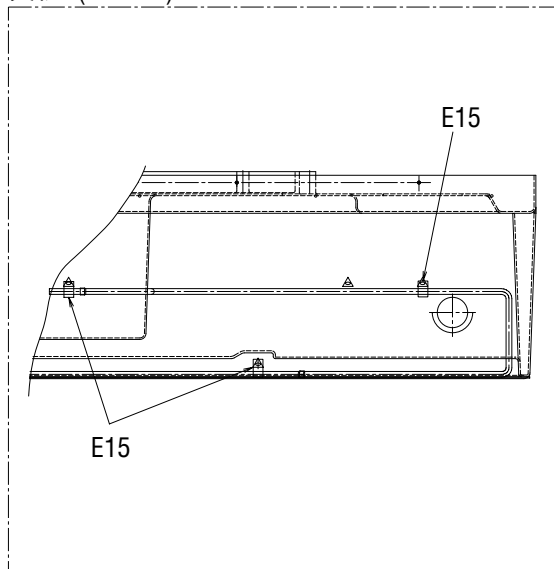

E9詳細(Detail of E9)

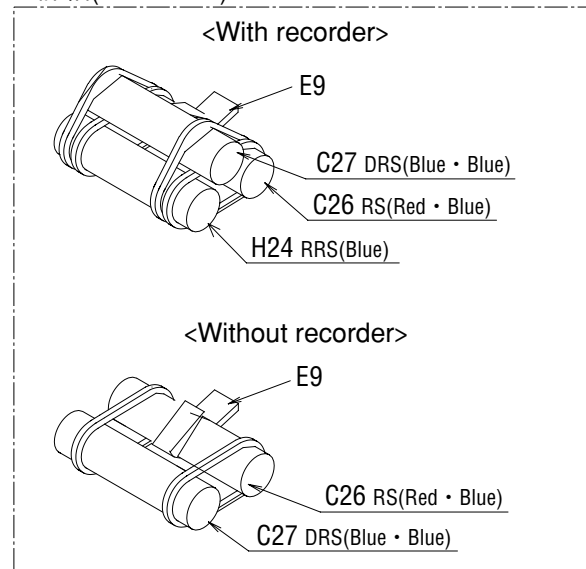

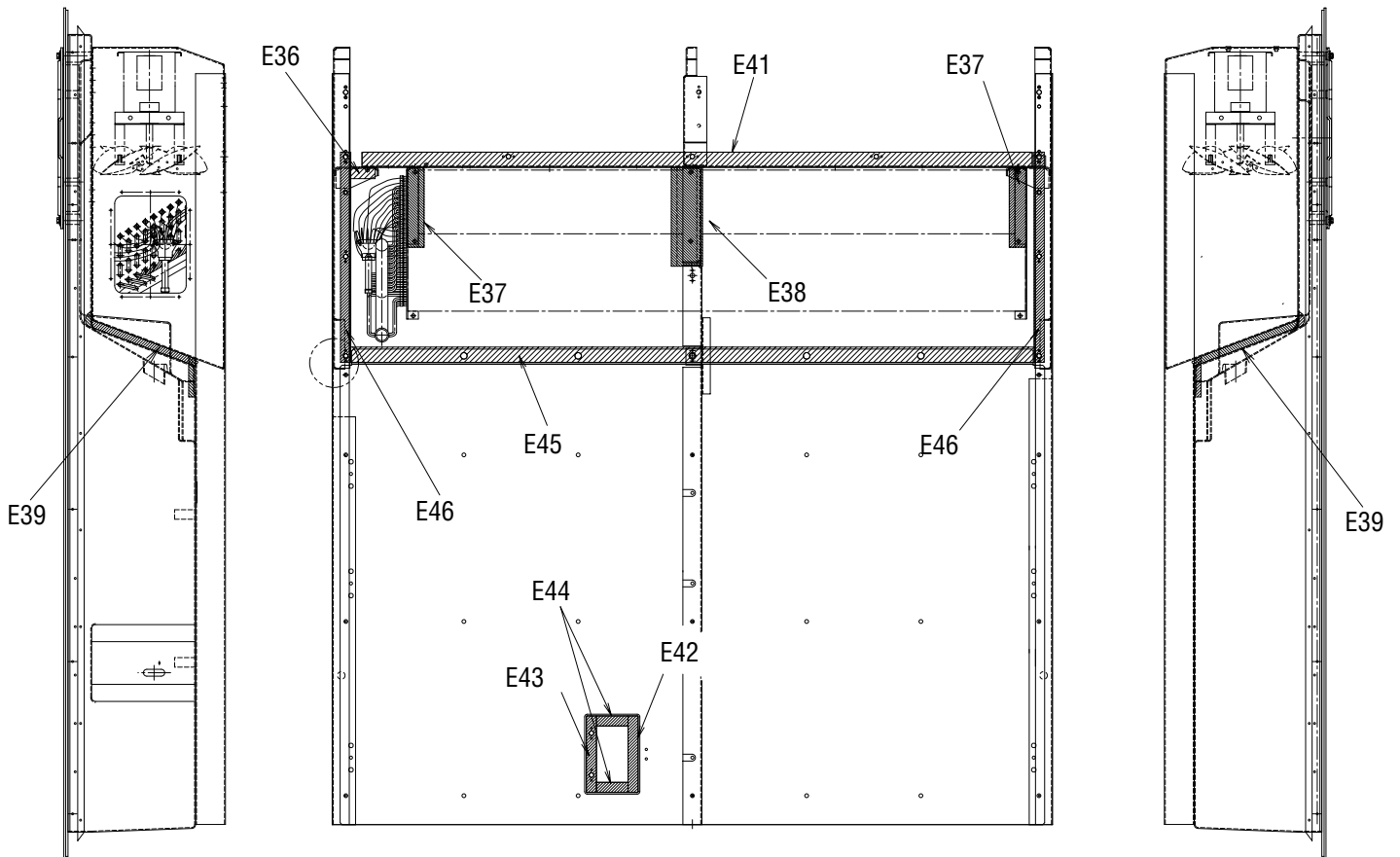
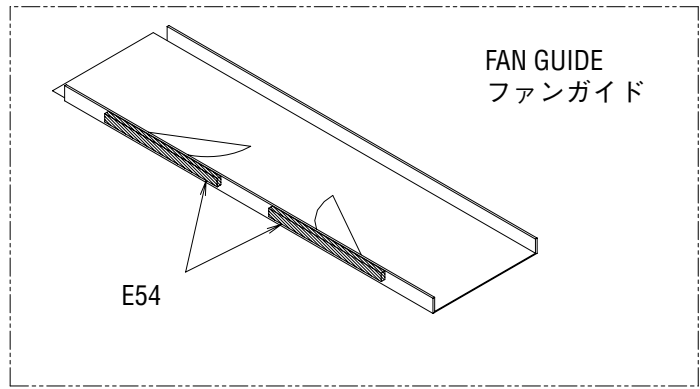

Other parts(Pipe clamp, sealing and insulation material etc.)  
その他部品 (配管固定具、シール材、防熱材等)

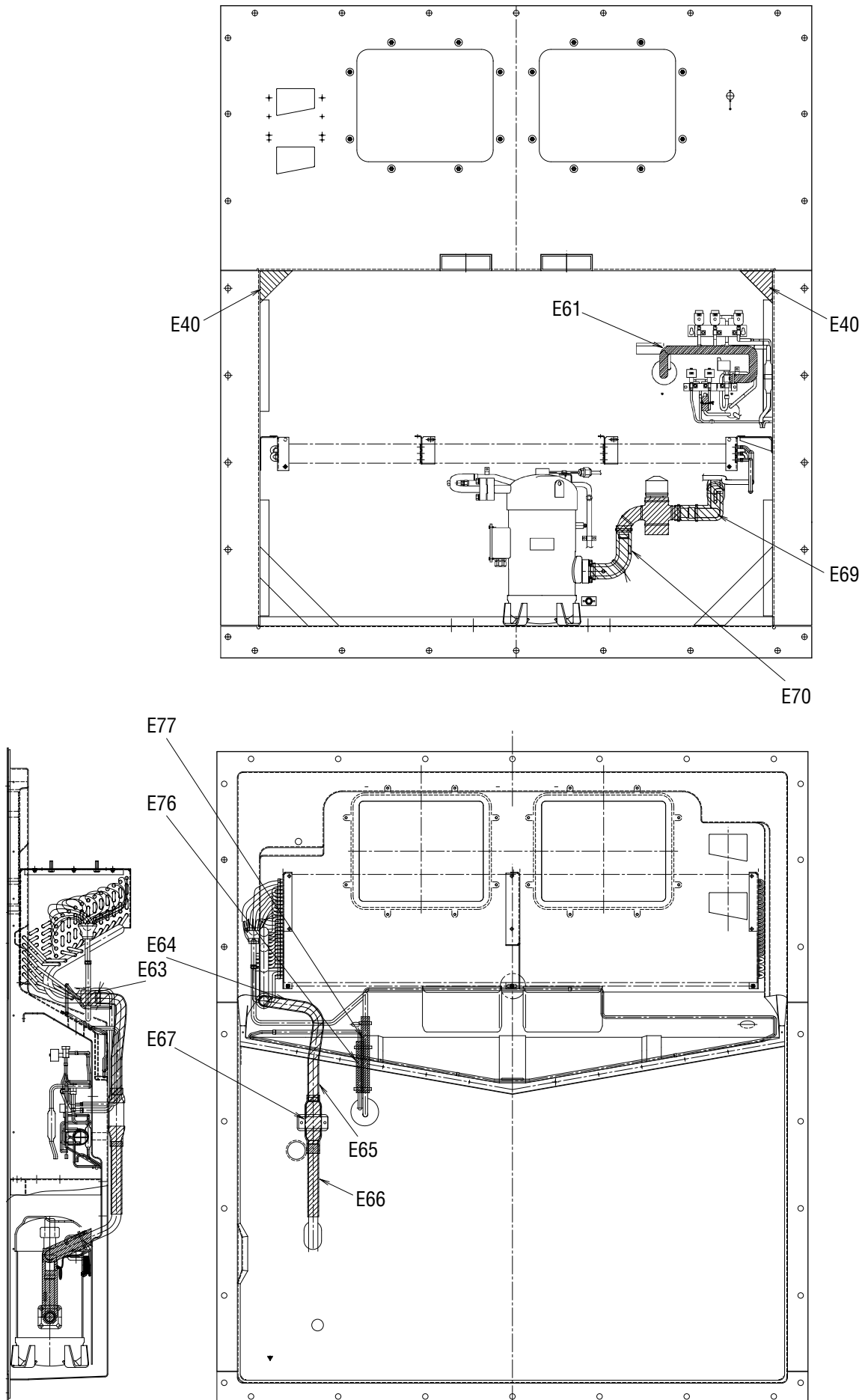

NO. 符号	INDEX	PARTS NO. 部品番号	PARTS NAME	部品名称	DWG. NO. 図面番号	TYPE SPECIFICATION 形式 仕様	QTY/UNIT		REMARKS 備考
							LXE10E-		
							A24R	A9R	
E1		1266694	Set plate, discharge pipe	吐出配管取付板	4P079462-1		1	1	Page41
E2		1266702	Fixture plate, receiver	レシーバー固定具	4P011318-2	t1.5	1	1	Page41
E3		1485938	Set plate, discharge pipe 2	吐出配管取付板 2	4P117351-1		1	1	Page41
E4		1485914	Set plate, ISV・ESV・EV solenoid valve	取付板 ( I S V ・ E S V ・ E V )	4P115765-1		1		Page41
E5		1549801	Set plate, HSV・DSV・BSV	取付板 ( H S V ・ D S V ・ B S V )	4P115767-1		1		Page41
E5			Mounting plate, (HSV, DSV, BSV)	取付板 ( HSV, DSV, BSV )	4P148770-1			1	Page41
E6		1270439	Tube clamp	管止め金	NE31016-61		2		Page41
E7		1266764	Fitting band, dryer	ドライヤー取付バンド	4PA51194-1		1	1	Page41
E8		1266771	Set plate, dryer	取付板 ( ドライヤ )	4P076788-1	t2.0	1	1	Page41
E9		0118273	Resin clamp	樹脂バンド	NE41015-2	MILK WHITE	4	4	Page42
E10		1222764	Resin clamp	樹脂バンド	NE41015-9	MILK WHITE	1	1	Page41
E11		0944528	Resin clamp	樹脂バンド	NE41015-7	MILK WHITE	2	2	Page42
E12		0142492	Resin clamp	樹脂バンド	NE41015-10	MILK WHITE	2	2	Page42
E13		1266788	Resin clamp	樹脂バンド	NE41015-12	MILK WHITE	4	4	Page40
E14		0702382	Tube clamp	管止め金	NE31016-52		1	1	Page42
E15		0782775	Tube clamp	管止め金	NE31016-51		5	5	Page40,42
E16		1584215	Nylon coating tube clamp	ナイロンコーティング管止め金	4P143802-51		4	4	Page41
E17		1584208	Nylon coating tube clamp	ナイロンコーティング管止め金	4P143802-52		2	2	Page41
E19		1584222	Nylon coating tube clamp	ナイロンコーティング管止め金	4P143802-54		1	1	Page41
E20		1386992	Double tube heat EXCH. Tube clamp	二重管熱交換管止め金	4P103281-56		2	2	Page42
E21		0016290	Tube clamp	管止め金	NE31016-56		1	1	Page41
E22		1584239	Nylon coating tube clamp	ナイロンコーティング管止め金	4P143802-71		6	6	Page41
E23		1266827	Fixing plate, filter	フィルタ固定具	4P071794-1	t1.5	1	1	Page42
E24		1386985	Double tube heat EXCH. Tube clamp	二重管熱交換管止め金	4P103281-51		1	1	Page42
E25		1266841	Tube clamp	管止め金 ( 2 )	4P005817-2		1	1	Page41
E27		1266858	Tube clamp	管止め金	NE31016-59		1	1	Page41
E29		1584246	Nylon coating tube clamp	ナイロンコーティング管止め金	4P143802-59		1	1	Page41
E30		537320	Hose band	ホースバンド	R4716528-3		2	2	Page38
E31		1380970	Hot gas tube clamp	ホットガス管止め金	4PA43040-1		1	1	Page41
E32		1266889	Cushion rubber, pipe clamp	緩衝ゴム ( 管止用 )	4P064896-1	t1.0	1	1	Page41
E33		1266896	Seal packing	シールパッキン	4P011314-1		1	1	Page41
E34		1270446	Dryer cushion rubber	ドライヤー緩衝ゴム	4PA53083-2		1	1	Page41
E35		1584253	Cushion rubber	緩衝ゴム	NE41013-3-300		1	1	
E36		1386947	Sealing material	蒸発器受枠 ( 1 ) シール材	4P090149-1		1	1	Page43
E37		1266935	Packing(for evaporator)	パッキン ( 蒸発器 )	4P063465-1		2	2	Page43
E38		1266942	Packing(for evaporator)	パッキン ( 蒸発器 )	4P063465-2		1	1	Page43
E39		1381036	Packing	パッキン	4P095033-1		2	2	Page43
E40		1177369	Cushion rubber	仕切用ゴム	4P026657-1	t2.0	2	2	Page44
E41		1386954	Sealing material	ファンガイドパッキン	3P090183-1		1	1	Page43
E42		1266973	Sealing material(patch plate2)	シール材 ( 当板 2 )	4P068964-1	t5.0	1	1	Page43

● When ordering the parts whose No. are not shown in the PARTS NO. column, be sure to describe DWG. NO..

● 部品番号欄が空白になっている部品は、図面番号で、指示願います。

Other parts(Pipe clamp, sealing and insulation material etc.)  
 その他部品 (配管固定具、シール材、防熱材等)

NO. 符号	INDEX	PARTS NO. 部品番号	PARTS NAME 部品名称	DWG. NO. 図面番号	TYPE SPECIFICATION 形式 仕様	QTY/UNIT		REMARKS 備考	
						LXE10E-			
						A24R	A9R		
E43		1381043	Sealing materialL(patch plate3)	シール材 (当板3)	4P095038-1		1	1	Page43
E44		1266997	Sealing material(patch plate1)	シール材 (当板1)	4P068968-1	t5.0	2	2	Page43
E45		1267008	Sealing packing	シールパッキン	3P011293-1		1	1	Page43
E46		1267015	Packing (side stay)	パッキン (サイドステー)	4P074127-1	BLACK	2	2	Page43
E52		1584260	Cushion rubber	緩衝ゴム	NE41013-4-230		1	1	Page42
E54		1267060	Packing for prevention of air bypass	バイパス防止用パッキン	4P011733-1		2	2	Page43
E55		1267077	Packing for prevention of vibration	C A 前板ビビリ防止パッキン	4P050050-1		2	2	Page28
E57		1267091	Wiring protection bush	配線保護ブッシュ	4P023920-1	BLACK	2	2	Page36
E60		1267123	Thermal insulation tube piping	断熱筒配管緩衝材	4P011309-1		5	5	Page40,41,42
E61		1549818	EV outside pipe insulation tube	膨張弁出口配管防露筒	3P121489-1		1		Page44
E61			EV outside pipe insulation tube	膨張弁出口配管防露筒	4P148629-2			1	Page44
E63		1267154	Insulation tube evaporater header	蒸発器ヘッダー防露筒	4P073525-1		1	1	Page44
E64		1267161	Cushion material suction pipe(1)	吸入配管緩衝材 (1)	3P073468-1		1	1	Page44
E65		1267178	Cushion material suction pipe(2)	吸入配管緩衝材 (2)	3P073468-2		1	1	Page44
E66		1267224	Cushion material suction pipe(3)	吸入配管緩衝材 (3)	3P073468-3		1	1	Page44
E67		1584378	Cushion material suction pipe	吸入配管断熱材	4P140007-1		1	1	Page44
E69		1267255	Thermal insulation tube	断熱筒 (吸入弁庫外側)	4P081186-1		1	1	Page44
E70		1267262	Thermal insulation tube	断熱筒 (圧縮機根元吸入弁)	4P081187-1		1	1	Page44
E72		1267286	Thermal insulation tube	断熱筒配管緩衝材	4P011309-3		1	1	Page42
E73		1267293	Thermal insulation tube	断熱筒配管緩衝材	4P011309-4		2	2	Page40
E74		1497056	Tube cushion material	配管緩衝材	4PA50421-2		1	1	
E76		1267325	Thermal insulation tube(drain outlet)	断熱筒 (ドレン入口管防露筒)	4P067126-1		1	1	Page44
E77		1485921	Thermal insulation tube	熱交入口管防露筒	4P117089-1		1	1	Page44
E78		1278921	Heat protection tie wrap	耐熱用タイラップ	4SA90202-1		8	8	Page41,42
E79		0024640	Rubber bush	ゴムブッシュ	R3713279-3		5	5	Page40
E80		1267356	Rubber bush	ゴムブッシュ	R3713279-4		1	1	Page40
E82		1267370	Rubber bush	ゴムブッシュ	R3713279-2		2	2	Page40
E83		1267387	U-packing	UP字形パッキン	NA40014-4-500	L=500	1	1	Page40
E84	B	1605509	Heat shrinkable tube	熱収縮チューブ	4P151322-1		2	2	Page41
E85	B	1267402	Heat shrinkable tube	熱収縮チューブ	4P074613-1	BLACK I.D. φ26.1,t0.4	1	1	Page40
E86	B	1270453	Heat shrinkable tube	熱収縮チューブ	4P075241-1		1	1	
E87	B	1497070	Thermal insulation tape, no-dry	不乾性形断熱テープ	3SA90101-3-KA		3	3	Page41
E88		1494925	LSV cover	液電磁弁カバー	4P093386-1		1	1	Page41
E89		1270484	Mounting plate, solenoid valve	取付板	4P082208-1		1	1	Page40,41
E90		1381012	Protection bush	保護ゴム	4PA43128-1		3	3	Page41

● When ordering the parts whose No. are not shown in the PARTS NO. column, be sure to describe DWG. NO..

● 部品番号欄が空白になっている部品は、図面番号で、指示願います。

NO. 符号	INDEX	PARTS NO. 部品番号	PARTS NAME	部品名称	DWG. NO. 図面番号	TYPE SPECIFICATION 形式 仕様	QTY/UNIT		REMARKS 備考
							LXE10E-		
							A24R	A9R	



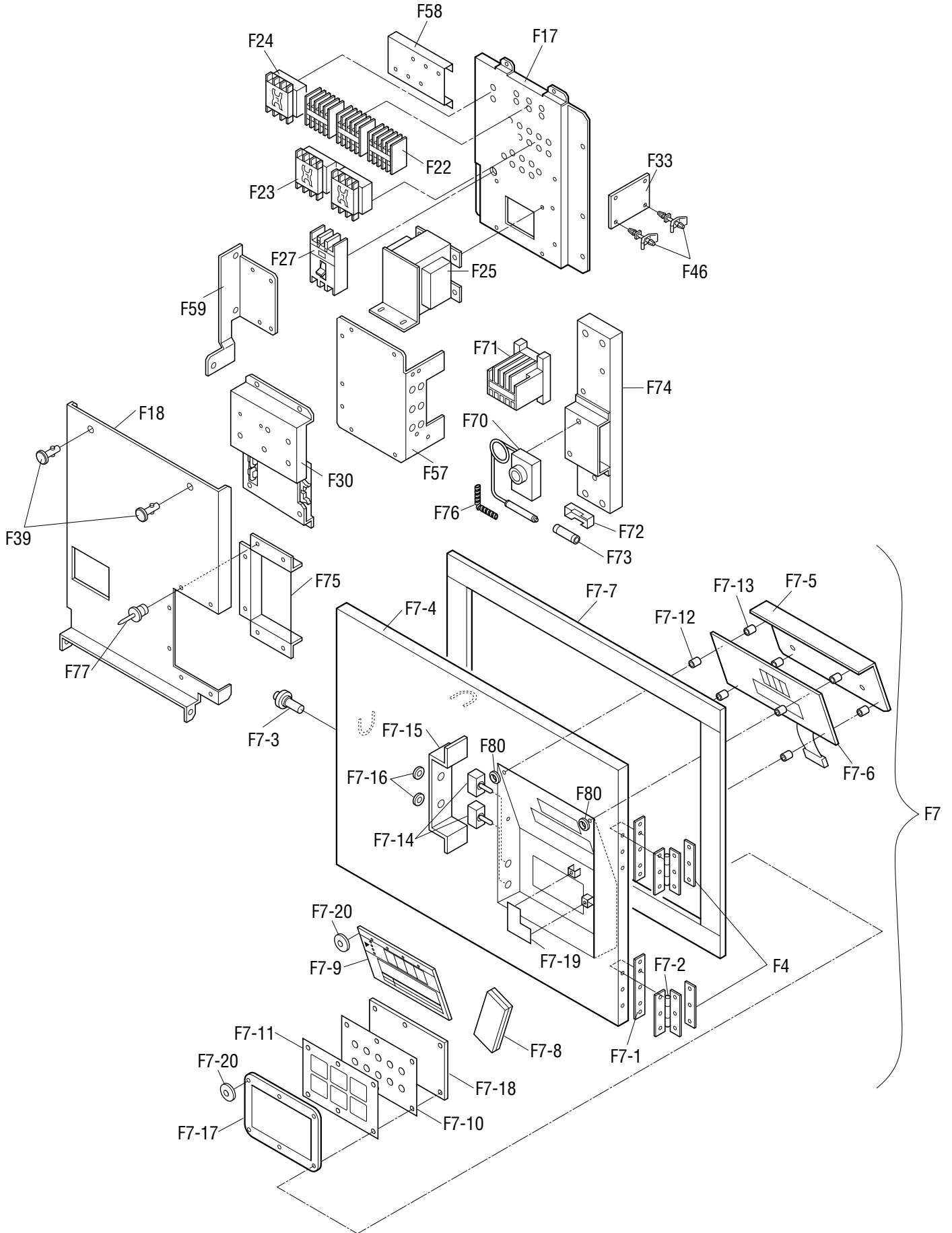

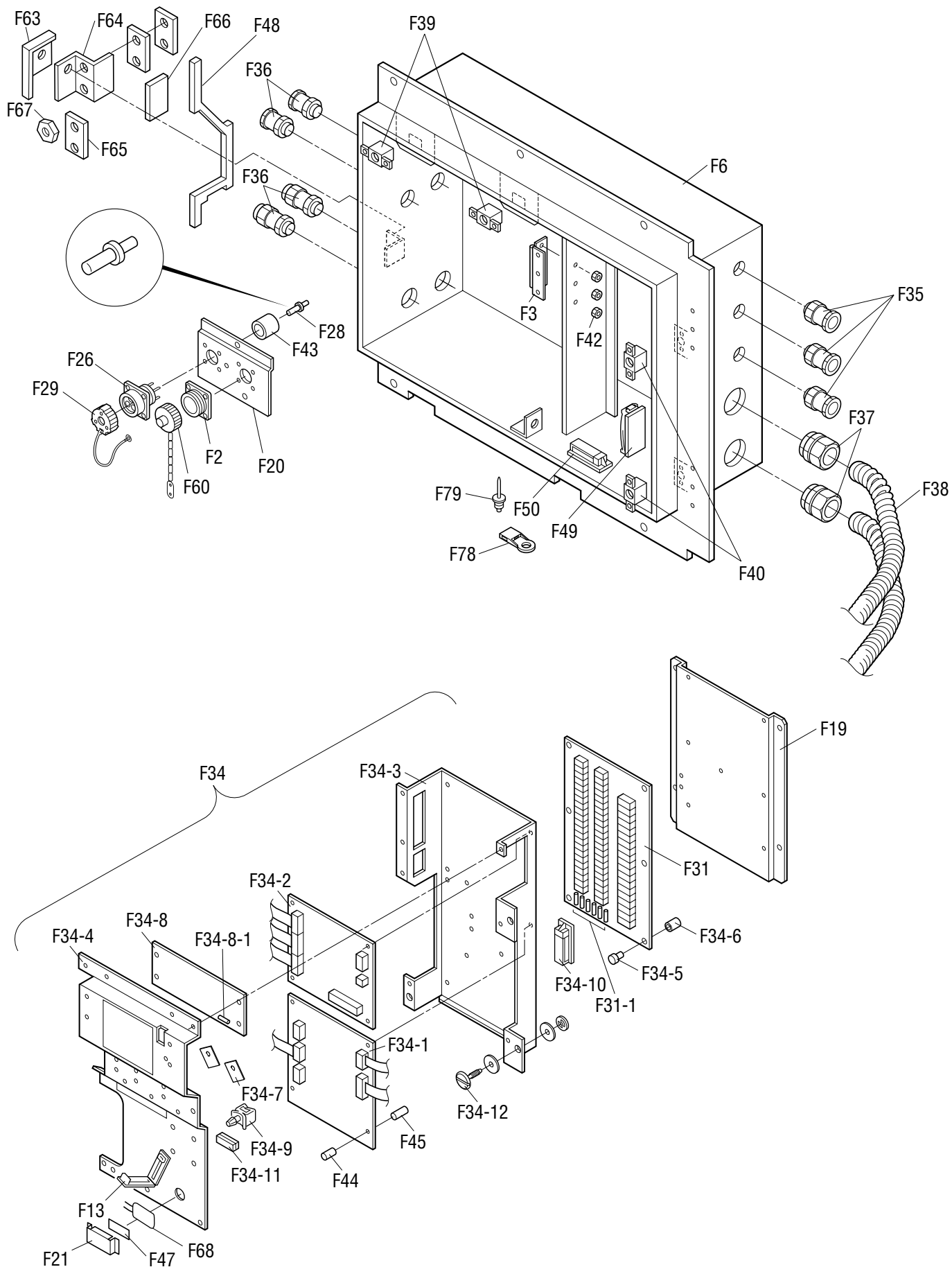

NO. 符号	INDEX	PARTS NO. 部品番号	PARTS NAME	部品名称	DWG. NO. 図面番号	TYPE SPECIFICATION 形式 仕様	QTY/UNIT		REMARKS 備考
							LXE10E-		
							A24R	A9R	
F1		844022	Plain washer	平座金	4SK07005-12		4	4	
F2	B	1549849	Wire harness ass'y	ワイヤハーネス組立品(モニタリングレセプタクルケーブル)	4P121213-1-KA		1	1	
F3		1136407	Hinge(recorder/box cover)	平蝶番 (レコーダボックス蓋)	4P021346-1		1	1	
F4		1136414	Patch plate nut	当板ナット	4P044898-2		2	2	
F6			Control box welding ass'y	C. BOX溶接組立品	2P144892-1		1	1	
F7	C		Control box cover ass'y	コントロールボックス蓋組立品	2P143216-1		1	1	
F7-1		1136414	Patch plate nut	当板ナット	4P044898-2		2	2	
F7-2		1136407	Hinge(recorder/box cover)	平蝶番 (レコーダボックス蓋)	4P021346-1		2	2	
F7-3		0907093	Roller, quick lock lever	ワンタッチ金具用ローラ	4PA51277-1		1	1	
F7-4			Control box cover welding ass'y	コントロールボックス蓋溶接組立品	3P143217-1		1	1	Refer to Page68
F7-5		1497171	Operation display cover	操作表示カバー	3P111696-1		1	1	
F7-6	A	1010815	Display board	表示基板	2P010368-2		1	1	
F7-7		1381081	Rubber gasket	ゴムガスケット (C. BOX蓋用パッキン)	4P085198-1		1	1	Refer to Page68
F7-8		1136539	FCW clamp	FCWクランプ	4P015574-2		1	1	
F7-9		1267464	Display name plate	表示銘板	2P072710-1		1	1	
F7-10	A	1063509	Switch	スイッチ	2P030937-1		1	1	
F7-11	B		Name plate, operation(MODE key)	操作銘板 (モードキー)	2P089567-1		1	1	
F7-12		1497195	Spacer(1)	スペーサ (1)	4P111965-1		4	4	
F7-13		1497203	Spacer(2)	スペーサ (2)	4P111965-2		4	4	
F7-14		0038656	Switch	スイッチ	3PA19979-1		2	2	
F7-15			Switch cover	スイッチカバー	4P143223-1		1	1	
F7-16		384102	Rubber bush	ゴムブッシュ	NA30011-43		2	2	
F7-17		1140134	Gasket, sheet key	シートキーパッキン	4P010875-1		1	1	
F7-18			Fixing-plate, sheet key	シートキー取付板	4P143224-1		1	1	
F7-19			Switch cover	スイッチカバー	4P143273-1		1	1	
F13		1136539	Clamp	クランプ金具	4P015574-2		1	1	
F17		1387197	Set plate(1)	機器取付板 (1)	2P095432-1		1	1	
F18		1267503	Cover(1)	機器カバー (1)	2P143227-1		1	1	
F19		1549870	Mounting plate	端子台基板取付板	3P092019-1		1	1	
F20		1612639	Fixing plate, PC port	パソコンポート固定板	3P147872-1		1	1	
F21		1241138	Fixing plate, battery	固定板 (電池)	4P010920-1		1	1	
F22	A	1198931	Magnetic contactor(for Fans)	電磁接触器 (ファン用)	3P055568-1	24V PAK-6J31C	3	3	
F23	A	1241493	Magnetic contactor(Phase correction contactor)	相順切換電磁接触器 (PCC)	3P071508-3	24V RSK-35J	1	1	
F24	A	1198917	Magnetic contactor(Compressor)	電磁接触器 (圧縮機)	3P055566-1	24V PAK35J-S536	1	1	
F25	C	1562796	Low frequency transformer	低周波変圧器	3P139293-1		1	1	
F26	C	0991531	PC port connector	パソコンポートコネクタ	3P010803-1		1	1	
F27	A	1381120	Earth leakage circuit breaker	漏電遮断器	3P093326-1		1	1	
F28	C	1141144	Contact, receptacle	コンタクト、レセプタクル用	3P010806-1	HD10	3	3	
F29		1267541	Cover ass'y, PC port	パソコンポートカバー組立品	3P010743-1		1	1	
F30	A	0954633	PT/CT board	P T / C T ボード	2P010906-3		1	1	

● When ordering the parts whose No. are not shown in the PARTS NO. column, be sure to describe DWG. NO..

● 部品番号欄が空白になっている部品は、図面番号で、指示願います。

NO. 符号	INDEX	PARTS NO. 部品番号	PARTS NAME	部品名称	DWG. NO. 図面番号	TYPE SPECIFICATION 形式 仕様	QTY/UNIT		REMARKS 備考
							LXE10E-		
							A24R	A9R	
F31	A	1256116	Terminal strip boaed	端子台基板	2P078284-1		1	1	
F31-1	A	0030652	Fuse, controller	制御用ヒューズ	4SA42006-4	250V 10A	6	6	
F33	A	0329679	Reverse phase protector	逆相保護装置 (R P P)	3SA42153-1	346-440V	1	1	
F34	A	1562804	Controller assemblies	コントローラ組立品	3P065573-17		1	1	
F34-1	A	1562811	PCB ass'y	プリント基板組立品	2P065387-15		1	1	
F34-2	A	0954594	I/O board	I/O ボード	2P010367-1		1	1	
F34-3		1267558	Bottom plate, contoller	コントローラ底板	2P049529-2	t1.2	1	1	
F34-4	B	1295584	Controller cover	蓋 (コントローラ)	2P085424-1	t1.2	1	1	
F34-5		1099940	Support bushing, PCB	プリント基板サポートブッシュ	MI49531-11		14	14	
F34-6		1099957	Support color, PCB	プリント基板サポートカラー	MI49531-13		14	14	
F34-7		1267572	Rubber transistor	放熱用ゴムトランジスタ	4P005330-1		2	2	
F34-8	A	1250783	PC board for suction modulating valve	プリント基板組立品(吸入制御弁用)	3P065441-1	EC0058	1	1	
F34-8-1	A	670223	Fuse, controller	制御用ヒューズ	4SA42006-3	250V 5A	1	1	
F34-9		1267596	Locking wire saddle	ロッキングワイヤサドル	4P015570-2	LWS	3	3	
F34-10		1267604	Flat cable clamp	フラットケーブルクランプスナップタイプ	4P015573-1		1	1	
F34-11		1136539	Clamp	クランプ金具	4P015574-2		1	1	
F34-12		1267611	Speed bolt	スピードボルト (M6)	4P048680-3	M6X20(S)	2	2	
F35		1267628	Wire(wire ground)	電線 (電線グラウンド)	4P067662-1		2	2	
F36		1267635	Wire(wire ground)	電線 (電線グラウンド)	4P067663-1		4	4	
F37		1267642	Flexible tube connector	フレキシブル管用コネクタ	4P010926-6		2	2	
F38		1267659	Flexible wire tube	フレキシブル電線管	3P010927-62		2	2	
F39		1267666	Quick fastener	クイックファスナー	4P064642-1		2	2	
F40		860015	Universal nut	自在ナット	R4713188-1		9	9	
F42		833302	Nylon nut	ナイロンナット	R4716460-1	M4	3	3	
F44		1099940	Support bushing, PCB	プリント基板サポートブッシュ	MI49531-11		7	7	
F45		1099957	Support color, PCB	プリント基板サポートカラー	MI49531-13		7	7	
F46		981616	Locking card spacer	ロッキングカードスペーサー	R3428091-3	KGLS-8S	4	4	
F47		1267697	Cushion rubber	緩衝ゴム電池用	4P015624-1		1	1	
F48		1326820	Packing(C.BOX front plate)	パッキン (C. BOX 前板)	4P085513-1		1	1	
F49		1136539	Clamp	クランプ金具	4P015574-2		2	2	
F50		1267712	Clamp	クランプ金具	3P049495-1		1	1	
F57		1549894	Sset plate(PT/CT board)	機器取付板 (P T / C T ボード)	3P126713-1		1	1	
F58		1267781	Mounting plate, elect components	電装品取付板	4P064227-1	t=1.2	1	1	
F59		1549902	Sset plate(breaker)	機器取付板 (ブレーカ)	3P126712-1		1	1	
F60	C	1549919	Cap	キャップ	4P121213-1-KI		1	1	
F63		1295630	Lever	ワンタッチ金具	4P085171-1		1	1	
F64		1295647	Fixing plate for lever	ワンタッチ金具取付板	4P085164-1		1	1	
F65		0907125	Sealed sheet	絶縁シート (ワンタッチ金具)	4PA52417-1	t0.075±0.01	1	1	
F66		0907132	Sealed sheet	絶縁シート (ワンタッチ金具)	4PA52417-2	t0.075±0.01	1	1	
F67		833301	Nut	ナイロンナット	R4716460-3	M6	3	3	





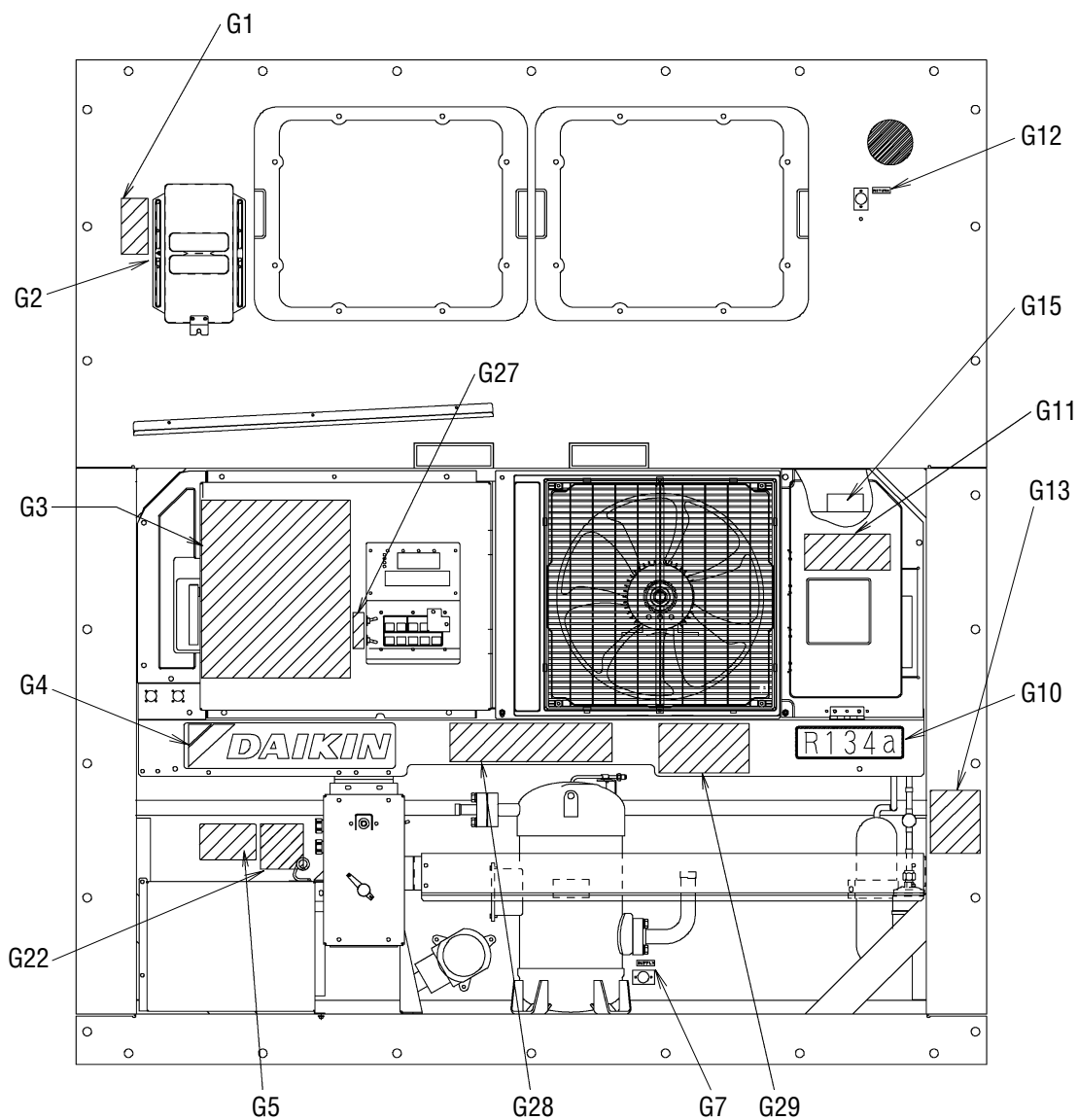

電源切替ボックス (Power changeover box)

コントロールボックス内部 (Inside of Control Box)

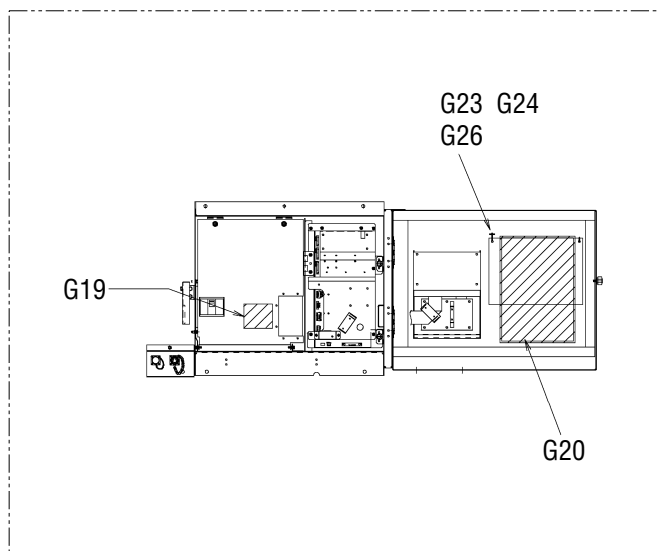
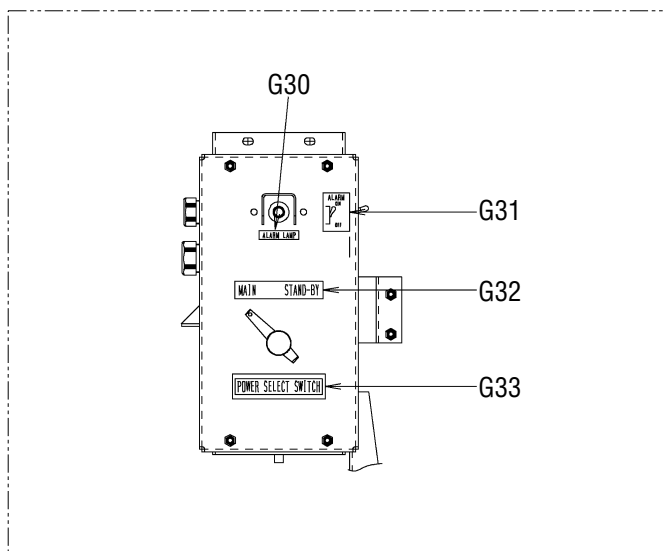





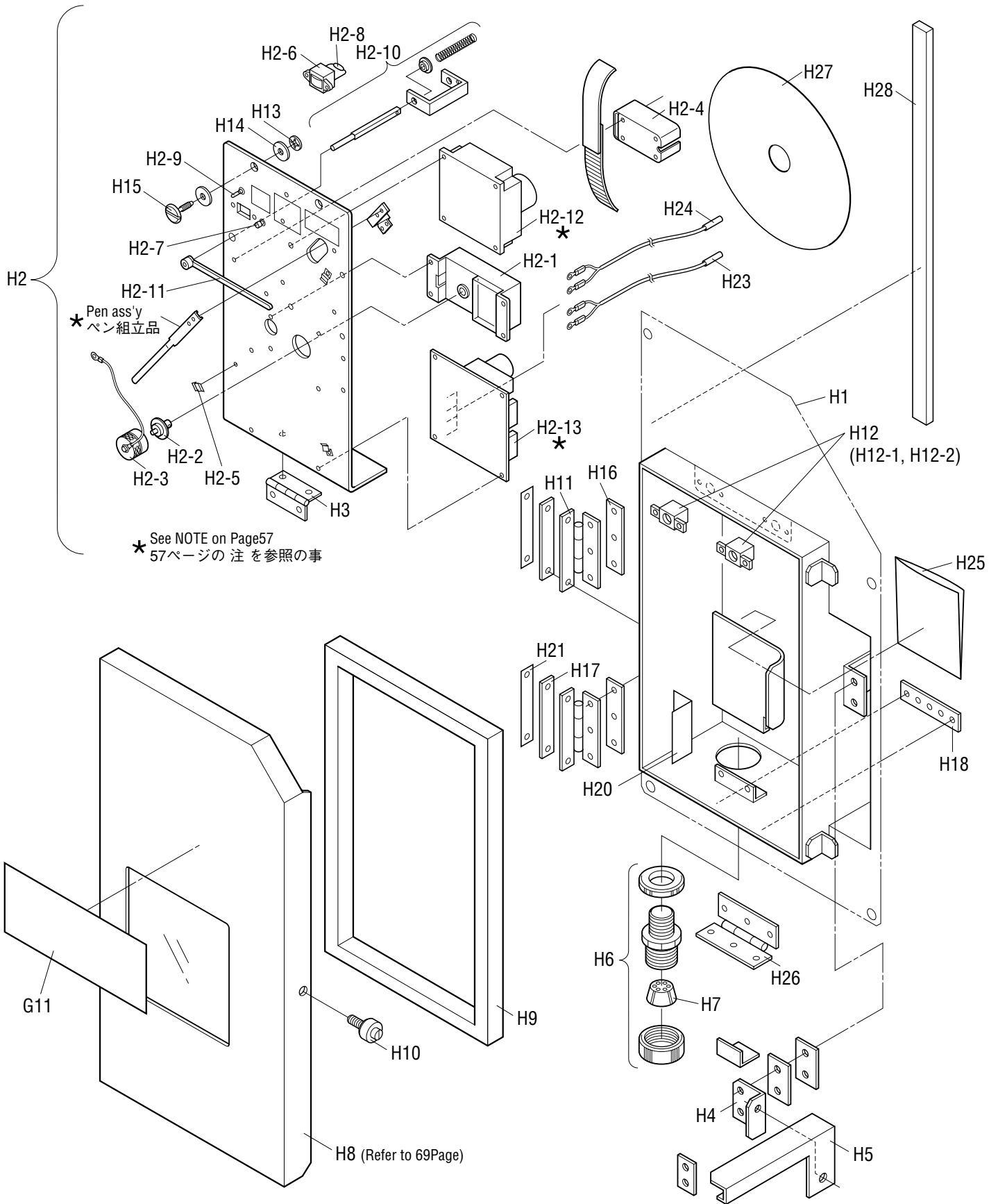

NO. 符号	INDEX	PARTS NO. 部品番号	PARTS NAME	部品名称	DWG. NO. 図面番号	TYPE SPECIFICATION 形式 仕様	QTY/UNIT		REMARKS 備考
							LXE10E-		
							A24R	A9R	
H1		1587726	Recorder box ass'y for welding	レコーダ B O X 溶接組立図	2P048643-8		1	1	
H2		1267820	Temperature recorder	温度記録計	2P021722-10		1	1	
H2-1	B	0143495	Quartz motor	クォーツ時計	3PA20194-2		1	1	
H2-2	B		Shaft, chart	チャート軸受け		4-E4191P1 BS	1	1	
H2-3		0037855	Chart stopper ass'y	チャート押さえ組立	4PA20211-1	A5052BP	1	1	
H2-4			Battery holder	電池ホルダー		4-E4374C1 ABS樹脂6Z680	1	1	
H2-5			Holder	ホルダー		RH14	3	3	
H2-6	B		Indicator	メーター		4-E6827P1 MODEL250	(1)	(1)	
H2-7	B		Push button switch	押しボタンスイッチ		4-E4777C1	(1)	(1)	
H2-8	B		Resistor	抵抗		TS60E-B3.9K	(1)	(1)	
H2-9	B		Toggle switch	トグルスイッチ		M2018G	(1)	(1)	
H2-10			Stopper	ストッパー		4-E4752C1	1	1	
H2-11	C		Lever	レバー		4-E4161C1 SUS27	1	1	
H2-12	B		Servo unit	サーボユニット		3-C5575C3	1	1	
H2-13	B		PC board ass'y	プリント基板組立品		3-C7505C1	1	1	
<p>Note: The recording-pen assembly, H2-12 servo-unit and H2-13 PCB assembly have been adjusted in the factory as one set. Accordingly, individual assembly can not be adjusted separately. When any component in those assembly should faulty, replace the entire H2 temperature recorder as a set.</p> <p>注：ペン組立品、H2-12(サーボユニット)及びH2-13(プリント基板組立品)は、一体で工場にて調整されています。従って、現地での単体での調整は不可能です。この部品が不具合の場合は、H2の温度記録計一式で交換してください。</p>									
H3		1136104	Hinge	平蝶番	4P043349-1		1	1	
H4		1267837	Mounting plate, quick lock lever	ワンタッチ金具取付板	4P067761-1		1	1	
H5		1136111	Quick lock lever	ワンタッチ金具	4P043377-1		1	1	
H6		0773771	Cable gland	電線グラッド	3PA37599-10	SCL-22B	1	1	
H7		1267844	Grand rubber bush	グラッドゴムブッシュ	4P032156-1		1	1	
H8		1587656	Cover(recorder)	蓋 (レコーダ)	1P054302-4		1	1	Refer to Page69
H9		1267868	Packing (recorder cover)	パッキン (蓋)	4P063866-1		1	1	Refer to Page69
H10		1267875	Roller	ワンタッチ金具用ローラ	3P054321-1		1	1	
H11		1136096	Hinge, cover	蓋締付蝶番	4P043069-1		2	2	
H12		860015	Universal nut	自在ナット	R4713188-1		2	2	
H12-1			Body	本体	R4713188-1-KA		2	2	
H12-2			Plate nut	プレートナット	R4713188-1-KI		2	2	
H13		840002	Drop out prevention washer	脱落防止座金	R4718607-6		2	2	
H14		860005	Washer, speed bolt	スピードボルト用座金	R4713334		4	4	
H15		1267611	Speed bolt	スピードボルト (M6)	4P048680-3	M6X20(S)	2	2	
H16		874014	Patch plate nut	当板ナット	R3715992-33		2	2	
H17		1267899	Patch plate nut	当板ナット	4P066242-1		2	2	
H18		1136414	Patch plate nut	当板ナット	4P044898-2		1	1	
H20		1267907	Sealing material	シール材	4P049613-1		1	1	
H21		1267914	Insulation sheet	絶縁シート	4P066250-1	t0.075±0.01	2	2	
H23		0798307	Sensor (RSS)	センサー (RSS)	3PA61769-4	ST9503-4 (Green, Green)	1	1	Refer to Page72

● When ordering the parts whose No. are not shown in the PARTS NO. column, be sure to describe DWG. NO..

● 部品番号欄が空白になっている部品は、図面番号で、指示願います。

**Parts related with option 1 – Recorder box**  
**オプション関連部品1 – レコーダボックス**

NO. 符号	INDEX	PARTS NO. 部品番号	PARTS NAME 部品名称	DWG. NO. 図面番号	TYPE SPECIFICATION 形式 仕様	QTY/UNIT		REMARKS 備考	
						LXE10E-			
						A24R	A9R		
H24		0798282	Sensor (RRS)	センサー (R R S)	3PA61769-2	ST9503-2 (Blue, Blue)	1	1	Refer to Page72
H25		1267921	Protection sheet, recording chart	保護シート	4P015666-1		1	1	
H26	C	1136407	Hinge(recorder/box cover)	平蝶番 (レコーダボックス蓋)	4P021346-1		1	1	
H27		0581213	Recording chart	記録紙	3PA43798-1		3	3	
H28		1267907	Sealing material	シール材	4P049613-1		1	1	
G11			Recorder box Name plate	レコーダボックス銘板(英・和)	3P116519-1		1	1	Refer to Page69

● When ordering the parts whose No. are not shown in the PARTS NO. column, be sure to describe DWG. NO.. ● 部品番号欄が空白になっている部品は、図面番号で、指示願います。

NO. 符号	INDEX	PARTS NO. 部品番号	PARTS NAME	部品名称	DWG. NO. 図面番号	TYPE SPECIFICATION 形式 仕様	QTY/UNIT		REMARKS 備考
							LXE10E-		
							A24R	A9R	

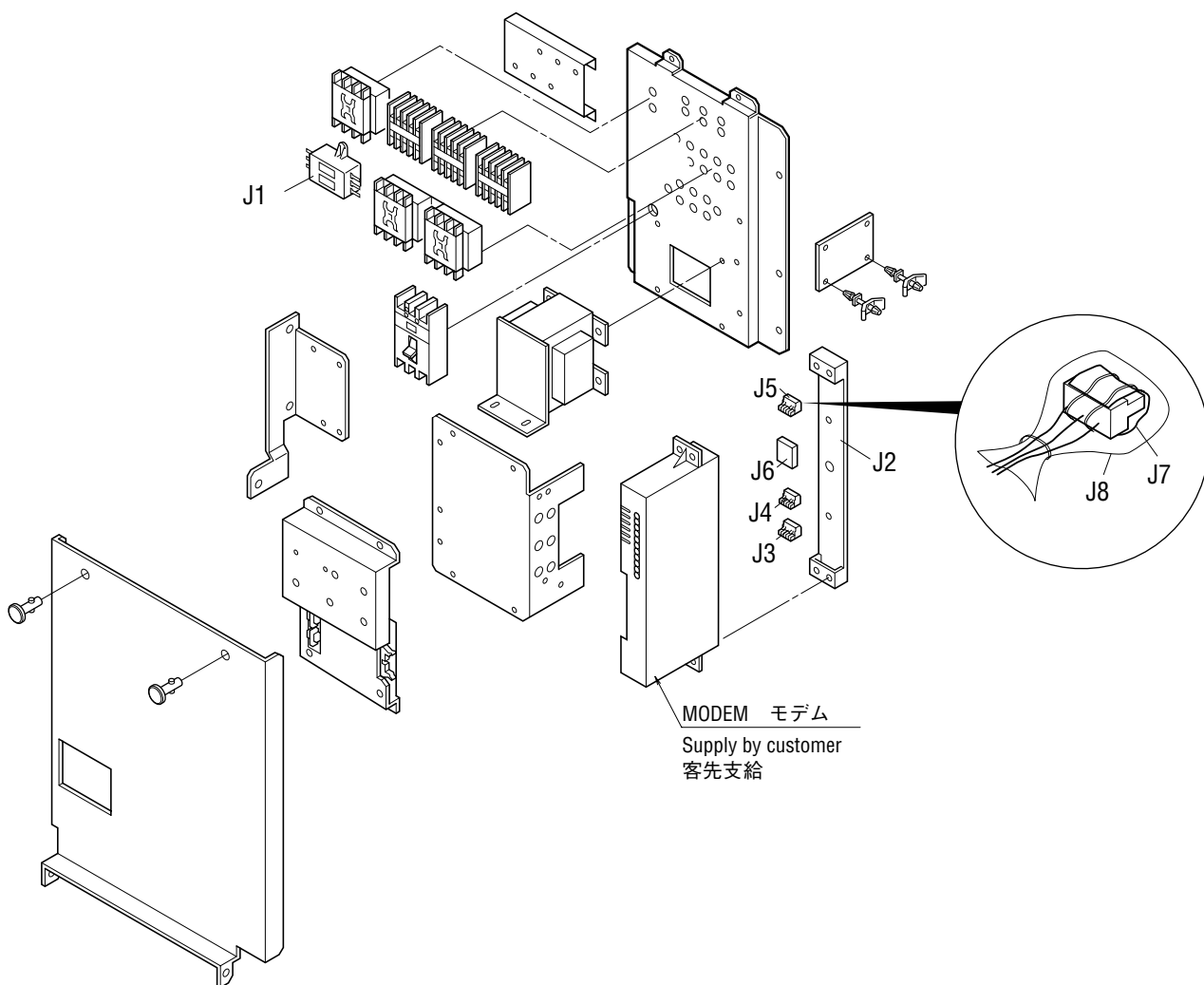

NO. 符号	INDEX	PARTS NO. 部品番号	PARTS NAME	部品名称	DWG. NO. 図面番号	TYPE SPECIFICATION 形式 仕様	QTY/UNIT		REMARKS 備考
							LXE10E-		
							A24R	A9R	
J1	B	0954640	Noise filter	ノイズフィルタ	2PA51273-1	ZAC2206-11	1	1	
J2		1448410	Mounting plate(modem)	取付板 (モデム)	4P081133-1		1	1	
J3		1267736	Connector for MODEM	モデム用コネクタ	3P012038-3	BLA3	1	1	
J4		1267743	Connector for MODEM	モデム用コネクタ	3P010371-7		1	1	
J5		1267750	Connector for MODEM	モデム用コネクタ	3P012038-7	BLA7	1	1	
J6		0468839	Noise filter(for modem)	ノイズフィルター (モデム用)	3EA76001-1		1	1	
J7		1267767	CR rubber	C R ゴム	4P027629-1		1	1	
J8		1344781	Vinyl bag	ビニール袋	RI40021-5		2	2	

1. Indoor fan guard

1. 庫内ファンガード

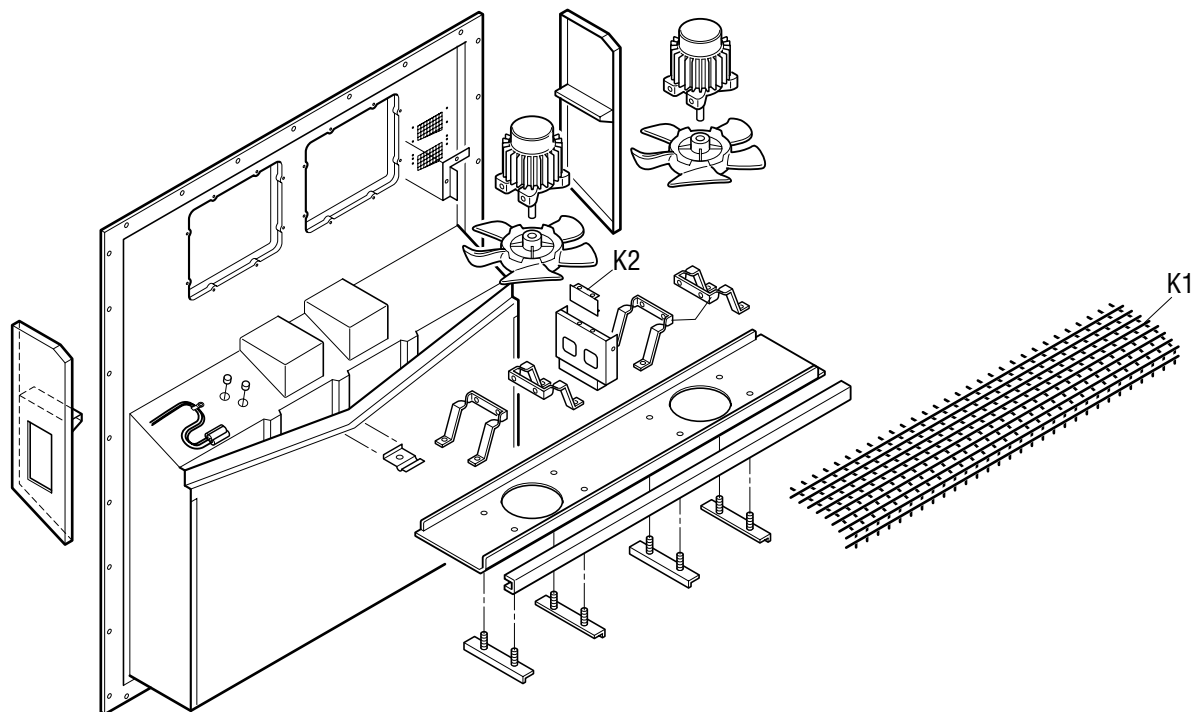

2. Evaporator coil

2. 蒸発器コイル組立品

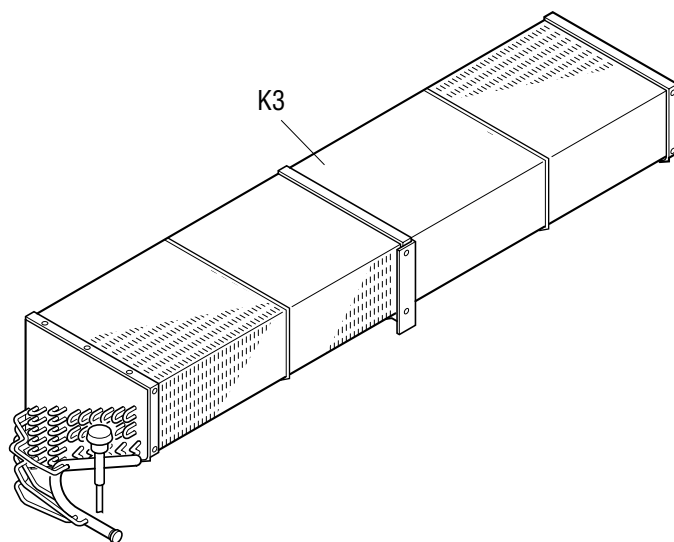





Parts related with option 4 – Power changeover switch box relating  
オプション関連部品 4 – 電源切替スイッチボックス関連

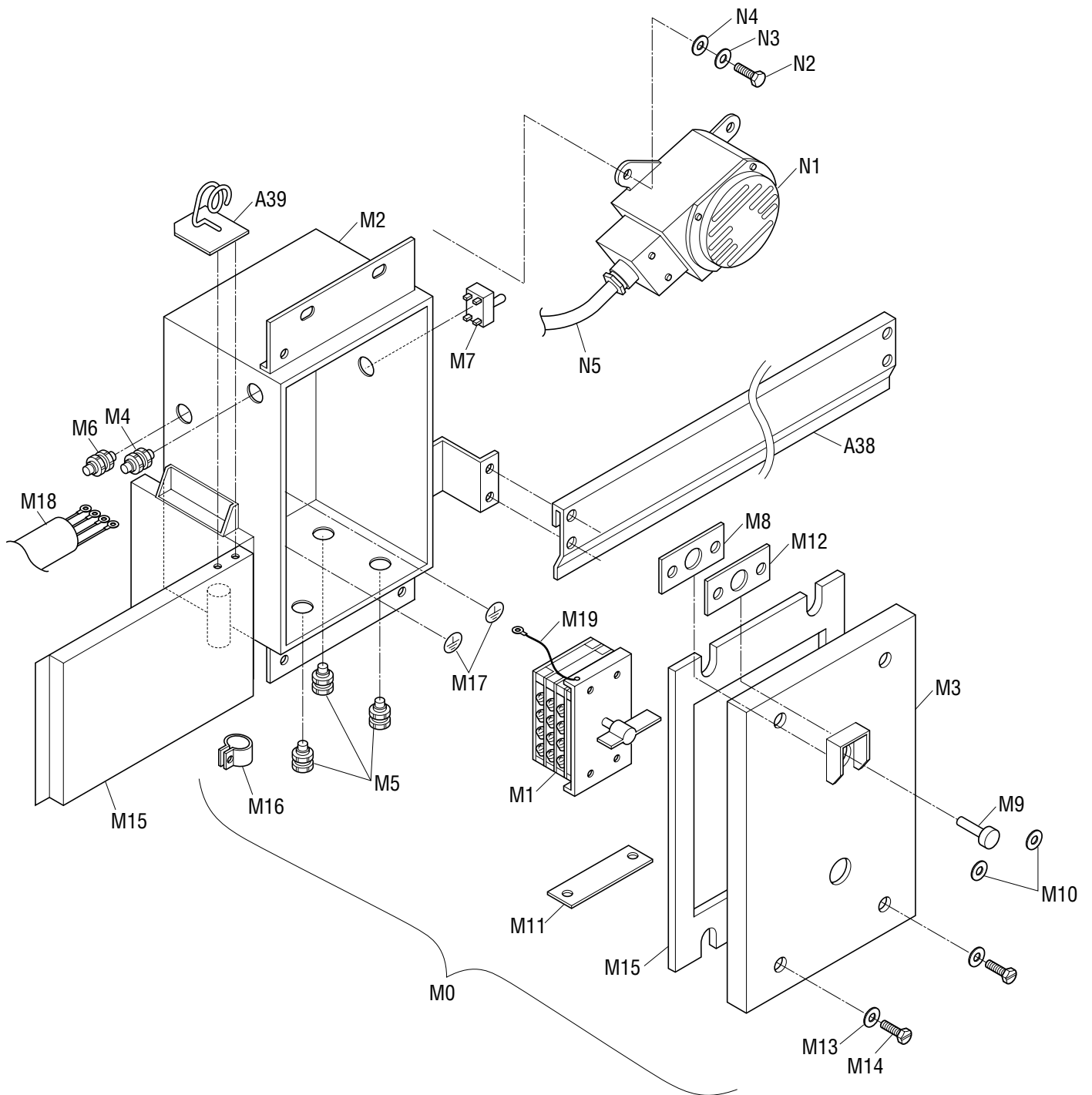

NO. 符号	INDEX	PARTS NO. 部品番号	PARTS NAME	部品名称	DWG. NO. 図面番号	TYPE SPECIFICATION 形式 仕様	QTY/UNIT		REMARKS 備考
							LXE10E-		
							A24R	A9R	
M0			Power changeover box ass'y	電源切替ボックス組立品	2P143049-1		1	1	
M1			Cam switch	カムスイッチ	2P142924-1		1	1	
M2			Power changeover box welding ass'y	電源切替ボックス溶接組立品	2P142883-1		1	1	
M3			Power changeover box cover ass'y	電源切替ボックス蓋溶接組立品	3P142911-1		1	1	
M4		0758640	Cable conector	ケーブルコネクタ	3PA37599-5		1	1	
M5		0758626	Cable conector	ケーブルコネクタ	3PA37599-6		3	3	
M6		0758657	Cable conector	ケーブルコネクタ	3PA37599-7		1	1	
M7		0037646	Snap switch	スナップスイッチ	3PA19977-1		1	1	
M8			Fixing plate, lamp	ランプ固定具	4P143026-1		1	1	
M9		1455797	Ararm lamp	警報ランプ	ACS02G004-1		1	1	
M10		0907062	Seal washer	シール座金	4PA21941-5		2	2	
M11		833012	Patch plate unit	当板ナット	R4718017-1		1	1	
M12			Packing, lamp	パッキン (ランプ)	4P012239-1		1	1	
M13		0029373	Rubber washer	ボルト脱落防止ゴム	R4717334-1		4	4	
M14			Hexiagon bolt	コイル溝付六角ボルト	R4716504-8		4	4	
M15			Gasket power changeover box cover	電源切替ボックス蓋パッキン	4P142939-1		1	1	
M16		990053	Band hose	ホース用バンド	R4716528-3		1	1	
M17		0907156	Name plate, grounding	アース銘板	YA41022-3		1	1	
M18			Alarm lamp, switch cable	アラームランプスイッチケーブル	3P143104-1		1	1	
M19			Earth wire, power changeover box	電源切替BOX内アース線	4P145520-1		1	1	
N1			Alarm buzzer	警報ブザー	ACS040084		1	1	
N2			Hexiagon bolt	六角ボルト	4P048685-20		3	3	
N3		841011S	Spring washer	バネ座金	4SK07110-5		3	3	
N4		844014S	Plane washer	平ワッシャー	4SK07005-5		1	1	
N5			Alarm buzzer cable	アラームブザーケーブル	3P144485-1		1	1	

● When ordering the parts whose No. are not shown in the PARTS NO. column, be sure to describe DWG. NO..

● 部品番号欄が空白になっている部品は、図面番号で、指示願います。

1. Resin clamp

1. 樹脂バンド

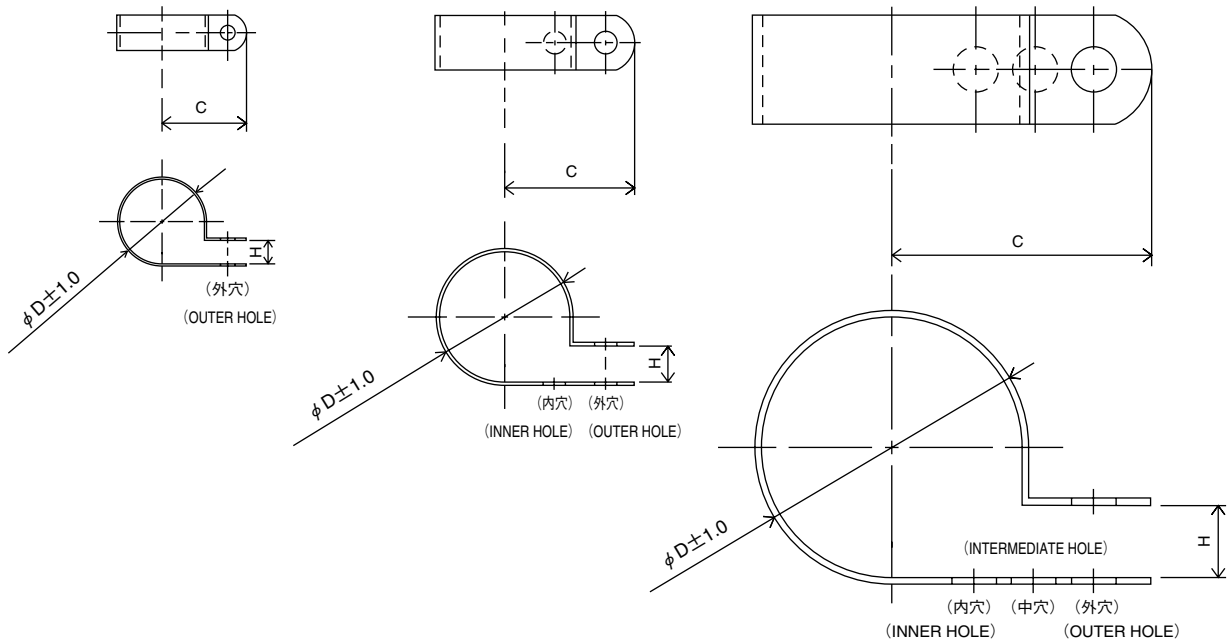

NO. 符号	PARTS NO. 部品番号	PARTS NAME	部品名称	DWG NO. 図面番号	SIZE サイズ			QTY 使用個数
					D	C	H	
E9	0118273	Resin clamp	樹脂バンド	NE41015-2	6.8	15.8	4.8	4
E10	1222764	Resin clamp	樹脂バンド	NE41015-9	26.9	27.8	7.9	1
E11	0944528	Resin clamp	樹脂バンド	NE41015-7	19.8	24.6	7.9	2
E12	0142492	Resin clamp	樹脂バンド	NE41015-10	29.2	29.4	7.9	2
E13	1266788	Resin clamp	樹脂バンド	NE41015-12	39.4	34.2	9.5	4

## 2. Tube clamp

### 2. 管止金

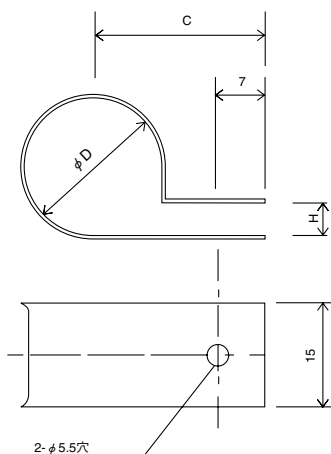

NO. 符号	PARTS NO. 部品番号	PARTS NAME	部品名称	DWG NO. 図面番号	SIZE サイズ			QTY 使用個数
					D	C	H	
E6	1270439	Tube clamp	管止め金	NE31016-61	30	30	5	2
E15	0782775	Tube clamp	管止め金	NE31016-51	10	20	3	5
E16	1584215	Nylon coating tube clamp	ナイロンコーティング管止め金	4P143802-51	10	20	3	4
E17	1584208	Nylon coating tube clamp	ナイロンコーティング管止め金	4P143802-52	12	21	3	2
E19	1584222	Nylon coating tube clamp	ナイロンコーティング管止め金	4P143802-54	16	23	4	1
E21	0016290	Tube clamp	管止め金	NE31016-56	20	25	5	1
E22	1584239	Nylon coating tube holder	ナイロンコーティング管止め金	4P143802-71	6.4	20	1	6
E27	1266858	Tube clamp	管止め金	NE31016-59	26	28	5	1
E29	1584246	Nylon coating tube clamp	ナイロンコーティング管止め金	4P143802-59	26	28	5	1

## 3. Cushion rubber for pipe clamp

### 3. 管止金用緩衝ゴム

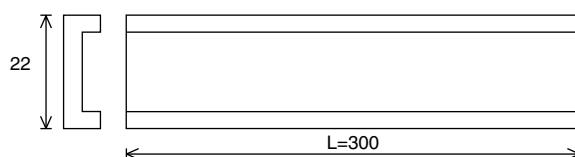

NO. 符号	PARTS NO. 部品番号	PARTS NAME	部品名称	DWG NO. 図面番号	REMARKS
					備考
E35	1584253	Cushion rubber	管止金用緩衝ゴム	NE41013-3-300	Cut to suit pipe size. 配管サイズに合わせて切って使用のこと

1. Parts recommended to be ordered together with packing, gasket, sealing material and name plate
1. 発注の際にパッキングやシール材、銘板等の同時発注を推奨する部品

For ordering following spare parts, we recommend that you order the following packing, gasket, sealing material and name plate together at the same time.

上記のサービス扉やボックスカバーを発注の際には、下記のパッキングを同時に発注することをおすすめします。

(1) Service door

(1) サービス扉

NO. 符号	PARTS NO. 部品番号	PARTS NAME	部品名称	DWG NO. 図面番号	REMARKS 備考
A4	1612576	Accesses panel ass'y	サービス扉組立品	1P006678-5	(Without cushion and sealing material) (クッション材、シール材なし)
A5	1266207	Cushion material (access panel)	クッション材 (サービス扉)	3P033608-1	
A6	1196113	Sealing material (access panel)	シール材 (サービス扉)	3P001640-2	

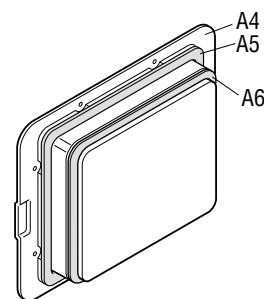

(2) Control box cover

(2) コントロールボックスカバー

NO. 符号	PARTS NO. 部品番号	PARTS NAME	部品名称	DWG NO. 図面番号
F7-4		Control box cover welding ass'y	コントロールボックス蓋溶接組立品	3P143217-1
F7-7	1381081	Rubber gasket	ゴムガスケット (C. BOX蓋用パッキン)	4P085198-1
G3	1564879	LABEL	操作銘板 (C&MODE, 和・英)	1P142887-1
G27		Name plate, unit switch	ユニットスイッチ銘板	3P145645-1

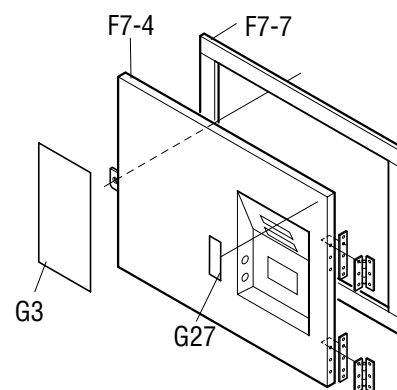

※Wiring diagram name plate is different by model.

※電気配線図銘板は機種により異なります。

( 3 ) Recorder box cover (Option)

( 3 ) レコーダボックスカバー (オプション)

NO. 符号	PARTS NO. 部品番号	PARTS NAME	部品名称	DWG NO. 図面番号
H8	1587656	Cover (recorder)	蓋 (レコーダ)	1P054302-4
H9	1267868	Packing (recorder cover)	パッキン (蓋)	4P063866-1
G11		Recorder box Name plate	レコーダボックス 銘板 (英・和)	3P116519-1

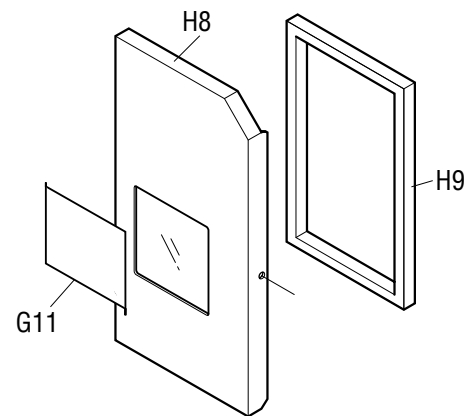

( 4 ) Ventilation cover

( 4 ) 換気口蓋

NO. 符号	PARTS NO. 部品番号	PARTS NAME	部品名称	DWG NO. 図面番号
A19	1266120	Ventilation cover	換気口蓋	3P067053-1
A20	1266221	Sealing material (access panel)	シール材 (換気口)	4P016185-1

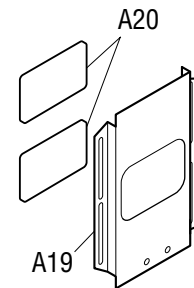

( 5 ) Front plate (CA)

( 5 ) 前板 (CA)

NO. 符号	PARTS NO. 部品番号	PARTS NAME	部品名称	DWG NO. 図面番号
A15		Front plate(CA)	前板 (C A)	2P143084-1
G4	1306530	Brand name label	意匠銘板	4P085985-1
G10	1178843	Name plate, refrigerant	冷媒銘板	3P009750-1

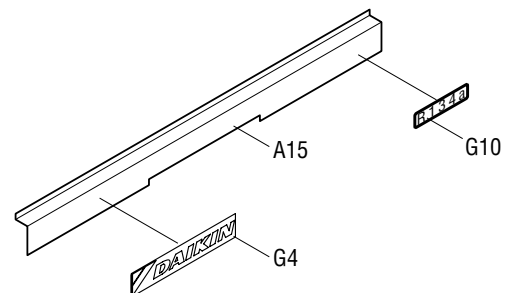

## 2. Order for motorized valve, solenoid valve and pressure regulating valve

### 2. 電動弁・電磁弁・圧力調整弁の発注

Refer to the following table for the name, main body, solenoid coil and ass'y of solenoid valves etc. applied to this model.

この機種に使用されている電磁弁等の名称と本体・コイル・組立品は下記のとおりです。

	Body/Coil 本体/コイル	NO. 符号	PARTS NO. 部品番号	PARTS NAME	部品名称	DWG NO. 図面番号	Common Parts 共通部品		
							NEV-803DXF	NEV-202DXF	NEV-MOAB507C
1.EV	本体 Body	B7-3	1256495	Electronic expansion valve body	電子膨張弁本体	2SA50010-2-KU			
	コイル Coil	B20	1381430	Electronic expansion valve coil	電子膨張弁コイル	2P010454-2			
2.HSV	本体 Body	B7-4	0944566	Hot gas solenoid valve body	ホットガス電磁弁本体	R3305118-1	○		
	コイル Coil	B7-5	1266290	Hot gas solenoid valve coil	ホットガス電磁弁コイル	3P010453-2			○
3.DSV	本体 Body	B7-4	0944566	Defrost bypass solenoid valve body	デフロストバイパス電磁弁本体	R3305118-1	○		
	コイル Coil	B7-5	1266290	Defrost bypass solenoid valve coil	デフロストバイパス電磁弁コイル	3P010453-2			○
4.BSV	本体 Body	B7-4	0944566	Gas bypass solenoid valve body	ガスバイパス電磁弁本体	R3305118-1	○		
	コイル Coil	B7-5	1266290	Gas bypass solenoid valve coil	ガスバイパス電磁弁コイル	3P010453-2			○
5.ESV	本体 Body	B7-6	0088738	Economizer solenoid valve body	エコノマイザー電磁弁本体	R3305099-1-KI		○	
	コイル Coil	B7-5	1266290	Economizer solenoid valve coil	エコノマイザー電磁弁コイル	3P010453-2			○
6.ISV	本体 Body	B7-6	0088738	Injection solenoid valve body	インジェクション電磁弁本体	R3305099-1-KI		○	
	コイル Coil	B7-5	1266290	Injection solenoid valve coil	インジェクション電磁弁コイル	3P010453-2			○
7.LSV	本体 Body	B4-5	0944566	Liquid solenoid valve body	液電磁弁本体	R3305118-1	○		
	コイル Coil	B4-6	0955287	Liquid solenoid valve coil	液電磁弁コイル	3P010453-1			○
8.SMV	組立品 Ass'y	B8-1	1254538	Suction modulating Valve	吸入比例弁組立品	2P078385-1			Note 1 注 1
9.DPR	組立品 Ass'y	B3-4	1241361	Discharge pressure regulating valve	吐出圧力調整弁	3P074558-1			

Note 1 : Refer Page 32、33 and 34 for detail parts of suction modulating valve.

注 1 : SMV（吸入比例弁）の詳細部品はP.32、33、34を参照ください。

Note 2 : Difference of solenoid valve No.1266290 and 0955287.

No.1266290 (3P010453-2) : Lead wire length 1550mm

No.0955287 (3P010453-1) : Lead wire length 2000mm

注 2 : 電磁弁No.1266290とNo.0955287の違い。

No.1266290 (3P010453-2) : リード線長さ1550mm

No.0955287 (3P010453-1) : リード線長さ2000mm

### 3. Order for pressure trasducer

### 3. 圧力センサーの発注

Refer to the following table for the pressure transducer applied to this model.

For ordering pressure transducer, we recommend that you order the following best shrinkable tube together at the same time.

この機種に使用している圧力センサーは下記の通りです。

圧力センサー発注の際は、下記の熱収縮チューブを同時に発注することをおすすめします。

呼称名	NO. 符号	PARTS NO. 部品番号	PARTS NAME	部品名称	DWG NO. 図面番号	TYPE 形式	REMARKS 備考
HPT	B16	1587959	High pressure transducer	高圧圧力センサー	3P141602-1	SPCH01	
LPT	B15	1587942	Low pressure transducer	低圧圧力センサー	3P141601-1	SPCL02	
	E84	1605509	Heat shrinkable tube	熱収縮チューブ	4P151322-1		Must be applied when replacing above sensors. 上記圧力センサー交換時使用の事。



## 4. Order for temperature sensor

### 4. 温度センサーの発注

Refer to the following table for temperature sensors applied to this model.

この機種に使用されている温度センサーは下記の通りです。

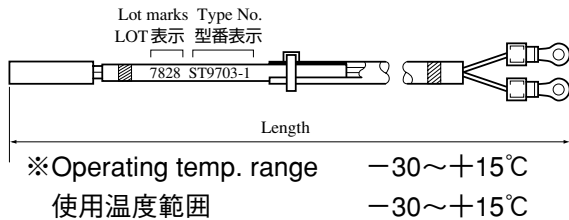
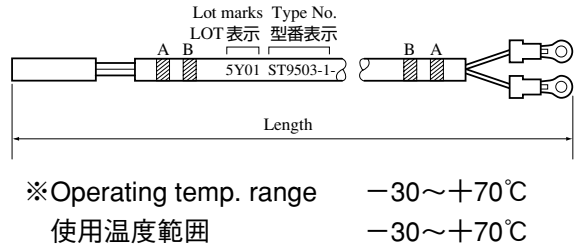
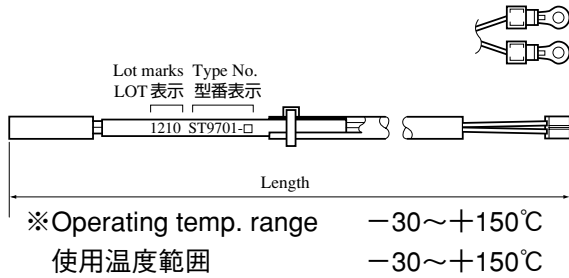

※1 Location 取付場所

Indoor A : Indoor supply air side

Indoor B : Indoor return air side

庫内A : 庫内吹出空気側

庫内B : 庫内吸込空気側

呼称	NO. 符号	PARTS NO. 部品番号	PARTS NAME 部品名称	DWG. NO. 図番	TYPE 形式	WIRE COLOR 配線色		LENGTH 全長mm	※1 LOCATION 取付場所	TEMPORALY EXCHANGABILITY 緊急時互換性
						A	B			
1. SS	C24	0798299	Supply air temp. sensor	3PA61769-3	ST9503-3	green 緑	- -	3200	Indoor A 庫内A	○
2. DSS	C25	0798770	Data recorder supply air temp. sensor	3PA61769-8	ST9503-8	green 緑	Red 赤	3200	Indoor A 庫内A	○
3. RS	C26	0798275	Return air temp. sensor	3PA61769-1	ST9503-1	Blue 青	- -	3200	Indoor B 庫内B	○
4. DRS	C27	0798732	Data recorder return air temp. sensor	3PA61769-7	ST9503-7	Blue 青	Red 赤	3200	Indoor B 庫内B	○
5. EIS	D4	1562828	Evaporator inlet temp. sensor	3P012118-2	ST9703-1	Brown 茶	- -	3200	Indoor EVP. 庫内蒸発器	
6. EOS	D5	1562835	Evaporator outlet temp. sensor	3PA61769-15	ST9503-5	Yellow 黄	- -	3200	Indoor EVP. 庫内蒸発器	○
7. DCHS	B11	0983321	Discharge pipe temp. sensor	3SA48009-10	ST9701-10	-	-	2800	Outdoor 庫外	
8. AMBS	B12	0798321	Ambient air temp. sensor	3PA61769-6	ST9503-6	- -	- -	3200	Outdoor 庫外	○
9. SGS	B13	0983338	Compressor suction gas temp. sensor	3PA61769-9	ST9503-9	White 白	- -	3200	Outdoor 庫外	○
10. RSS	H23	0798307	Recorder supply air sensor	3PA61769-4	ST9503-4	green 緑	green 緑	3200	Indoor A 庫内A	○
11. RRS	H24	0798282	Recorder return air sensor	3PA61769-2	ST9503-2	Blue 青	Blue 青	3200	Indoor B 庫内B	○

## 1. Tools for emergency operation

### 1. 緊急運転用工具

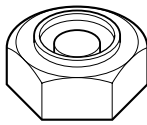
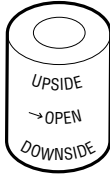
NO. 符号	PARTS NO. 部品番号	PARTS NAME 部品名称	DWG NO. 図面番号	USE 用途	ILLUSTRATION 姿図
-	1080263	Emergency coil cap エマージェンシー コイルキャップ	3P017370-1	For electronic expansion valve 電子膨張弁用	
-	1270530	Emergency magnet エマージェンシー マグネット	2P078385-2	Suction modulating valve 吸入比例弁用	

(See Service Manual for application.)

(使用方法はサービスマニュアルを参照ください。)

## 2. Personal computer cable (for DCCS)

### 2. パソコンケーブル (DCCS用)

The following parts are connector cables required to exchange information between the refrigeration unit and personal computer. The table below describes parts required to apply to Model LXE-C, -D, and -E new model.

下記の部品は冷凍ユニットとパソコンの情報交換に必要なコネクタ、ケーブル類です。LXE-C型、D型、及び新機種E型対応に必要な部品を掲載しています。

#### [TYPE A]タイプA

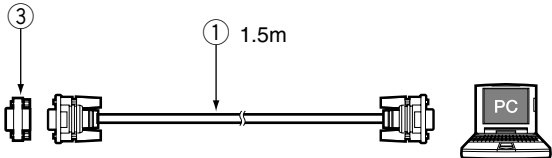
LXE10C LXE10CA LXE10D for MOL	LXE10C LXE10CA MOL用LXE10D	
(Receptacle) RS232C (Female) on the controller	(レセプタクル) RS232C (メス) コントローラー側	

#### [TYPE B]タイプB

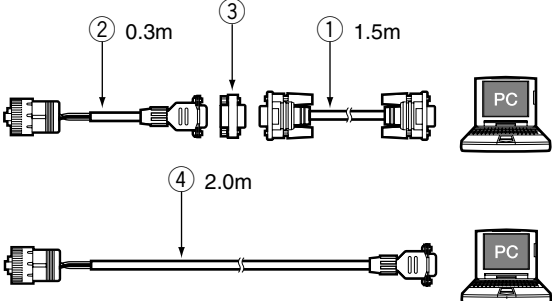
LXE10D LXE10E	LXE10D LXE10E	
(Receptacle) Water proof type on the unit	(レセプタクル) コンテナ冷凍機 ユニットの防水型	

(1) Parts No.

(1) 部品番号

NO. 符号	PARTS NO. 部品番号	PARTS NAME	部品名称	REMARKS 備考
①	Local supply 市販品	Connection cable (reverse)	接続ケーブル (リバース)	RS232C reverse (cross) type RS232Cリバース (クロス) 型
②	9993324	Connection cable	接続ケーブル	
③	Local supply 市販品	Adapter (gender changer)	アダプター (ジェンダーチェンジャー)	D-sub 9P, Male-Male Dサブ9ピン、オス-オス
④	1087149	Connection cable	接続ケーブル	

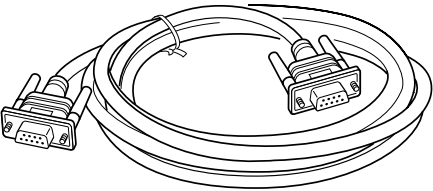
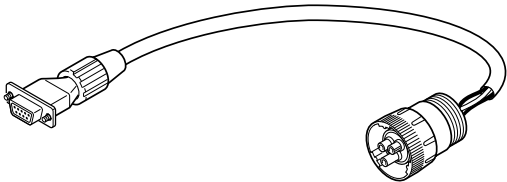
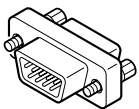
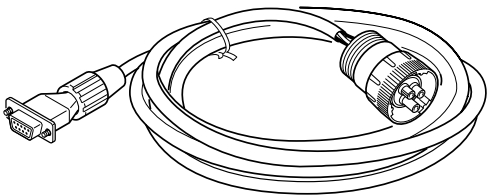
NO. 符号	Illustration 姿図	Internal Wiring 内部配線																																																									
①		<p>RS232C Female メス</p> <table border="1"> <tr><td>1</td><td></td><td>1</td></tr> <tr><td>2</td><td></td><td>2</td></tr> <tr><td>3</td><td></td><td>3</td></tr> <tr><td>4</td><td></td><td>4</td></tr> <tr><td>5</td><td></td><td>5</td></tr> <tr><td>6</td><td></td><td>6</td></tr> <tr><td>7</td><td></td><td>7</td></tr> <tr><td>8</td><td></td><td>8</td></tr> <tr><td>Frame</td><td></td><td>フレーム</td></tr> </table> <p>RS232C Female メス</p> <table border="1"> <tr><td>1</td><td></td><td>1</td></tr> <tr><td>2</td><td></td><td>2</td></tr> <tr><td>3</td><td></td><td>3</td></tr> <tr><td>4</td><td></td><td>4</td></tr> <tr><td>5</td><td></td><td>5</td></tr> <tr><td>6</td><td></td><td>6</td></tr> <tr><td>7</td><td></td><td>7</td></tr> <tr><td>8</td><td></td><td>8</td></tr> <tr><td>Frame</td><td></td><td>フレーム</td></tr> </table>	1		1	2		2	3		3	4		4	5		5	6		6	7		7	8		8	Frame		フレーム	1		1	2		2	3		3	4		4	5		5	6		6	7		7	8		8	Frame		フレーム			
1		1																																																									
2		2																																																									
3		3																																																									
4		4																																																									
5		5																																																									
6		6																																																									
7		7																																																									
8		8																																																									
Frame		フレーム																																																									
1		1																																																									
2		2																																																									
3		3																																																									
4		4																																																									
5		5																																																									
6		6																																																									
7		7																																																									
8		8																																																									
Frame		フレーム																																																									
②		<p>Daikin made ダイキン製</p> <table border="1"> <tr><td>A</td><td>Red</td><td>1</td></tr> <tr><td>B</td><td>White</td><td>2</td></tr> <tr><td>C</td><td>Black</td><td>3</td></tr> <tr><td></td><td></td><td>4</td></tr> <tr><td></td><td></td><td>5</td></tr> <tr><td></td><td></td><td>6</td></tr> <tr><td></td><td></td><td>7</td></tr> <tr><td></td><td></td><td>8</td></tr> <tr><td></td><td></td><td>9</td></tr> </table> <p>RS232C Female メス</p> <table border="1"> <tr><td>1</td><td></td><td>1</td></tr> <tr><td>2</td><td></td><td>2</td></tr> <tr><td>3</td><td></td><td>3</td></tr> <tr><td>4</td><td></td><td>4</td></tr> <tr><td>5</td><td></td><td>5</td></tr> <tr><td>6</td><td></td><td>6</td></tr> <tr><td>7</td><td></td><td>7</td></tr> <tr><td>8</td><td></td><td>8</td></tr> <tr><td>9</td><td></td><td>9</td></tr> </table>	A	Red	1	B	White	2	C	Black	3			4			5			6			7			8			9	1		1	2		2	3		3	4		4	5		5	6		6	7		7	8		8	9		9			
A	Red	1																																																									
B	White	2																																																									
C	Black	3																																																									
		4																																																									
		5																																																									
		6																																																									
		7																																																									
		8																																																									
		9																																																									
1		1																																																									
2		2																																																									
3		3																																																									
4		4																																																									
5		5																																																									
6		6																																																									
7		7																																																									
8		8																																																									
9		9																																																									
③																																																											
④		<p>Daikin made ダイキン製</p> <table border="1"> <tr><td>A</td><td>Red 赤</td><td>1</td></tr> <tr><td>B</td><td>White 白</td><td>2</td></tr> <tr><td>C</td><td>Black 黒</td><td>3</td></tr> <tr><td></td><td></td><td>4</td></tr> <tr><td></td><td></td><td>5</td></tr> <tr><td></td><td></td><td>6</td></tr> <tr><td></td><td></td><td>7</td></tr> <tr><td></td><td></td><td>8</td></tr> <tr><td></td><td></td><td>Frame</td></tr> <tr><td></td><td></td><td>フレーム</td></tr> </table> <p>RS232C Female メス</p> <table border="1"> <tr><td>1</td><td></td><td>1</td></tr> <tr><td>2</td><td></td><td>2</td></tr> <tr><td>3</td><td></td><td>3</td></tr> <tr><td>4</td><td></td><td>4</td></tr> <tr><td>5</td><td></td><td>5</td></tr> <tr><td>6</td><td></td><td>6</td></tr> <tr><td>7</td><td></td><td>7</td></tr> <tr><td>8</td><td></td><td>8</td></tr> <tr><td>Frame</td><td></td><td>フレーム</td></tr> </table>	A	Red 赤	1	B	White 白	2	C	Black 黒	3			4			5			6			7			8			Frame			フレーム	1		1	2		2	3		3	4		4	5		5	6		6	7		7	8		8	Frame		フレーム
A	Red 赤	1																																																									
B	White 白	2																																																									
C	Black 黒	3																																																									
		4																																																									
		5																																																									
		6																																																									
		7																																																									
		8																																																									
		Frame																																																									
		フレーム																																																									
1		1																																																									
2		2																																																									
3		3																																																									
4		4																																																									
5		5																																																									
6		6																																																									
7		7																																																									
8		8																																																									
Frame		フレーム																																																									

<https://daikin-p.ru>

# MEMO

<https://daikin-p.ru>

# MEMO

<https://daikin-p.ru>

**ダイキン工業株式会社**  
**DAIKIN INDUSTRIES, LTD.**

本 社 大阪市北区中崎西2丁目4番12号 梅田センタービル  
郵便番号 530-8323 電話 大阪 (06) 6373-1201 (大 代 表)  
東京支社 東京都港区港南2-18-1 JR品川イーストビル10階  
郵便番号 108-0075 電話 東 京 (03) 6716-0420

Head Office. Umeda Center Bldg., 4-12, Nakazaki-Nishi 2-chome, Kita-ku, Osaka, 530-8323 Japan.

Tel: 06-6373-4338

Fax: 03-6373-7297

Tokyo Office. JR Shinagawa East Bldg., 10F 18-1, Konan 2-chome, Minato-ku Tokyo, 108-0075 Japan.

Tel: 03-6716-0420

Fax: 03-6716-0230