

<https://daikin-p.ru>

DAIKIN

Marine type

Container Refrigeration Unit

Service manual

Model

LKN5AD7

DANGER

Do not disconnect plug until power supply is shut off.

CAUTION

Do not start the unit until plugs are connected and generator plant is operated.

NOTE

- 1 . Confirm the function of the watch of the electronic temperature controlling recorder and the life of battery when a chart paper is replaced.
- 2 . Tighten control box cover securely.

Index

	Page
1. General specifications	1
1.1 Specifications	1
1.2 Electrical characteristics	1
1.3 Set values of functional parts	2
2. Construction	3
2.1 External appearance of unit	3
2.2 Control box	4
3. Piping diagram	5
4. Wiring diagram	6
4.1 Sequence wiring	6
4.2 Actual wiring	7
5. Operating instructions	9
5.1 Operating instructions	9
5.2 Cooling and heating operation	10
5.3 Air cooled and water cooled operation	11
5.4 Defrosting operation	12
5.5 Pilot lamps and remote monitoring lamps	13
6. Periodical inspection	14
7. Inspection and adjusting methods	15
7.1 Electronic temperature controller	15
7.2 Air pressure switch for defrost initiation	29
7.3 Dual pressure switch	31
8. Trouble and countermeasures	32
9. Maintenance	34
9.1 Replacement of fusible plug	35
9.2 Replacement of dryer	36
9.3 Purging of non-condensable gas	36
9.4 Additional charge of refrigerant	37
9.5 Vacuum drying and charging refrigerant and lubricant	37
9.6 Gas leakage test	38
9.7 Caution for replacement of flexible tube	39
9.8 Caution for replacement of compressor	40

1. General specifications

1.1 Specifications

Model	LKN5AD7		
Power supply	AC 200V	3 Phase	50/60Hz
	AC 220V	3 Phase	60Hz
	AC 380 ~ 415V	3 Phase	50Hz
	AC 440V	3 Phase	60Hz
Compressor	Semi hermetic type (3.75 kW)		
Air cooled condenser	Cross finned coil type		
Water cooled condenser	Shell and finned tube type		
Evaporator	Cross finned coil type		
Fan	Motor direct driven propeller type		
Defrost			
Heat source	Electric heater		
Initiation	Air pressure switch (detecting evaporator pressure difference), timer or manual switch.		
Termination	Thermostat mounted on evaporator		
Refrigerant control	Thermostatic expansion valve		
Protection devices	Circuit breaker, Over current relay, Fuse, Dual pressure switch, Oil pressure protection switch, Fusible plug, Firestat, Compressor motor protection thermostat, Fan motor protection thermostat.		
Refrigerant	R-12 (5.5 kg)		
Lubricant	SUNISO 3GS-D1 (2.3 ℓ)		
Weight	Approx. 520 kg		

1.2 Electric characteristics

Power supply		AC200V 50Hz	AC220V 60Hz	AC415V 50Hz	AC440V 60Hz
Power consumption	Refrigeration operation	kW 5.8	5.8	5.8	5.8
	Heating operation	kW 4.7	4.7	4.7	4.7
Starting current	A	121	121	60	60
Total running current	A	19 (MAX)	19 (MAX)	10 (MAX)	10 (MAX)
Running current	Cooling operation	A 12.9	13.0	6.1	6.7
	Defrosting	A 9.3	10.2	4.8	5.1
	Heating operation	A 11.6	13.3	6.0	6.8

Note; Running current for refrigeration operation is based on ambient temp. 38°C, storage temp. –18°C.

1.3 Set values of functional parts

Part name	Function	Set value
Oil pressure control switch ONS-C106Q	Heater circuit OFF ON Timer	1.0 kg/cm ² 0.5 kg/cm ² 110 seconds (ambient temperature 25°C) More than 5 seconds (ambient temperature 70°C)
Dual pressure switch DNS-D306Q	Low pressure OFF ON High pressure OFF ON	40 cmHgV 0.2 kg/cm ² 20 kg/cm ² 16.5 kg/cm ²
High pressure switch SNS-C130Q	OFF ON	7 kg/cm ² 11 kg/cm ²
Water pressure switch SNS-C106WQ	OFF ON	1.0 kg/cm ² 0.4 kg/cm ²
Firestat KLIXON 20420L/L160-4	OFF ON	71°C (160°F) 49°C (120°F)
Defrost termination switch KLIXON 20420L/L45-1	OFF ON	7.2°C (45°F) 1.67°C (35°F)
Air pressure switch for defrost BEC No. 19-R70-B20-A2.5	ON	20mmH ₂ O
Defrost timer STP-73	ON	24h (60 Hz) 28½h (50 Hz)
Overcurrent relay CR-20-NP ₂ S ₄	OFF	5.5A

2. Construction

2.1 External appearance of unit

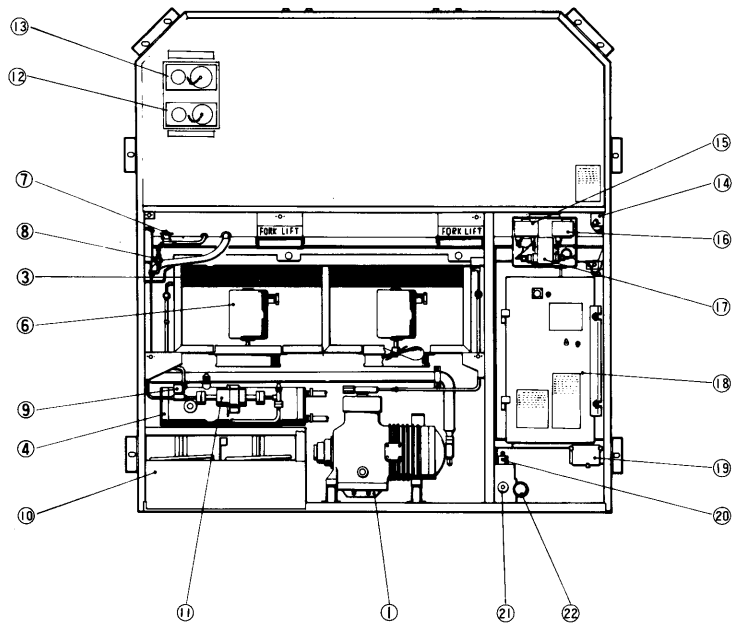
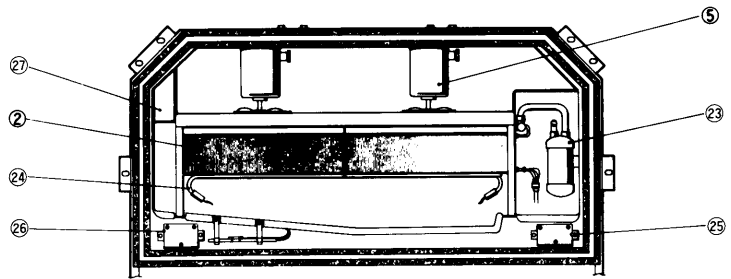
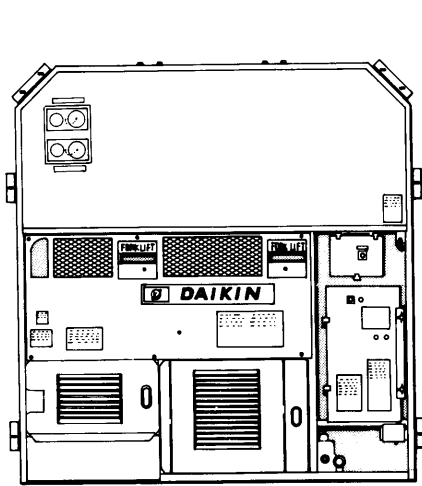

- ① Compressor
- ② Evaporator
- ③ Air cooled condenser
- ④ Water cooled condenser
- ⑤ Evaporator fan motor
- ⑥ Condenser fan motor
- ⑦ Expansion valve
- ⑧ Moisture indicator
- ⑨ Solenoid valve
- ⑩ Cable storage
- ⑪ Dryer
- ⑫ Air intake
- ⑬ Air outlet
- ⑭ Air pressure switch for defrosting

- ⑮ Dual pressure switch
- ⑯ High pressure control switch
- ⑰ Oil pressure control switch
- ⑱ Control box
- ⑲ Water pressure switch
- ⑳ Water regulator
- ㉑ Water inlet coupling
- ㉒ Water outlet coupling
- ㉓ Accumulator
- ㉔ Defrost heater
- ㉕ Junction terminal box, lower (A)
- ㉖ Junction terminal box, lower (B)
- ㉗ Junction terminal box, upper

2.2 Control box

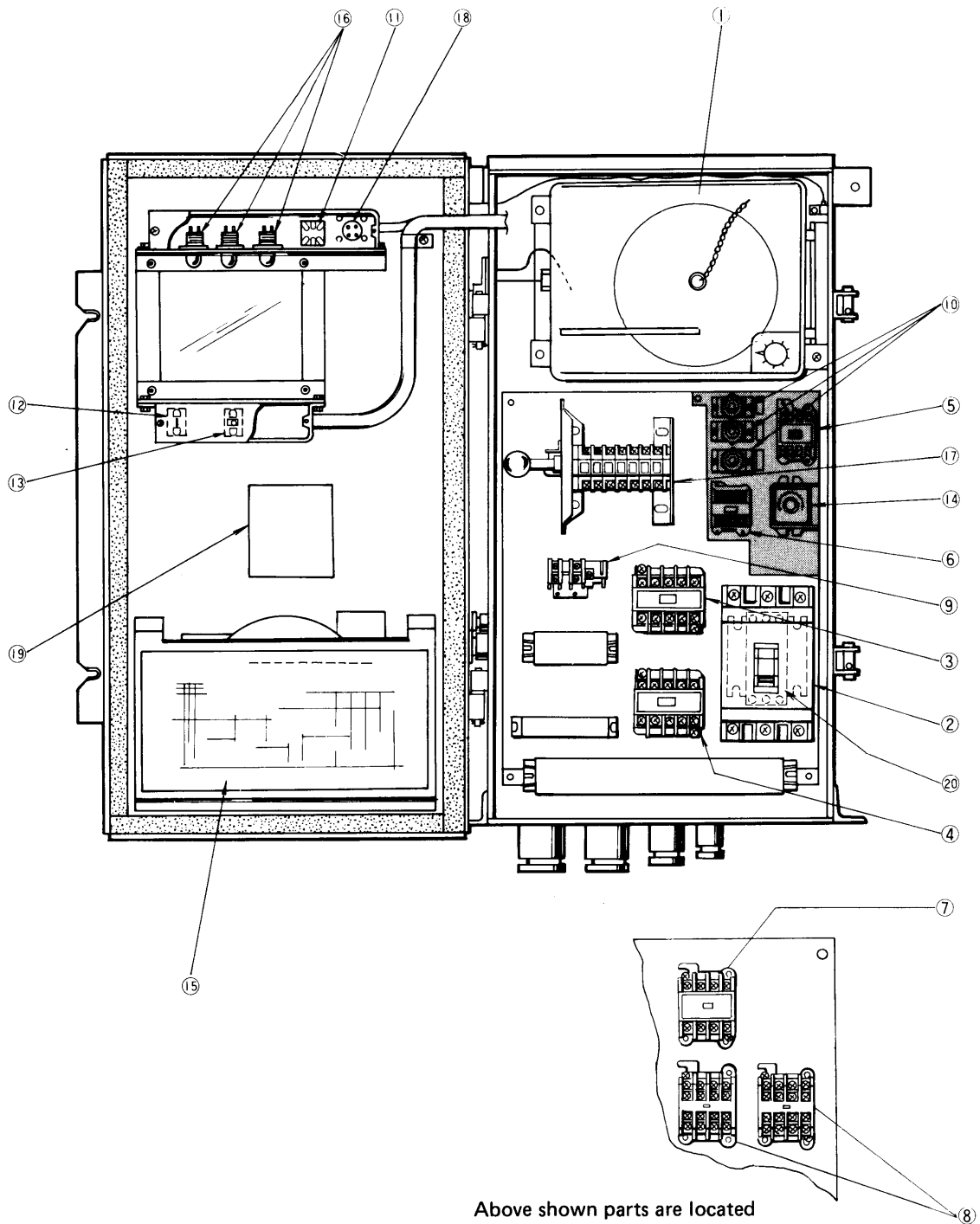

Above shown parts are located under the shaded area.

- | | |
|---|------------------------------------|
| ① Electronic recording temperature controller | ⑪ Snap switch for lamp |
| ② Circuit breaker | ⑫ Snap switch for operating |
| ③ Magnetic switch for compressor | ⑬ Snap switch for defrosting |
| ④ Magnetic switch for heater | ⑭ Timer |
| ⑤ Magnetic switch for fan motor | ⑮ Wiring diagram |
| ⑥ Magnetic relay for defrosting | ⑯ Pilot lamp |
| ⑦ Magnetic switch for crankcase heater | ⑰ Cam switch |
| ⑧ Magnetic relay for power supply exchange | ⑱ Cannon receptacle for pilot lamp |
| ⑨ Over current relay | ⑳ Transformer |
| ⑩ Fuse | |

3. Piping diagram

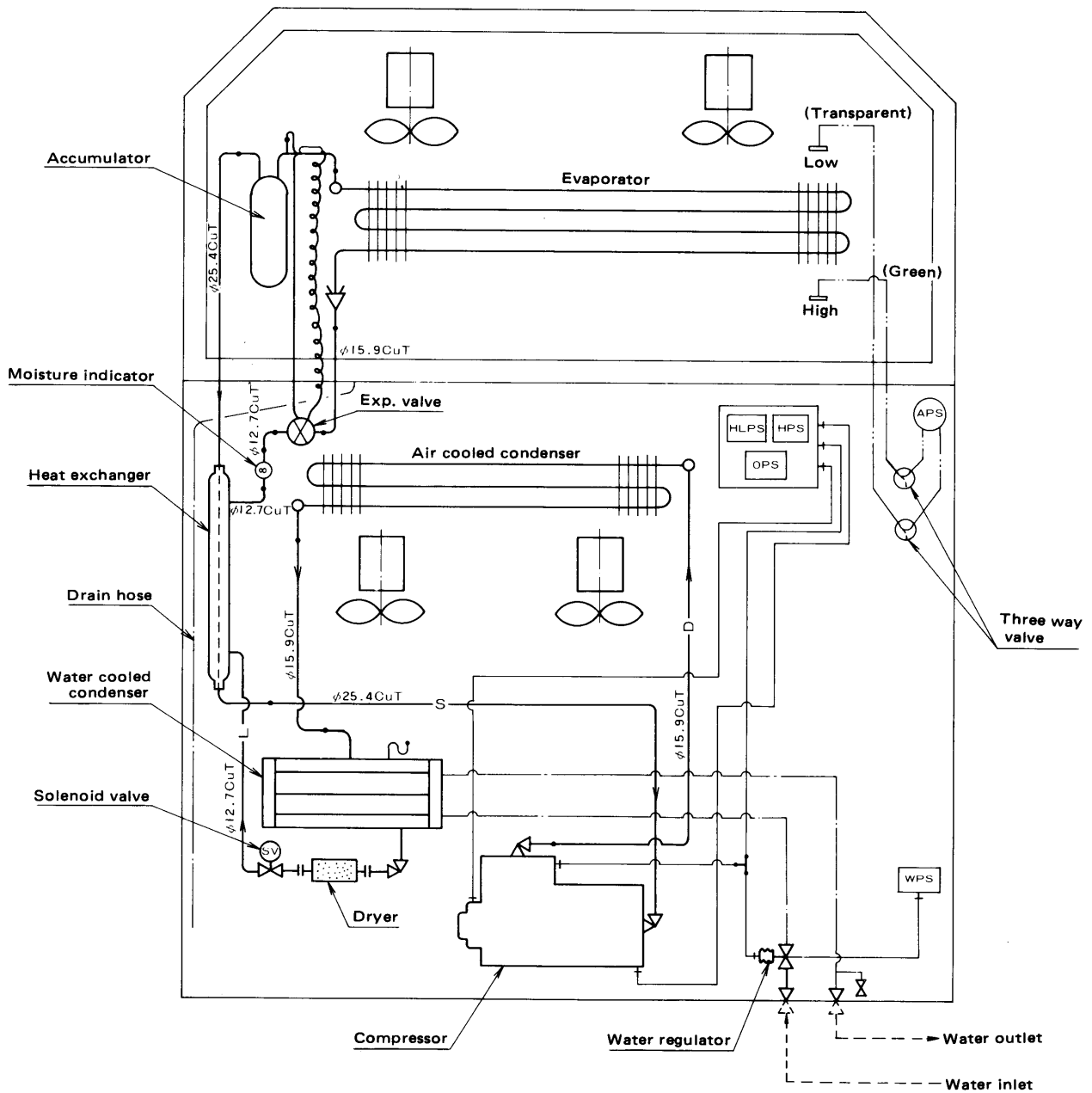

- | | | |
|---------|----------------|------------------------------------|
| — L — | Liquid pipe | HLPS: Dual press. switch |
| — S — | Suction pipe | OPS : Oil press. protection switch |
| — D — | Discharge pipe | HPS : High press. control switch |
| —●— | Brazing | APS : Air press. switch |
| —+— | Flare conn. | WPS : Water press. switch |
| —H— | Flange conn. | |
| — — — | Water pipe | |
| — · · · | Air pipe | |

4. Wiring diagram

4.1 Sequence wiring

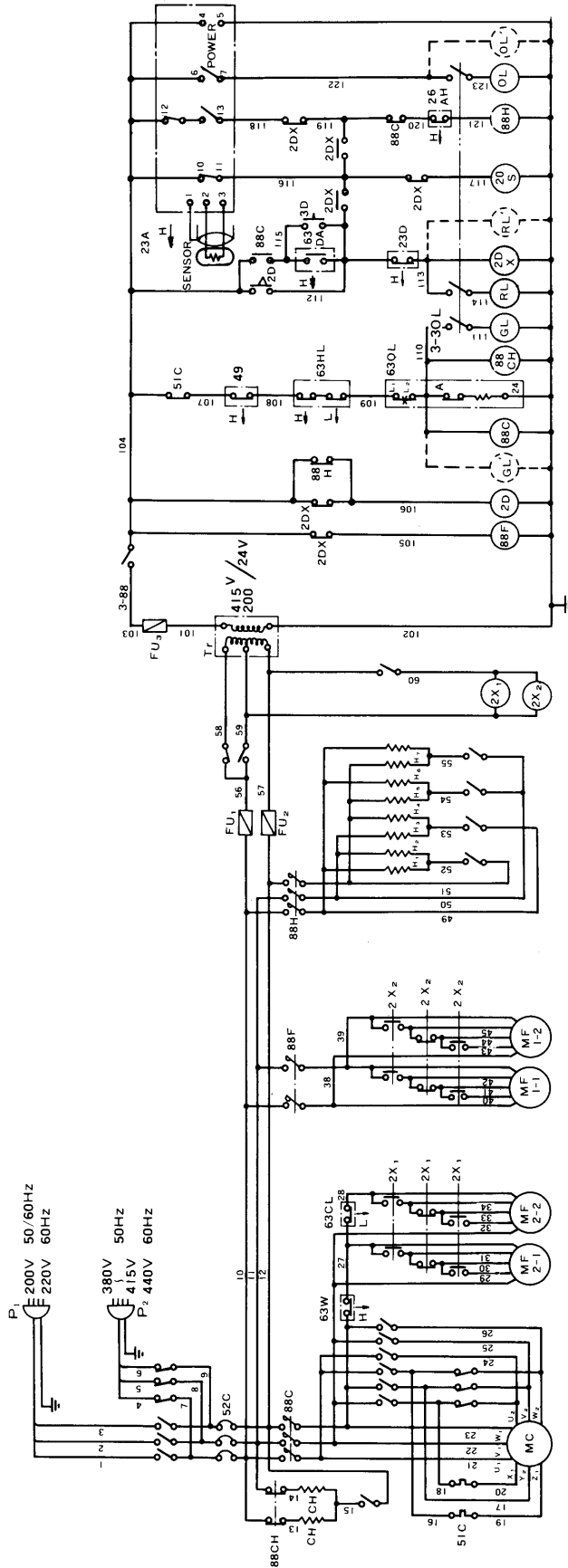

NOTES

1. Monitoring plug connected as follows.

- A : Earth
- B : Operation (GL)
- C : Defrost (RL)
- D : In range temp. (OL)

2. Broken line shows external wiring.

3. Positions of contactors.
(Except 3-88, 3-30L)

Symbol	Voltage	Contactors
	380 ~ 440	ON
	200 ~ 220	ON

Mark	Name	Mark	Name	Mark	Name
P.1, 2	Power plug	MF1	Evaporator fan motor	63HL	Dual pressure switch
52C	Circuit breaker	MF2	Condenser fan motor	63QL	Oil pressure control switch
88C	Magnetic switch for compressor	H1 ~ H6	Evaporator coil heater	3-30L	Lamp switch
88F	Magnetic switch for fan motor	H7	Drain heater	63DA	Defrost initiation switch
88H	Magnetic switch for heater	CH	Crankcase heater	3D	Manual defrost switch
2X1,2	Magnetic switch	88CH	Magnetic switch for crankcase heater	23D	Defrost termination thermostat
63W	Water pressure switch	3-88	ON-OFF switch	26AH	Firestat
63CL	High pressure control switch	2DX	Magnetic relay	23A	Electronic recording temperature controller
FU1,2,3	Fuse	2D	Defrost timer	GL, RL, OL	Lamp
Tr	Transformer	51C	Over current relay	20S	Solenoid valve
MC	Compressor motor	49	Compressor motor protector		

4.2 Actual wiring

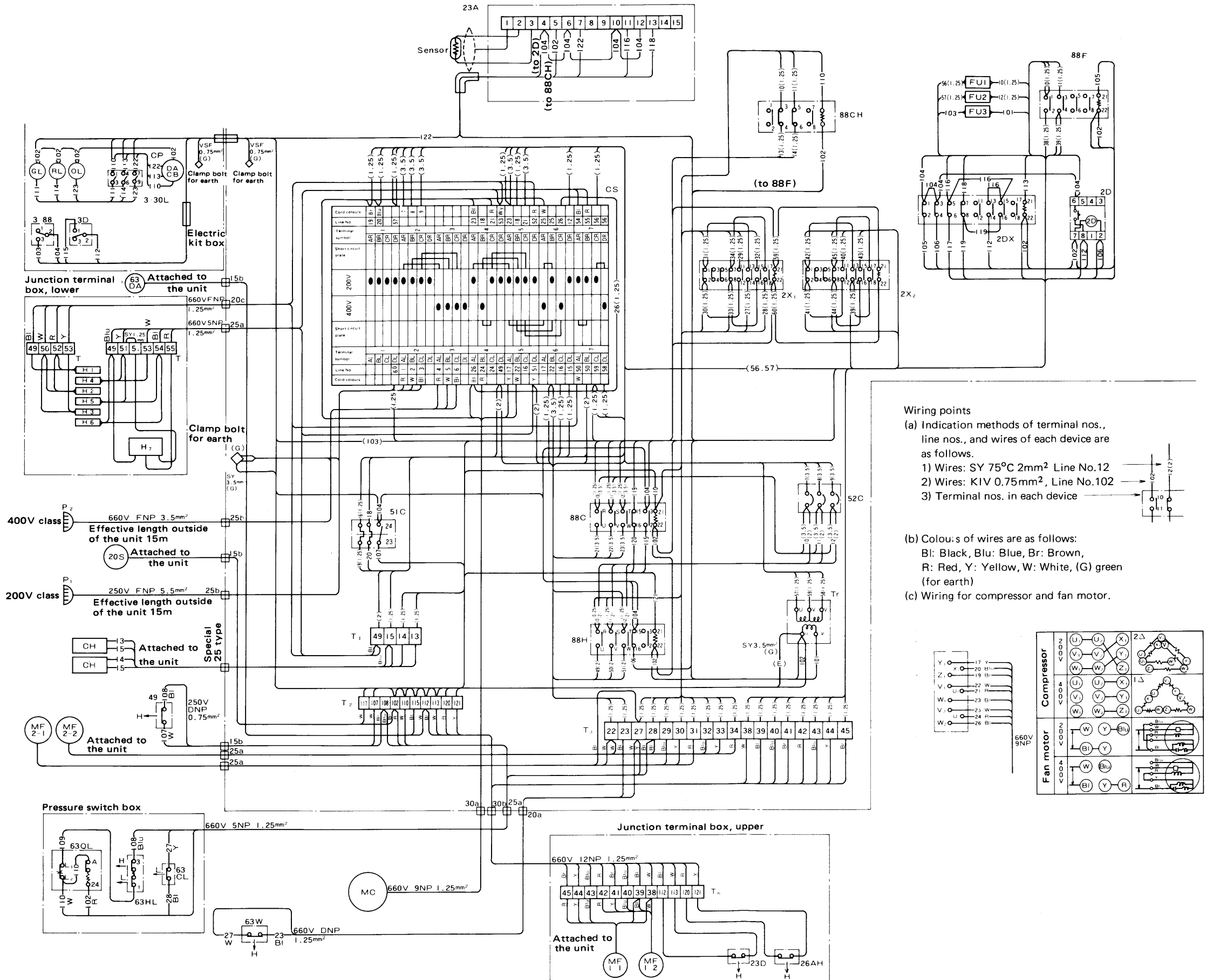

Wiring points

(a) Indication methods of terminal nos., line nos., and wires of each device are as follows.

- 1) Wires: SY 75°C 2mm² Line No.12
- 2) Wires: KIV 0.75mm², Line No.102
- 3) Terminal nos. in each device

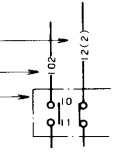

(b) Colours of wires are as follows:

- Bl: Black, Blu: Blue, Br: Brown, R: Red, Y: Yellow, W: White, (G) green (for earth)

(c) Wiring for compressor and fan motor.

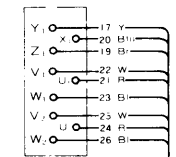

Compressor	Fan motor

5 . Operating instructions

5.1 Operating instructions

Operate the unit according to the following instructions.

(1) Inspection before operation

- (a) Checking of external appearance.
- (b) Fastening of bolts, nuts, magnetic switches, magnetic relays and plugs.
- (c) Checking breakage of wiring in control box and entire system, electrical insulation, clogging of contact points of magnetic switches and magnetic relays.
- (d) Checking oil level of compressor oil level gauge and purity of oil (the oil level should be at the middle of the round window of the gauge)
- (e) Checking the oil pressure control switch for reset.
- (f) Checking drain cock of water cooled condenser for opening during air cooled operation. (to prevent water freezing)
- (g) Checking that refrigerant stop valves on the compressor discharging and suction sides, and outlet side of the water cooled condenser or receiver are opened.
- (h) Checking the refrigerant system for leakage.

(2) Connect the cooling water couplings. (In case of water cooling operation)

(3) Set the lever of the manual change-over switch to power source voltage.

(4) Connect the power plug to the power source.

(5) Confirm the function of the watch of the electronic temperature controlling recorder and the life of battery, replace a recording paper, and do temperature setting.

(6) Operate the generator set, if it is used.

(7) When the ambient temperature is low, turn "ON" the power switch at least one hour before operation for crankcase heater "ON".

(8) Turn "ON" the operation switch on the control box cover.

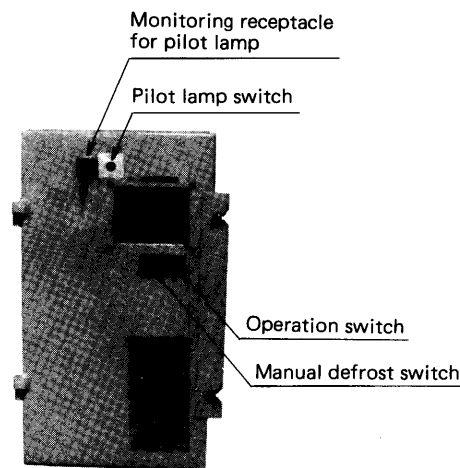

Each switches on the cover of control box

(9) Inspection during operation

- (a) Inspect suction and discharge pressure of the compressor. With regard to attaching gauges, refer to Item 9.
- (b) Check the oil level gauge of the compressor. Oil level during the operation is approx. half the oil level gauge, and oil level during an idle period is a little higher than half.
For a while after start up, the oil level may be invisible, but it will gradually rise. If the oil level is invisible for a long time, it is necessary to discover the cause.
- (c) Confirm lighting and turning off of pilot lamps.
- (d) Be certain of operation of control and protection devices.
- (e) Be certain that there is no unusual noise and vibration.
- (f) Be certain that voltage and current are correct.

(g) Be certain the moisture indication is green. Check if refrigerant flashing is observed.

- Notes:**
1. When outdoor temperature is high during air cooled operation, air bubbles may be contained.
 2. Check colour of the indicator when it is exposed to the liquid refrigerant.
 3. In case the indicator was exposed to the gaseous refrigerant for a long time, put the unit in refrigeration operation for approximately 12 hours (exposed to the liquid refrigerant) and then check colour of the indicator.

(h) Be certain that no oil leakage is found.

(i) Be certain that no liquid back and liquid hammer occur.

Note: Discharge pressure can be kept constantly and not subjected to the ambient temperature during water cooled operation.

5.2 Cooling and heating operation

This unit is capable of both cooling and heating.

The recording temperature controller is capable of switching from the cooling operation to the heating operation and vice versa automatically and maintains storage temperature constant regardless of ambient temperature.

Heating is accomplished by the electric heaters. All the heaters, i.e. heating and defrosting heater installed at the bottom of the evaporator and the heater installed at the drain outlet function.

A manual switch which is turned off when temperature setting is under -6.5°C (20°F) is installed in the heating circuit of the recording temperature controller; i.e. when storage temperature is low, invaded heat becomes large. So there is no need to heat forcedly. If the storage chamber is wrongly heated, stored goods may be damaged. That is the reason why the electric heater does not come into operation when storage temperature is under -6.5°C (20°F).

The compressor and the heater do not come into operation simultaneously. An over-heat protective thermostat is installed on the top of the evaporator to turn off the electric heater in case of abnormal heating.

5.3 Air cooled and water cooled operation

(1) Change-over of operation between air cooled and water cooled

The unit is possible to operate on either operations of air cooled or water cooled.

During the transit on the land, in the yard or on the deck, the air cooled operation is normal, and the operation in ship holds is normally water cooled.

The operation can be changed from air cooled to water cooled and vice verce automatically by the water pressure switch; i.e. when water pressure at the inlet of the water cooled condenser rises higher than the presetting value, the contact points of the water pressure switch are cut out, so the condenser fan motors stop, and the water cooled operation starts. On the contrary, when water supply is suspended during the water cooled operation, the contact points of the water pressure switch come in contact and the condenser fan motors are rotated. Thus, the air cooled operation starts.

(2) Connecting method of the couplings for cooling water.

The cooling water pipes are connected to the inlet and outlet of the water cooled condenser with the quick coupling so that they can be connected or disconnected easily.

To accomplish the water cooled operation, the cooling water inlet and the outlet are piped and air in the water cooled condenser and the piping should be purged, and after that it is necessary to drain off all the water, according to the following instruction.

Note; During water cooled operation, fresh water shall be used as cooling water.

- Before the water cooled operation:
 1. Close the drain cock.
 2. Connect the cooling water inlet coupling.
 3. Connect the cooling water outlet coupling.
 4. Open the drain cock and purge the air.
 5. After having completed air purge, close the cock.
- After the water cooled operation:
 1. Disconnect the cooling water outlet coupling.
 2. Disconnect the cooling water inlet coupling.
 3. Open the cock and drain off water.

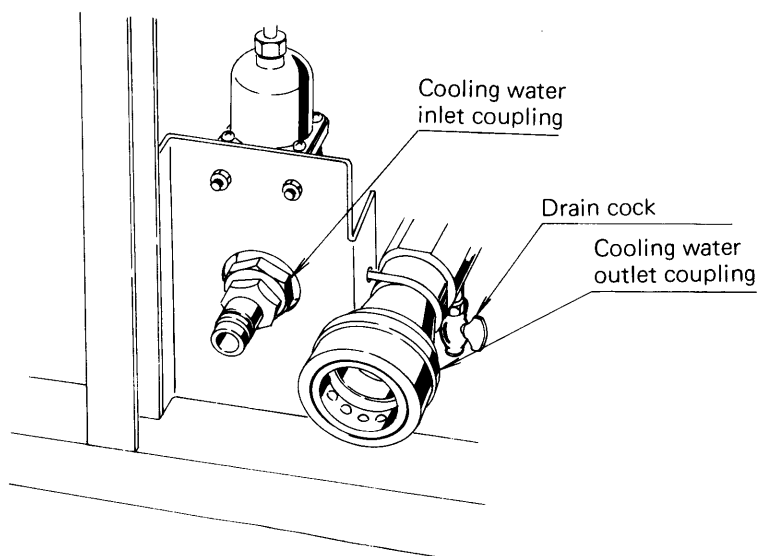

Water and drain connections

The water outlet coupling is designed to be open when connected with the other coupling but closed when separated from the other coupling so water flows when the outlet is connected, but does not flow when separated. The couplings should be connected in the order from the inlet to the outlet, coupling. When the cooling water couplings are connected, insert the coupling on the ship side into the coupling on the unit side until a “click” is heard. When disconnecting them, pull the coupling on the ship side toward you while pushing the A part of the female coupling in the direction pointed by an arrow mark.

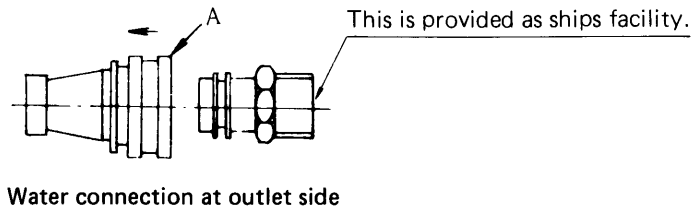

5.4 Defrosting operation

The defrosting operation is accomplished by the electric heater used for heating either manually or automatically.

When the manual defrost switch on the front of the control box is turned towards “MANUAL”, the manual defrosting is carried out.

However, when the manual defrosting switch 3D is released, it springs back from “MANUAL” to “AUTO” and the automatic operation is recovered. Further, manual defrosting is not accomplished unless temperature on the evaporator surface is 1.6°C (35°F) or less while the compressor is in operation.

The defrosting operation will be explained hereunder, so please read to refer the attached wiring diagram. The automatic defrosting is initiated by the air pressure switch for defrosting and the defrost timer. By this, the defrosting operation can be accurately accomplished even when one of them is out of order. In case the air pressure switch for defrosting 63DA functions, pressure difference before and behind the evaporator becomes large and the contact points of 63DA are closed. Since the 2DX coil is energized, the 88F coil is de-energized, the contact points are opened, the evaporator fan motor MF1 stops, pressure difference before and behind the evaporator is eliminated, the contact points of 63DA are open and the 2DX coil is self retained by means of the circuit from 23A and remains energized.

On the other hand, the 20S circuit is de-energized as the contact points of 2DX are open, so 20S is closed and pump down is started. Then the contact points of 63HL are open, the contact points of 88C are open, and the condenser fan motor MF2 and the compressor MC stop. When the 88C coil is de-energized, the contact points of 88C in the 88H circuit are closed, 88H is energized, and the electric heater H comes into operation. Thus, defrosting starts.

The defrost timer 2D functions as follows.

2D is energized at the same time when the cooling operation is started (3-88 is turned on) and counts times. If the defrosting operation starts by means of 63DA or 3D during time counting, 2D is de-energized and returned to the original state.

On completion of the defrosting operation, 2D starts counting times. If the defrosting operation will not start by 63DA or 3D within the preset period of 2D during the cooling operation, 2D starts it.

Once the defrosting operation has started, 2D is returned to its original state and is ready to start counting times on completion of the defrosting operation; i.e. 2D functions counting times after completion of the defrosting operation (Function by 63DA, 2D, 3D) as stated before.

In case the manual defrosting switch 3D is set at “MANUAL” the operation is the same as mentioned in the function of 63DA.

When defrosting is terminated, the evaporator temperature rises, and the contact points of defrost termination thermostat 23D are open. So, the 2DX coil is de-energized and the contact points of 2DX are reset as shown below, so 88H is de-energized, and the heater operation is completed. At the same time, 20S is energized, the solenoid valve is open, pump down is released, the contact points of 63HL are closed, and the unit will come into the cooling operation again. In case 63DA, 2D or 3D is turned on when the compressor is stopped by 23A, 2DX is not self-retained, so defrosting will not start. Namely the defrosting operation starts after the 20S circuit is closed by 23A. The firestat 26AH protects against unusual high heat as mentioned before in the heating operation. However, it is different from the heating operation, defrosting is carried out regardless of the temperature setting of 23A.

5.5 Pilot lamps and remote monitoring lamps

In the control box, the following three pilot lamps are mounted, and which are shown running conditions as follows.

- Greenlights up while compressor is running.
- Orangelights up while inside temp. is within the preset range.
- Redlights up during the defrosting operation.

These lamps are attached on the upper part of the access window so that they cannot be seen from the front, which means these lights are mistaken for other guard lights from the bridge.

Further, they are also used for lighting the recording chart.

In addition, the receptacle for pilot lamp is equipped to guard the operation remotely in the ship. The monitoring receptacle is located at the front of the electric kit box. Cap it when it is unused. The wiring connections to the monitoring receptacle are shown below, so provide the wiring correctly.

Monitoring receptacle for pilot lamp

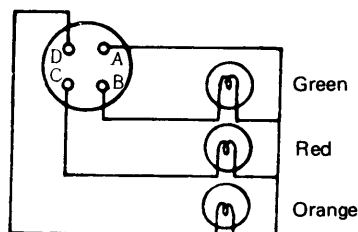

6. Periodical inspection

Inspect the each components in the unit periodically as it works in good condition, and adjust or repair them if it is necessary.

Container refrigeration unit inspection card

Installed ship name				Date of inspection		
Container No.				Place of inspection		
Loaded cargo		Loaded or none		Unit Model No.		
Customer's staff				Unit No.		
Service staff				Compressor No.		
Check	No.	Check point		Check method	Reference value	
	1	External appearance of important parts of container (doors, equipment mount, damaged points)		Visual		
	2	Cleaning interior and exterior of container		Visual		
	3	Checking the smudge of the unit (air-cooled condenser, evaporator)		Visual		
	4	Checking "through" points inside and outside unit		Visual		
	5	Checking for leakage from refrigerant system (joints)		Halide torch		
	6	Checking external appearance of power cable and plug		Visual		
	7	Cleaning drain hose		Visual	Shall be free from clogging	
	8	Cleaning defrost air hose and checking to ensure that there is no trap		Visual	Shall be free from clogging	
	9	Mounted condition of electric heaters		Visual	Make sure that leads are not in contact with heaters	
	10	Checking exterior of firestat		Visual	Shall have no damaged part	
	11	Tightened condition of cable glands and monitoring receptacle		Retighten with tool	Make sure that they are firmly tightened	
	12	Checking condenser and evaporator fan motors for vibration and noise		Touch and listen		
	13	Checking amount of circulating refrigerant		Check liquid indicator	Make sure that it is sealed	
	14	Checking for water in refrigerant		Check liquid indicator	Green	
	15	Checking compressor oil level (operating condition)		Check compressor oil level gauge	⊖ (oil level 1/4 - 3/4)	
	16	Confirm the function of the watch of the temperature recorder and the life of the battery.		Confirm it from the rotary access window and the remaining V indicator.		
	17	Checking to ensure that recording thermostat has been calibrated (at storage temperature of 0°C)		Measuring temperature with a thermistor		
	18	Checking operation of recording thermostat and pilot lamps		Move temperature setting knob and check		
	19	Checking operation of defrost initiation air switch		Check with U tube	20 ± 2 mmH ₂ O CUT IN	
	20	Unit operating current R <input type="checkbox"/> S <input type="checkbox"/> T <input type="checkbox"/>		Clamp meter	-18°C <input type="checkbox"/> V <input type="checkbox"/> Hz	
	21	Unit insulation resistance	Compressor circuit <input type="checkbox"/> MΩ	DC 500V megger	2MΩ or more	
			Electric heater circuit <input type="checkbox"/> MΩ			
			Evaporator fan circuit <input type="checkbox"/> MΩ			
	22	Checking manual defrosting operation		Manual defrost switch		
	23	Checking operation of defrost termination thermostat (Completing temperature) <input type="checkbox"/> °C		Mount thermistor to completion thermostat mounting position	OFF 7.2 ± 1.7°C	
	24	Electric heater operation and current R <input type="checkbox"/> S <input type="checkbox"/> T <input type="checkbox"/>		Clamp meter		
	25	Checking operation of dual pressure switch	H-CUT OUT <input type="checkbox"/> kg/cm ²	Operate the air cooled condenser without fan operation	20 kg/cm ²	
			L-CUT OUT <input type="checkbox"/> mmHgV	Accomplish pump down by use of the stop valve at the water cooled condenser outlet	400 mmHgV	
			L-CUT IN <input type="checkbox"/> kg/cm ²		0.2 kg/cm ²	
	26	Checking power supply changeover switch	Checking 400V class operation	Place changeover switch lever upward		
			Checking 200V class operation	Place changeover switch lever downward		
	27	Storage temperature °C	<input type="text"/>	0°C	-18°C	Automatic operation at -18°C
		Ambient temperature °C	<input type="text"/>	<input type="text"/>	<input type="text"/>	<input type="text"/> in one cycle
		LP kg/cm ²	<input type="text"/>	<input type="text"/>	<input type="text"/>	COMP OFF <input type="text"/> M
		HP kg/cm ²	<input type="text"/>	<input type="text"/>	<input type="text"/>	COMP ON <input type="text"/> M
		Operating time	Immediately after operation	Operation <input type="text"/> °C <input type="text"/> Hr <input type="text"/> M	Operation <input type="text"/> -18°C <input type="text"/> Hr <input type="text"/> M	Automatic operation at -18°C <input type="text"/> Hr <input type="text"/> M
		Operation starting time <input type="text"/>				
	28	Checking automatic defrosting operation		Defrost time <input type="text"/> M		

7. Inspection and adjusting method

7.1 Electronic recording temperature controller

1. Specifications

Model : WKM-S424Q

1.1 Electronic controlling parts

- Power source AC 24V 50/60Hz
- Temperature control range $-25 \sim +25^{\circ}\text{C}$ ($-13 \sim 77^{\circ}\text{F}$)
- Sensor Platinum temperature measuring resistant body (0°C (32°F) 100Ω)
- Number of output switches 4 ea
- Characteristics of switch function **Example:** Temperature setting standards will be -2°C when sensing temperature and setting temperature are 0°C and 2°C respectively.

Temperature setting standards
(Sensor temp.) – (Temperature setting)

Temp.		Temp.														
		-7	-6	-5	-4	-3	-2	-1	0°F	1	2	3	4	5	6	7
Name		Name														
		-4	-3	-2	-1	0°C	1	2	3	4						
COMP.		0°C (OFF) ←														
		→ 1.1°C (ON)														
IN RANGE		← -3.6°C (OFF)														
		→ -2.5°C (ON)														
HEATER	Setting Temperature more than $-4.5 \pm 1^{\circ}\text{C}$ [$24 \pm 2^{\circ}\text{F}$]	← -1.5°C (ON)														
	Setting Temperature lower than $-6.5 \pm 1^{\circ}\text{C}$ [$24 \pm 2^{\circ}\text{F}$]	→ -0.4°C (OFF)														
MANUAL	Setting Temperature more than $-4.5 \pm 1^{\circ}\text{C}$ [$24 \pm 2^{\circ}\text{F}$]	ON														
	Setting Temperature lower than $-6.5 \pm 1^{\circ}\text{C}$ [$24 \pm 2^{\circ}\text{F}$]	OFF														

- Difference between ON and OFF of switch (diff): 1.1°C (2°F)
- External wiring (Wiring from the devices in the control box to the unit body . . . to Terminal 21 in Fig. 1)

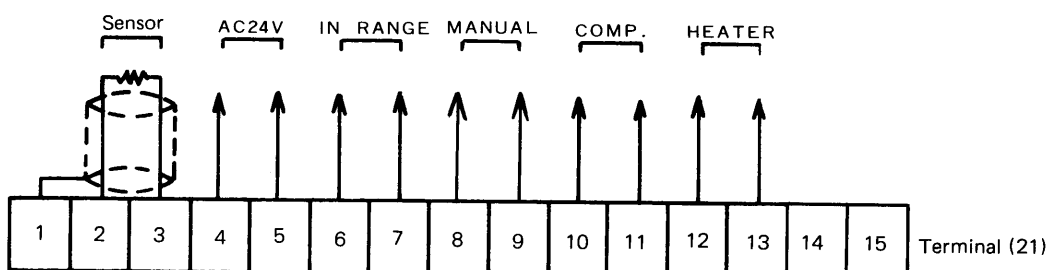

- Insulation resistance Over $50\text{ M}\Omega$ with DC 500V meger
 - Insulation strength for 1 minute with AC 500V
- Note:** Do not impress voltage on the sensor terminals 1, 2, and 3.

1.2 Recording part

- Feeler tube
- Recording method
- Recording temperature range
- Recording paper

Gas sealed

Pressure sensing type

-25 ~ +25°C (-13 ~ 77°F)

Dia. 203 Disk type pressure sensible paper
(Graduation 1/1°C)

(Corresponding to PSD-217C (REV. A) made of PARTLOW Co.)

Timer (Quartz motor + reducing gears) a turn/31 days

- Driving method for recording paper

Goods corresponding to Dry battery

(DC 1.5V) JIS C 8501 SUM2

IEC R14

Quartz Motor Driving source:

Life is approx. 1 year (Remaining voltage indicator)

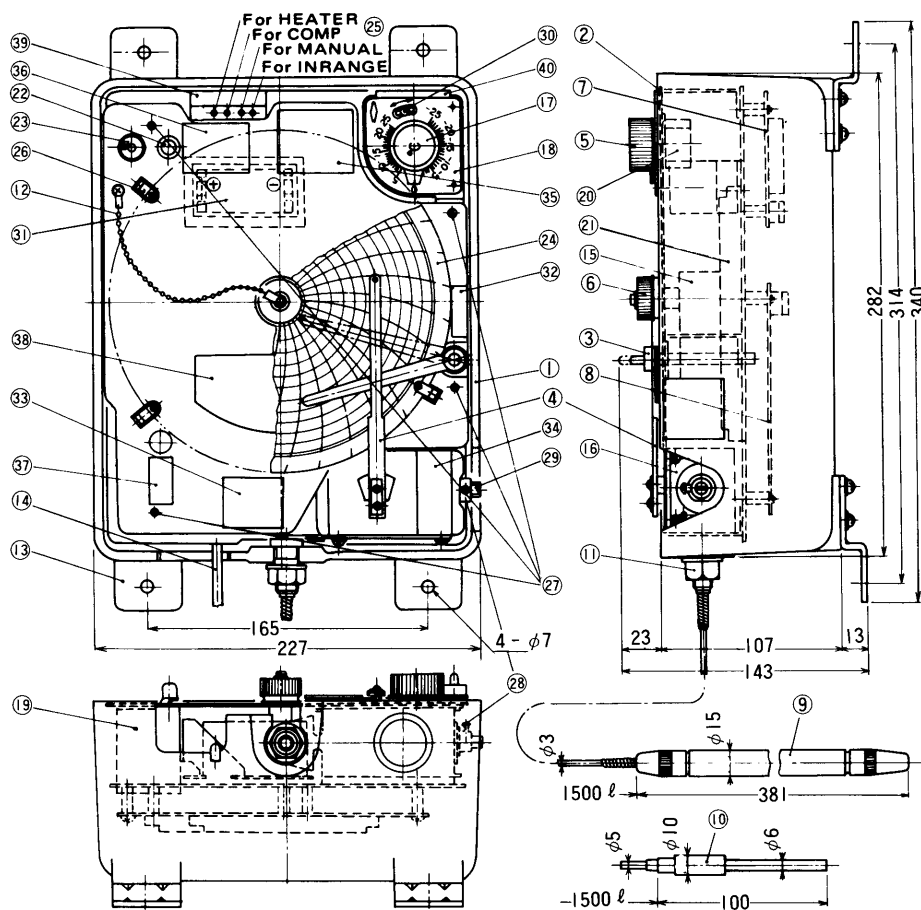

Fig. 1 Structure

- | | | |
|------------------------|--|--|
| (1) Case | (16) Element | (30) Fine adjusting screw for functioning temp. |
| (2) Recording board | (17) Name plate for setting knob | (31) Dry battery |
| (3) Pen lifting arm | (18) Setting name plate | (32) Present time plate |
| (4) Pen | (19) Diapason motor | (33) Instruction plate for pen operation |
| (5) Setting knob | (20) Volume | (34) Instruction plate for recording temperature adjustment |
| (6) Chart nut | (21) Terminal strip | (35) Instruction plate for controlled temperature adjustment |
| (7) Relay plate | (22) Push switch | (36) Instruction plate for battery checker |
| (8) Main base plate | (23) Remaining V indicator | (37) Instruction plate for starter |
| (9) Feeler tube | (24) Recording paper | (38) Wiring diagram |
| (10) Nickel sensor | (25) Function: | (39) Function indication plate |
| (11) Hexagonal nut | Pilot lamp for functioning temperature | (40) Set plate for volume setter |
| (12) Ball chain | (26) Claw for record paper | |
| (13) Mounting bracket | (27) Set screw for recording board | |
| (14) Sensor lead wires | (28) Rock screw | |
| (15) Mounting bracket | (29) Temperature indication screw | |

2. Operation points

2.1 Electronic controlling parts

2.1.1 Temperature setting

Turn the setting knob (5) to set its red line at desired temperature, at which the compressor is stopped by the compressor switch. The other switches will come into operation depending on difference between temperature setting and sensor temperature in accordance with the functional characteristics of Article 1.

2.1.2 Confirmation of switch function

When the power source for the unit is turned on, the switch will function in accordance with Article 1.1. For confirmation of switch function, see the pilot lamp (25) (Function temperature indication lamp).

The pilot lamps are arranged in the order from the top, lamp for HEATER lamp for COMP for MANUAL and lamp for IN RANGE. (See Function Plate (39)).

2.2 Recording parts

2.2.1 Removing the recording plate

- (1) Turn the pen holding arm (3) by approximately 30° clockwise towards 5 O'clock by pressing it and release it, and the pen is suspended.
(The location of the arm is shown with dotted line in Fig. 2)
- (2) Loosen four set screws (27) for recording board and the chart nuts (6), and remove the recording board to the A direction. The set screws (27) cannot be removed from the recording board to prevent them from being lost.

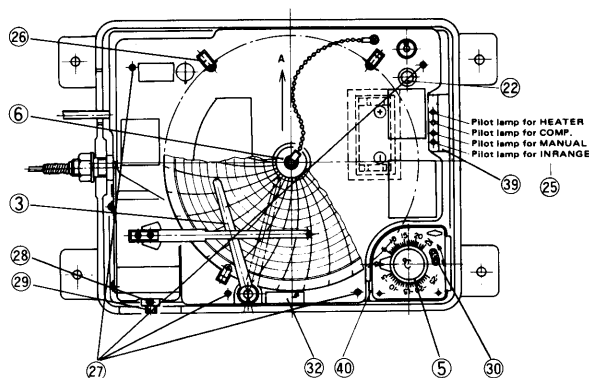

Fig. 2

2.2.2 Recording paper set

- (1) Set the recording paper in the centre hole in such a way that it is inserted among three set claws (26), volume setting board (40) and the recording board. At this time, note that the periphery of the recording paper does not roll up.
- (2) Set a date on the recording paper (32) at the arrow mark on the present time plate. Firmly press the recording paper and tighten up the chart nut (6).
- (3) Turn the pen holding arm (3) counterclockwise by pressing it. (The arm is located as shown with solid line in Fig. 2). At this time, confirm that the pen lifting arm is fixed.

2.2.3 Driving part of recording paper

The recording paper is driven by the timer which is composed of a quartz motor and reducing gears. The quartz motor is driven by a dry battery.

- (1) Checkout of remaining voltage of dry battery
Press down the push switch (22) to check life of a dry battery; i.e. check that the needle of the remaining voltage indicator is within blue zone. (The meter is functioning while the push button is pressed down)



- (2) Checkout of the quartz motor function
After having checked remaining voltage of the dry battery, check from the access window that flywheel inside is turning.

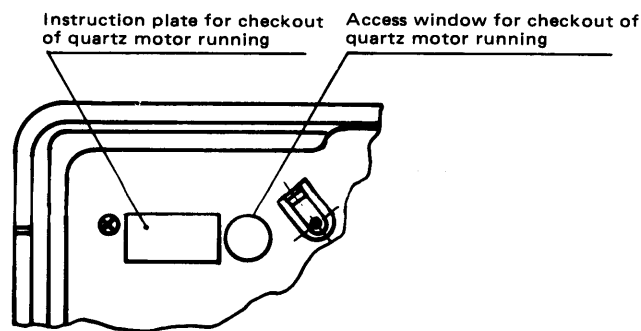

3. Inspection and adjusting method

3.1 Electronic controlling part

3.1.1 Inspection points

- (1) Set the temperature setting knob at 0°C (32°F) and put the unit into refrigeration operation.
- (2) Accomplish inspection after storage temperature becomes even after repeating compressor operation on and off more than three times.
- (3) When the compressor switch is turned off (Pilot lamp (25) goes off – see Article 2.1.2) or the solenoid valve is turned off, measure storage temperature with the thermistor thermometer and confirm that it is within $0 \pm 1^\circ\text{C}$ ($32^\circ\text{F} \pm 2^\circ\text{F}$).
- (4) Confirmation of other switches
After having confirmed the compressor switch as stated in (3), operate the unit for a few minutes with its setting 0°C (32°F). When the compressor switch or the solenoid valve is turned off, confirm functioning temperature of each switch when the temperature setting knob (5) is turned by reading temperature indicated by the red line on the knob.
- (5) Confirm functioning temperature in the following order. Turn the temperature setting knob as stated below.
 - (a) Gradually raise temperature from -10°C (-14°F).
 - (b) Gradually decrease temperature from $+10^\circ\text{C}$ ($+50^\circ\text{F}$).
- (6) Confirm that functioning temperature of each switch (by pilot lamp (25)) becomes as tabulated below by doing as stated in the above (a) and (b).

Name		Temperature setting													
		-7	-6	-5	-4	-3	-2	-1	0°F	1	2	3	4	5	6
Temp.		-4	-3	-2	-1	0°C	1	2	3	4	5	6	7	8	9
a	COMP.			ON				OFF (0°C)			OFF				
	IN RANGE	OFF		ON (-2.5°C)								OFF (3.6°C)			OFF
	HEATER				OFF					ON (1.5°C)			ON		
b	COMP.			ON			ON (-1.1°C)			OFF					
	IN RANGE	OFF	OFF (-3.6°C)			ON					ON (2.5°C)		OFF		
	HEATER			OFF				OFF (0.4°C)				ON			

Notes:

1. Tolerance of switch function is $\pm 1^{\circ}\text{C}$ ($\pm 2^{\circ}\text{F}$) (Based on Comp. switch is turned OFF, and 0°C)
2. In case confirmation (b) is accomplished in succession of (a), wait until storage temperature becomes stable by operating the unit with storage temperature setting at 0°C (32°F), as storage temperature is raised in the process of confirmation (a).
3. For confirmation of function of the MANUAL switch and the fixed switch for HEATER, manipulate the temperature setting knob up and down when storage temperature is -10°C (14°F).
 - When the knob is pressed downward, the MANUAL switch and the switch for HEATER is turned OFF from ON at $-6.5 \pm 1^{\circ}\text{C}$ ($20 \pm 2^{\circ}\text{F}$).
 - When the knob is pressed up, the MANUAL switch and the switch for HEATER is turned ON from OFF at $-4.5 \pm 1^{\circ}\text{C}$ ($24 \pm 2^{\circ}\text{F}$)

3.1.2 Adjusting method

If functioning temperature differs with temperature setting, adjust as stated below.

- (1) Set the setting knob at 0°C (32°F) and put the unit into refrigeration operation. After storage temperature becomes even, accurately measure storage temperature with the thermistor thermometer when the compressor switch or the solenoid valve is turned OFF.
- (2) Loosen the fine temperature control adjusting screw (30) and move the screw along the longitudinal hole as shown on the right, and then the red line on the setting knob moves accordingly. Set the red line at the temperature measured as in (1), and carefully tighten up the adjusting screw (30). (When the setting knob is tightened up, note it does not move) (Ex. When storage temperature setting is 0°C , if actual storage temperature is 0°C when the compressor switch (or the solenoid valve) is turned OFF, set the red line of the setting dial at 1°C .)
- (3) After completion of adjusting, inspect the unit in accordance with Article 3.1.1.

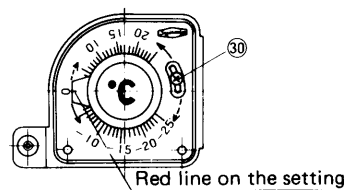

3.2 Recording part

3.2.1 Inspection points

Inspect the following recording part after having inspected and adjusted the electronic controller as stated in Article 3.1.

- (1) Set the setting knob at 0°C (32°F), and put the unit in the refrigeration operation for over three hours, and then confirm that storage temperature becomes equal to 0°C (32°F). Then confirm that indication temperature of the pen is 0°C (32°F) immediately after the compressor switch (or the solenoid valve) is turned off.

Note: Inspection for short period operation

In case an inspection is accomplished after having ON/OFF operation several times from the pull-down operation, there must be time lag in recording, confirm that indication temperature of the pen is 0.5°C (33°F) when the compressor switch (or the solenoid valve) is turned off at storage temperature at 0°C (32°F), and after a lapse of time, indication becomes 0°C .

3.2.2 Adjusting method

- (1) Accomplish adjustment in succession of the inspection described in Article 3.2.1.
- (2) Adjustment is accomplished by turning the temperature setting screw (29). Loosen the lock screw (28) and turn the setting screw (29) clockwise so that temperature setting is approximately under 5°C (41°F). Then, turn the setting screw (29) counterclockwise to reduce temperature indication of the pen to 0°C (32°F) (In case of short period operation, down to 0.5°C (33°F). Then, tighten up the lock screw (29) after adjustment.)

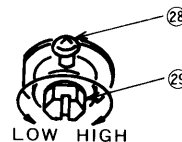

Notes:

1. A turn of the setting screw (29) changes temperature indication by approx. 5°C (9°F).
2. Temperature indication may be changed a little when the lock screw (28) is tightened up.

4. Replacement of parts

(Note: Replace parts after turning off the power source)

4.1 Before replacing other parts, removing method of the internal device assembly is explained.

- (1) Remove the recording plate from the body (1) (See Article 2.2.1) When it is removed, it looks as shown in Fig. 3. In this state, sensor, timer, remaining voltage indicator and batter and dry battery are replaced.
- (2) Remove the internal device assembly. Loosen four hexagonal nuts (11) and screws (46) and remove the internal device assembly from the main body (1) and turn it back. Then it looks as shown in Fig. 4.

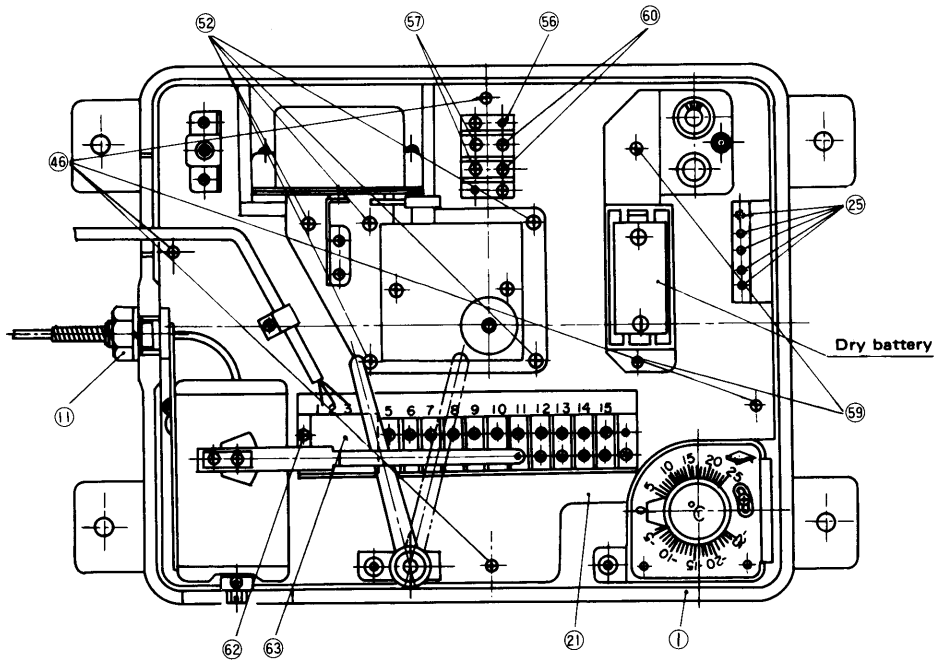

Fig. 3 Internal structure

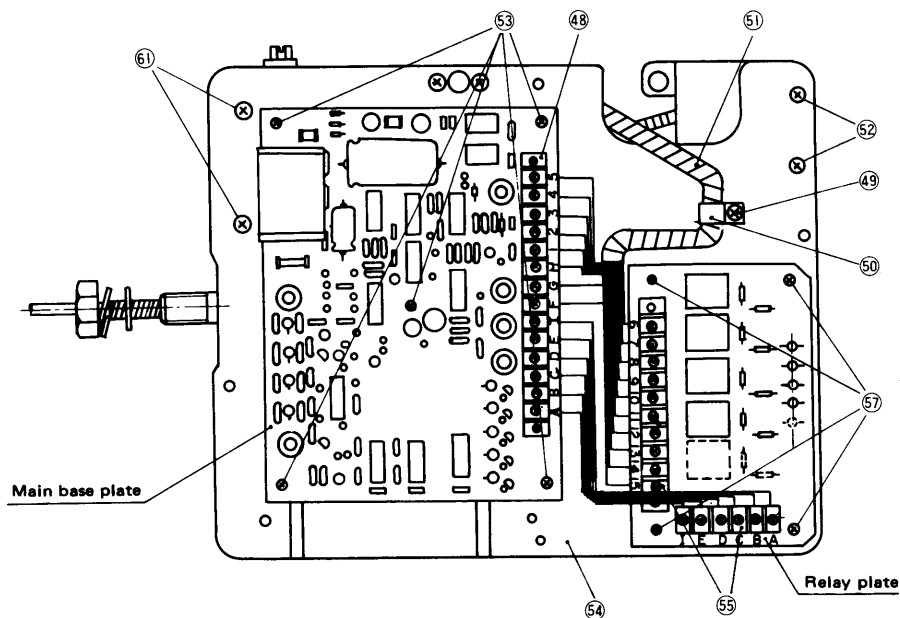

Fig. 4 Internal device assembly

4.2 Electronic controlling parts

4.2.1 Volume setter

(1) Replacing standards

- In case functioning volume of the compressor switch cannot be adjusted as stated in Article 3.1.2.
- In case switches other than the compressor switch cannot be adjusted to function at the standard values.
- In case all the pilot lamps for functioning temperature do not light up although the power source switch is turned on. (If this phenomenon takes place, confirm the function of sensor in accordance with Article 4.2.4, and if no trouble is found with the sensor, apply this)
- In case switch function remains unchanged although setting of the volume setter is changed by the adjusting knob.

In the case of the above phenomena, measure resistance of the volume setter (in accordance with Article 2) and if it is out of the predesigned volume, replace the volume setter with a new one. If it is within the predesigned value, the main base plate must be out of order, so replace it in accordance with Article 4.2.2.

(2) Measuring resistance of the volume setter

- Adjust the volume setter as shown in Fig. 4 in accordance with Article 4.1.
- Remove the lead wires (3 pcs, F. G. H.) which are laid from the volume setter from the terminal (48) (13P) on the terminal strip of the main base plate and measure resistance between G and H of the lead wires.
- Confirm that resistance between G and H is within the values tabulated below at the predesigned temperature.

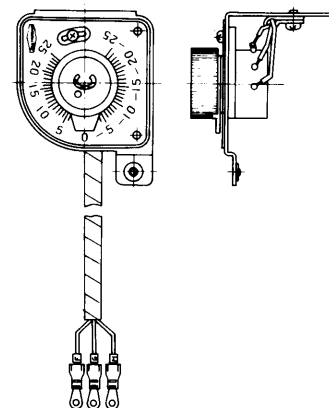

Fig. 5 Volume setter (WKM-AA005)

Temperature setting	Predesigned resistance
In case of -25°C	162 ~ 198 Ω
In case of 0°C	2250 ~ 2750 Ω
In case of 25°C	4132 ~ 5033 Ω

(3) Replacing points

- In case resistance is out of the predesigned value, replace the volume setter.
- From the state of the volume setter as shown in Fig. 4, loosen screw (49), remove power source plug (50), remove the spiral tube (51) from the wires. Then remove two screw bolts (52) and the volume setter can be removed from the base (54).
- After replacing the volume setter with a new one, inspect and adjust it in accordance with Articles 3.1.1 and 3.1.2.

4.2.2 Main base plate

(1) Replacing standards

- In case the volume setter shows the phenomena as stated in Article 4.2.1. Replacing standards and yet it has no trouble or the same phenomena take place after replacing the volume setter.

(2) Replacing points

- Adjust the volume setter as shown in Fig. 4 in accordance with Article 4.1.
 - Remove the wires (13 pcs Nos A ~ H, 1 ~ 5) from the terminal strip (48) on the main base plate.
 - Remove 5 screws (53) to remove the base (54) from the main base plate, so replace it with new one.
- After replacement, inspect and adjust it in accordance with Articles 3.1.1 and 3.1.2.

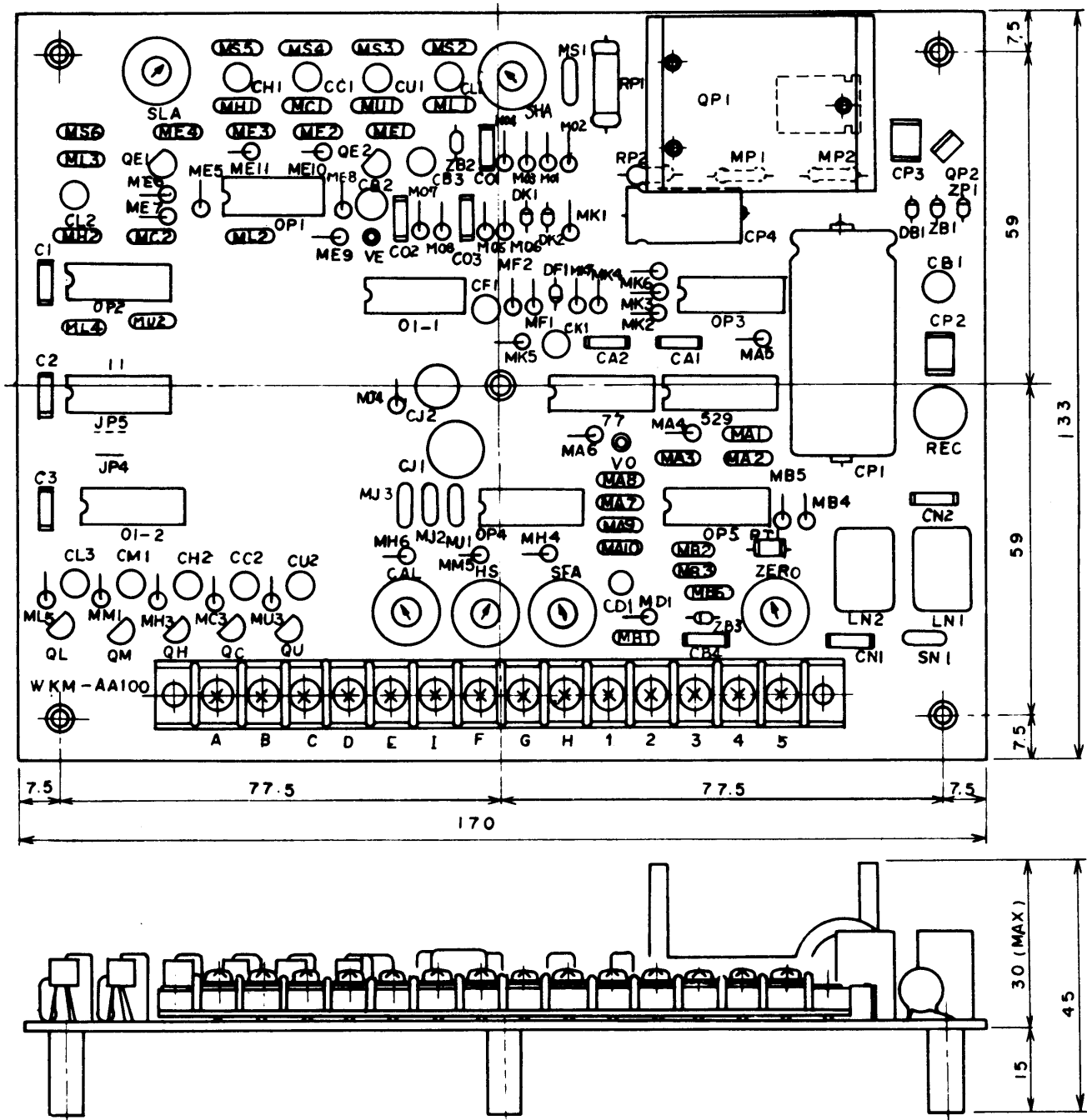

Fig. 6 Main base plate (WKM-AA100)

4.2.3 Relay base

(1) Replacing standards

- The pilot lamp for functioning temperature lights on and off, but the switch does not come into operation.

(2) Replacing points

- Adjust it as shown in Fig. 4 in accordance with Article 4.1.
- Remove the wires (13 pcs No. A ~ E, 6 ~ 13) from the terminal strip (55) on the relay base plate.
- Loosen four screws (57), and the relay base plate can be removed from the base (54). So replace the relay base plate with a new one.
- Check the pilot lamp and the switch for their functions after replacement.

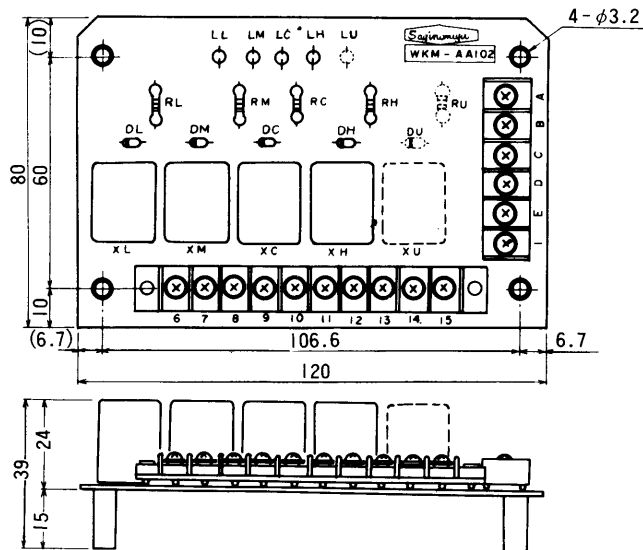

Fig. 7 Relay plate (WKM-AA102)

Note: Lay the wiring correctly in accordance with Fig. 8 when the main base plate and the relay plate are replaced.

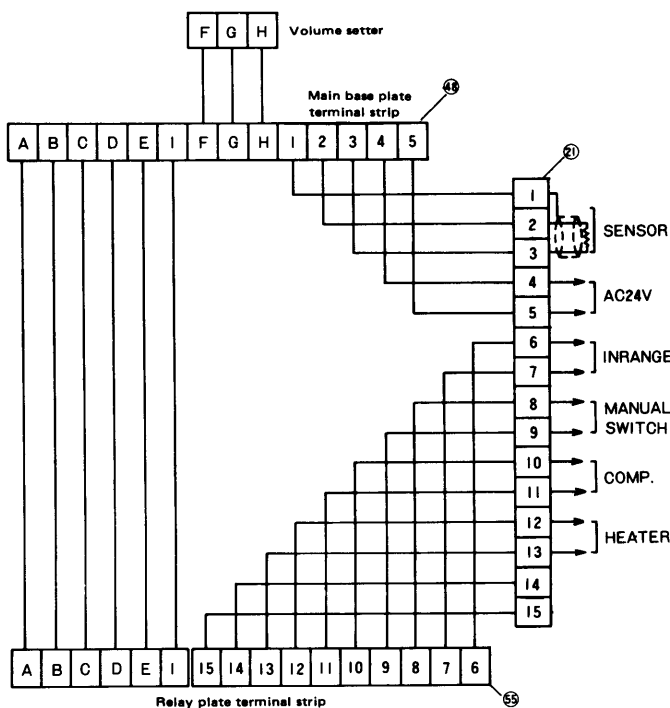

Fig. 8 Internal wiring diagram

4.2.4 Sensor

(1) Replacing standards

- In case the pilot lamps for functioning temperature (25) remain unlit although the power source is turned on.
- In this case, turn the temperature setting knob within $+25 \sim -25^{\circ}\text{C}$ and confirm that the pilot lamps light up. If one of the pilot lamps lights up, the sensor is correct. In case all the lamps remain unlit, measure resistance of the sensor as follows.
- Remove the recording board, (state shown in Fig. 3). Loosen the screws (62) to remove protection board for impressed voltage (63) loosen terminal screws (Nos. 1 to 3) on the terminal strip (21) and remove the wiring. Then, measure temperature of the feeler part and resistance of the sensor and compare them with the characteristics of temperature resistance shown in Fig. 10, and if they do not accord with them, replace the sensor. If they accord, the main base plate or the volume setter is out of order. So replace it in accordance with Articles 4.2.1 and 4.2.2.

(2) Replacing method

- Since numbers (1, 2, 3. . .) are described on the sensor lead wires, so connect them to the terminals having the same number on the terminal strip (21).
- After replacement, inspect and adjust the sensor in accordance with Articles 3.1.1 and 3.1.2.

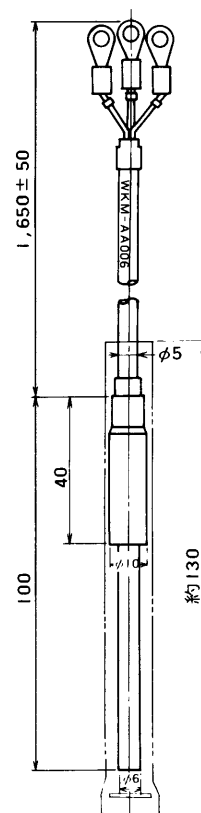
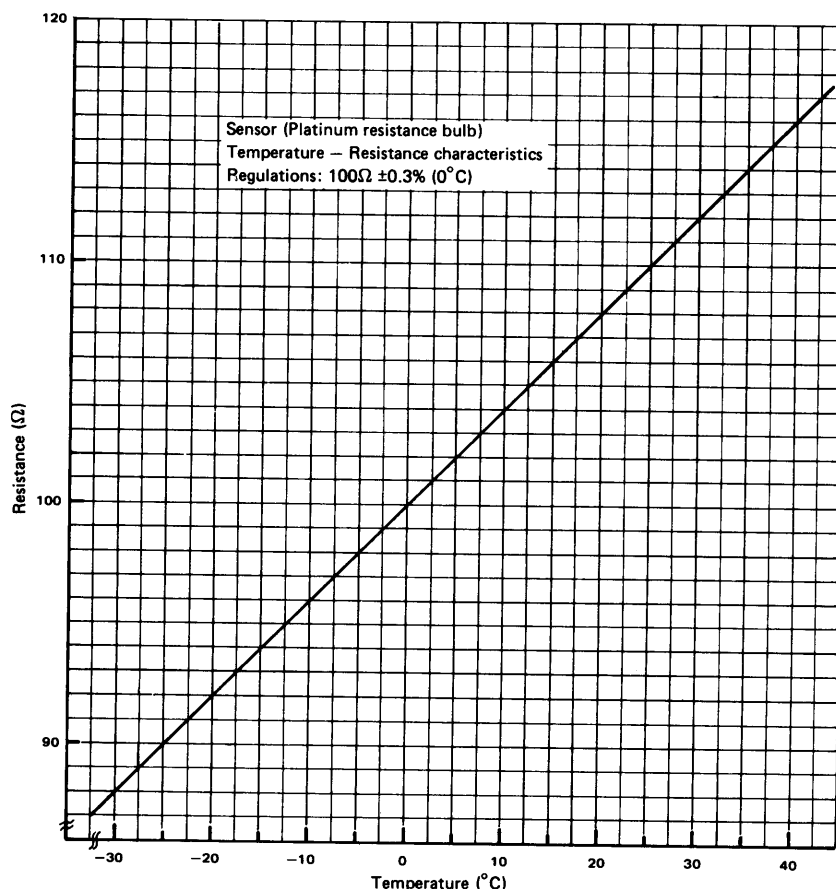

Fig. 9 Sensor (WKM-AA006)

Fig. 10



4.3 Recording part

4.3.1 Dry battery

(1) Replacing standards

- According to Articles 2.2.3, confirm remaining voltage of a dry battery. If the needle of the indicator is out of the blue zone, replace the battery. (In case the indicator needle is within the white zone or above the dotted line in the figure on the right, life of battery may last approximately a month)

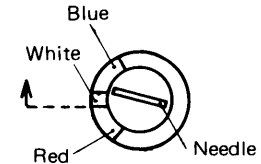

Remaining V indicator

(2) Replacing method

- Replace the recording board, and insert a battery so as not make a mistake in polarity as in the state of Fig. 3 (Fig. 3 shows polarity of a battery). It is advisable to use a battery similar to SUM-2 of JIS C8501 and R14 of IEC. (Dry battery DC1.5V)
- After replacement, confirm that the remaining voltage indicator is still within the blue zone and also confirm that the motor is running.

4.3.2 Remaining voltage indicator battery

(1) Replacing standards

- In case oscillation of the needle is unstable when the push switch is pressed down for confirmation of remaining voltage.
- In case the remaining voltage indicator needle is within the white zone or in the red zone, although a new battery is set in.

(2) Replacing method

- Remove the recording board (state shown in Fig. 3). Loosen two screw bolts (59) and two screw bolts (60), and the remaining voltage indicator battery can be removed from the indicator body. So replace it with a new battery.
- When replacing, connect the wires to the terminal strip (56) in a way red wire to red and black wire to black.
- After replacing, insert a dry battery and then confirm that the needle of the remaining voltage indicator is within the blue zone and the quartz motor is running.

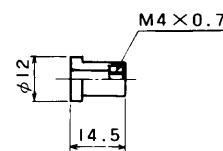
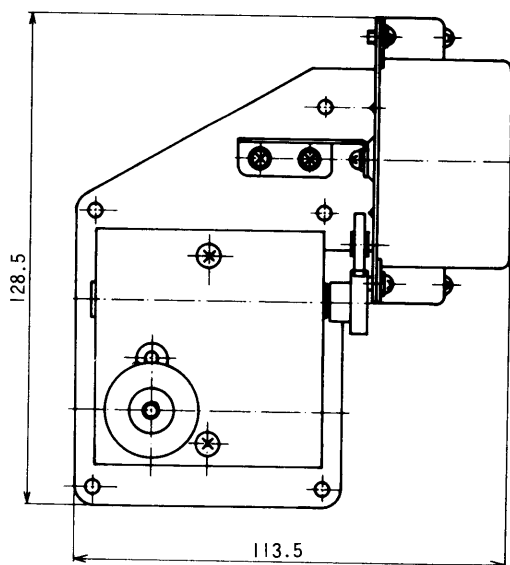

Accessory (Vibration protection rubber 5)

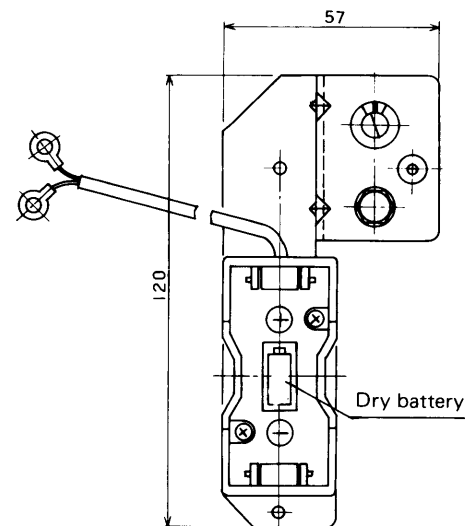

Fig. 11 Remaining voltage indicator - Battery (WKM-AA013)

Fig. 12 Timer (Quartz motor reducing gears) (WKM-AA012)

4.3.3 Timer (Quartz motor reducing gears)

(1) Replacing standards

- Although remaining voltage of dry battery is correct (confirmed in accordance with Article 2.2.3), the quartz motor does not start.
- In case time dealy is over 3 hours per day.

(2) Replacing method

- Remove the recording board (state shown in Fig. 3). Loosen two screw bolts (57) from the terminal strip (56) to remove the wires. Then remove five screw bolts (58) to replace the timer with a new one.
- When replacing the timer, replace the attached vibration protective rubbers (5 pcs) at the same time. The red wires are for + current and the black wires – current. Connect the wires to the terminal strip (56) in a way that red wires are connected to red and the black wires to black. Tightening torque for vibration rubber is 4 ~ 5 kg-cm.
- After replacement, confirm that the quartz motor is running.

4.3.4 Feeler tube – element

(1) Replacing standards

- After having adjusted the recording part in accordance with Article 3.2.2, operate the unit with temperature setting within $-18 \sim +10^{\circ}\text{C}$ ($-0.4 \sim 50^{\circ}\text{F}$). If temperature indication differs from temperature setting by over 2°C (4°F) although storage temperature becomes stable to its temperature setting. (In case temperature indication is minus far from feeler tube temperature, gas may leak from the feeler tube)

(2) Replacing method

- Take out the internal assembly as stated in Article 4.1 and turn it inside out, which is shown in Fig. 4.
- Loosen two screw bolts (61) to remove the feeler tube – element and replace it with new one.
- After replacement, inspect and adjust it in accordance with Article 3.2.

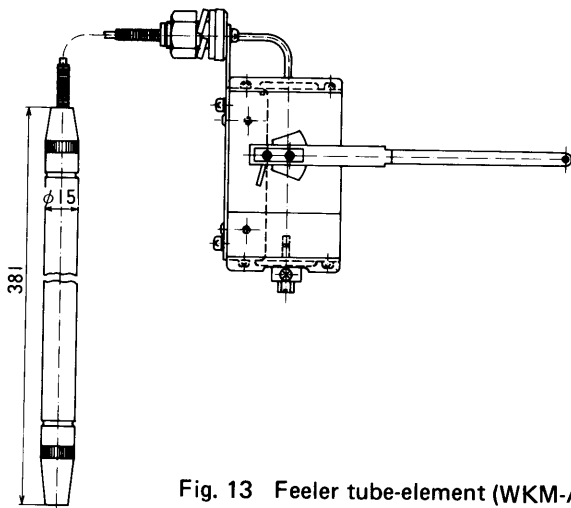

Fig. 13 Feeler tube-element (WKM-AA011)

5. Caution for handling

- 5.1 Be careful not to pull the sensor lead wires and capillary tube forcibly.
- 5.2 Do not bend the capillary tube with less than R50.
- 5.3 Do not give any impact to the sensing part of the sensor.
- 5.4 Do not give torque larger than 5 kg-cm onto the temperature setting knob.
- 5.5 Insulation test should be done with numbers from 4 to 15 on the terminal strip (21) (Fig. 3). Do not impress voltage on the sensor terminals of 1, 2 and 3.
- 5.6 After having replaced a recording paper, check that the pen holding arm is fixed (as shown with (3) located on the solid line on Fig. 1)
- 5.7 At the time of ex-factory, protection tube covers sensor as shown in Fig. 9 with dotted line to protect impact force.
Remove the protection tube in operation, otherwise the unit does not control container temperature accurately.

6. Trouble and countermeasures

If the unit is out of order, trace a cause of trouble and take appropriate countermeasures.

State of trouble	Phenomenon	Cause of trouble (Proceed with from top to bottom)	Inspection	Countermeasures
1. Unit is inoperative	Pilot lamps for switches remain unit.	Power source (AC 24V) is not input.	Inspect power source.	
		Storage temperature is already dropped to its temperature setting.	Turn temperature setting knob within $-25 \sim +25^{\circ}\text{C}$	If lamps and relay function, there is no trouble with unit.
		Sensor is disconnected or short-circuited.	Measure resistance of sensor.	Replace volume setter.
		Trouble with volume setter.	Measure resistance of volume setter.	Replace volume setter.
		Trouble with main base plate.		Replace main base plate.
	Pilot lamps for switches light up (For comp.)	Trouble with relay palte.		Replace relay plate.
2. Relay functioning temperature incorrect	Functioning point of compressor switch cannot be adjusted or if it can be adjusted, functioning points of other switches get out of their standards.	Trouble with volume setter.	Measure resistance of volume setter.	Replace volume setter.
		Trouble with main base plate.		Replace main base plate.
3. Record paper does not rotates	Quartz motor is in operation.	Chart nut is not tightened up.		Tighten up chart nut.
	Quartz motor stops.	Dry battery is used up.	Check dry battery for remaining voltage.	Replace dry battery.
		Trouble with timer.		Replace timer.
4. Remaining voltage indicator is faulty	<ul style="list-style-type: none"> When push switch is pressed down, oscillation of indication needle is unstable. Although new battery is mounted indication needle is within white or red zone. 	Trouble with remaining voltage indicator.		Replace remaining voltage indicator.
5. Time delay in recording paper	Time is delayed over 3 hours per day.	Trouble with timer.		Replace timer.
6. Recording temperature is wrong	Although recording temperature is adjusted at 0°C , indication temperature is wrong when rechecking.	Trouble with feeler tube-element.		Replace feeler tube – element.

7. Thermistor for storage temperature

A thermistor is installed for measuring storage temperature. Its feeler part is attached to the feeler tube of the recording temperature controller so that temperature of the same position can be detected. The other end of the thermistor forms a connector which is located above the electric kit box as shown on the right. If it is connected to the thermometer, temperature at the feeler part of the thermistor can be measured.

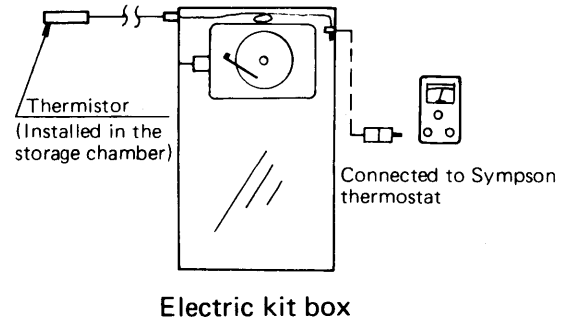

The thermistor uses the following thermometer

Maker	Type	Temperature range
Simpson Electric Company (U.S.A.)	385-2	-50 ~ +70° F

Notes: 1) Adjustment of Simpson thermometer

Turn the adjusting screw so that the meter indicator points at 0°C (32° F) when the change-over switch is set at READ in ice water whose temperature is stable at 0°C. Then set the change-over switch at ADJ and confirm that the indicator reading is 0°C (32° F). If it is not 32° F, remove the rear cover and adjust the adjusting screw located under the dry batteries to make the indicator point at 0°C (32° F).

2) In case Sympson thermometer is not available.

When the cap is removed from the fresh air intake attached to the lower access door (On the left side viewed from the front), a hole can be seen. Insert a thermometer into the hole to measure storage temperature.

7.2 Air pressure switch for defrost initiation

The air pressure switch has been precisely set at the factory. So do not change the setting unnecessarily. As for resetting, do it as follows.

- (1) Before checking the set value, be certain that the high and low pressure hoses are not broken, damaged or clogged.
- (2) When the operation value is larger than the set value, turn the adjusting screw counterclockwise.
- (3) When the operating value is smaller than the set value, turn the adjusting screw clockwise.

Adjusting method

- (a) Set the three way valve for high and low pressure of the air switch as follows.

Note: Be sure to put together to the set point when the three way valve (directional control valve) is set.

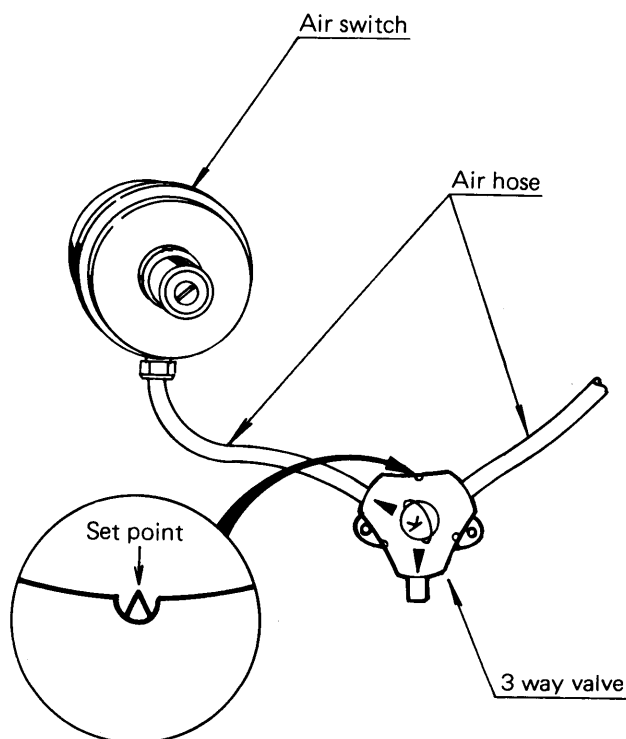

- (b) Remove two lead wires from the electric kit box and connect them to a test lamp or a tester.
- (c) Connect the air switch adjuster shown below to the three way valve (on high pressure side).

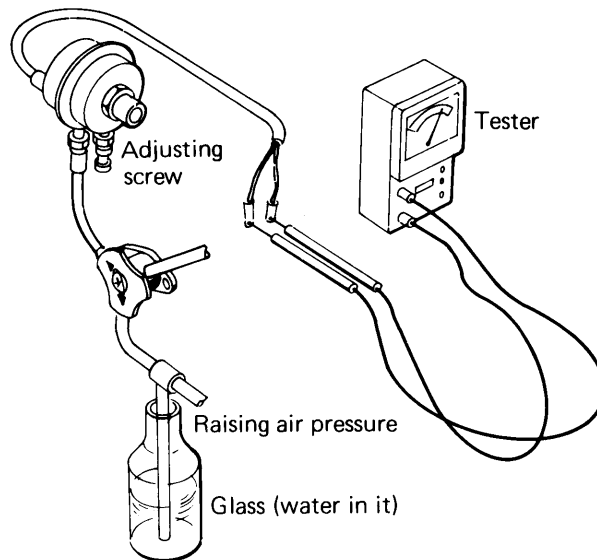

- (d) Place a test tube in a container containing water, and gradually raise pressure in a way that air bubbles are generated in it.
- (e) Read ΔH (following fig.) when the lamp lights up or the tester is energized, and confirm that value added $5\text{mmH}_2\text{O}$ to the reading is within the allowance of the setting.

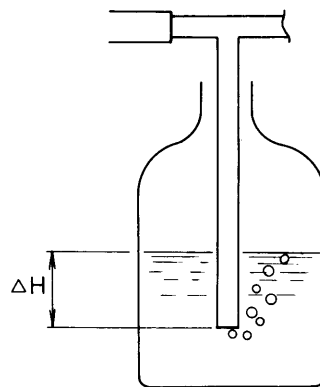

- (f) When ΔH is out of the setting allowance, adjust the adjusting screw so that ΔH is within the setting allowance, repeating the process from (d) to (e).
- (g) After completion of the adjustment, set the three way valves (both high and low pressure sides) to the positions indicated by the arrow marks shown below.

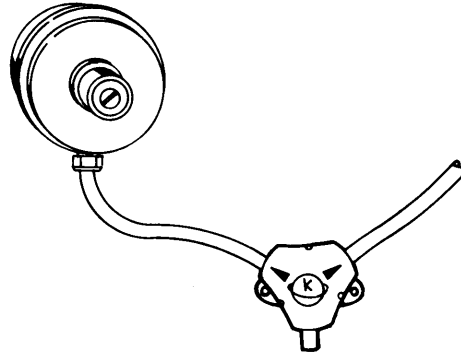

- (h) Remove the adjustor and connect the lead wires to the original terminals.

7.3 Dual pressure switch

- (1) Attach a pressure and a compound gauge.
(See 9. Maintenance – attaching pressure gauge)
- (2) High pressure side
 - (a) Raise high pressure by covering the air suction inlet or the air discharge outlet of the air cooled condenser with a blind plate. When high pressure cannot be raised because of low outdoor temperature, forcibly make the pressure switch for water function so as to stop the fan, or remove the wiring for fan motor and put the unit in the air cooled operation without fan operation.
 - (b) Read pressure indication when the unit is stopped. This is value of pressure at OFF.
 - (c) Leave the unit in the state of (b) and read pressure indication. This is value of pressure at ON.
 - (d) Provide the wiring again, which has been removed as in (a).
- (3) Low pressure side
 - (a) Accomplish the pump down with the stop valve at the water cooled condenser closed.
 - (b) Read pressure indication when the unit is stopped. This is value of pressure at OFF.
 - (c) Gradually open the stop valve at the outlet of the water cooled condenser to release the pump down and read pressure indication when the unit is restarted. This is value of pressure at ON.

Note: During the confirmation work stated in (c), if sudden pressure fluctuation occurs, the pressure switch may be delayed in function from the predesigned value. In this case reconfirm the values, accomplishing the work stated in from (a) to (c).
Further, the function on the low pressure side can be confirmed by the thermostat but for confirmation of precise setting, do it as stated in (a) – (c).

8 . Troubles and countermeasures

If the unit does not work properly, inspect it in accordance with “Troubles and countermeasures” to find cause of trouble and repair it.

Troubles and countermeasures

State	Phenomena	Functioning places	Cause	Countermeasures	
I. Cooling operation is inoperative	A: Condenser evaporator fans and compressor are inoperative.	a. No trouble with unit	<ul style="list-style-type: none"> ● Current interruption ● Power source is disconnected. 	<ul style="list-style-type: none"> ● Trace cause ● Connect power source plug to power source. 	
		b. Circuit breaker functions	<ul style="list-style-type: none"> ● It functions due to over current. 	<ul style="list-style-type: none"> ● Trace causes and replace. 	
		c. Fuse is burnt out.	–do–	–do–	
	B: Evaporator fans operative but condenser fans and compressor inoperative.	a. No trouble with unit	<ul style="list-style-type: none"> ● Thermostat functions and stops operation. ● Temperature setting is high. 	<ul style="list-style-type: none"> ● Readjust temp. setting as designed. 	
		b. Oil pressure control	<ul style="list-style-type: none"> ● It is not reset yet. 	<ul style="list-style-type: none"> ● Repair trouble and push down reset button. 	
		c. Solenoid valve does not function.	<ul style="list-style-type: none"> ● Coil is cut out. 	<ul style="list-style-type: none"> ● Replace it. 	
		d. Malfunction of recording temperature controller.	<ul style="list-style-type: none"> ● See article electronic recording temperature controller. 	<ul style="list-style-type: none"> ● Replace it. 	
	II. Cooling operation stops soon	A: Condenser fans and compressor stop, keeping evaporator fans in operation.	a. Oil pressure protection switch is functioning.	<ul style="list-style-type: none"> ● Oil pressure will not rise. ● Oil is short or oil pump is out of order. 	<ul style="list-style-type: none"> ● Additional oil charge, or repair oil pump.
			b. No trouble with unit	<ul style="list-style-type: none"> ● Thermostat functions and stops unit 	
		B: Condenser fans and compressor operate on and off repeatedly with evaporator fans in operation.	a. Pressure switch functions. ● High pressure side	● Excessive charge of refrigerant.	<ul style="list-style-type: none"> ● Discharge refrigerant.
				● Air in system	<ul style="list-style-type: none"> ● Air purge
				● Insufficient air flow for air cooled operation.	
● Condenser or passage clogged.				<ul style="list-style-type: none"> ● Clean or remove obstacles. 	
● Fan blade damaged.				<ul style="list-style-type: none"> ● Repair or replace. 	
● Fan motor does not rotate.					
Capacitor inoperative.				<ul style="list-style-type: none"> ● Replace it. 	
Fan motor thermostat has functioned.				<ul style="list-style-type: none"> ● Trace causes. 	
Insufficient water volume for cooling operation.					
● Condenser is clogged with scale.					
● Lower pressure side	Insufficient refrigerant charge	<ul style="list-style-type: none"> ● Additional charge, seek leaking positions and repair. 			
	Dryer clogging	<ul style="list-style-type: none"> ● Replace 			
	Moisture chokes.	<ul style="list-style-type: none"> ● Exchange dryer. 			
	Gas leakage from feeler tube of expansions valve.	<ul style="list-style-type: none"> ● Exchange it. 			
	b. Over-current relay or compressor protection thermostat has functioned.	<ul style="list-style-type: none"> ● Excessive large current due to over-load operation. 	<ul style="list-style-type: none"> ● Trace causes. 		

State	Phenomena	Functioning places	Cause	Countermeasures
III. Storage temp. is lower than temperature setting	A: Compressor inoperative.	a. Solenoid valve will not close.	Clogged with dust.	Replace it.
		b. Thermostat does not function.	See article electronic recording temperature controller	Replace it.
		c. Wrong installation of feeler tube.	Wrong installation of feeler tube.	Reattach it.
IV. Water cooled operation inoperative	A: Fans run continuously after water joints have been connected.	a. Water pressure switch does not function.	Insufficient cooling water volume (clogging or leakage of piping system).	Trace causes.
			Water leakage from water piping to switch.	Repair leaking point.
V. Heating	A: Heater is inoperative.	a. No trouble with unit	Temp. setting of thermostat is lower than -6.7°C (20°F) Heating is not required, as load is small.	
		b. Firestat	Insufficient evaporator air volume	
VI. Defrosting operation	A: Defrosting does not start.	a. Air switch does not function.	Bad connection, damage or clogging of connecting hose.	Repair or replace.
	B: Defrosting and refrigerating operation are repeated in a short period of time.	a. Air switch makes an error.	Improper adjustment	Readjustment

9 . Maintenance

It is important to study thoroughly how to maintain the equipment properly reading the following items before the unit is operated.

○ Pump down

What we call “pump down” is to collect the refrigerant in the refrigeration system in the condenser and its purpose is to prevent the refrigerant from leaking when the refrigerant system is repaired.

Accomplish pump down in the following order.

- (1) Attach pressure gauges both to the high and the low pressure sides of the compressor.
- (2) Operate the compressor. (Either water or air cooled)
- (3) Close the stop valve at the outlet of the water cooled condenser.
- (4) When a vacuum is created on the low pressure side, watching the low pressure gauge, stop the operation and close the stop valve at the outlet of the compressor. Repeat the procedure two or three times, and the refrigerant is collected in the water cooled condenser. In case the pressure gauge is not attached, the operation is stopped by the dual pressure switch on the low pressure side.

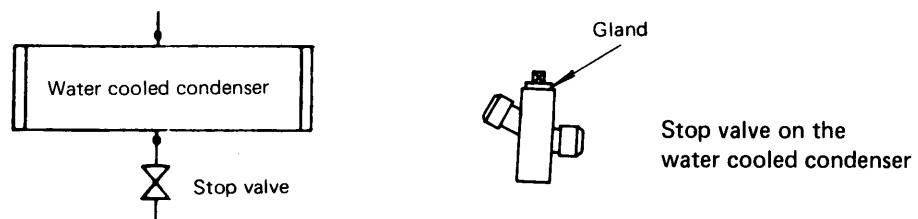

When the stop valve is closed, remove the cap, and then loosen the gland to a degree that the gas is not discharged, and then tighten the handle fully. Finally, tighten the gland.

When opening it, do the above in the reverse order.

○ Attaching pressure gauge

It is recommendable to attach the pressure gauge, because the operation state is easily confirmed and adjusted. Therefore, attach it as much as possible in the following manners. (When attaching it, the operation should be stopped).

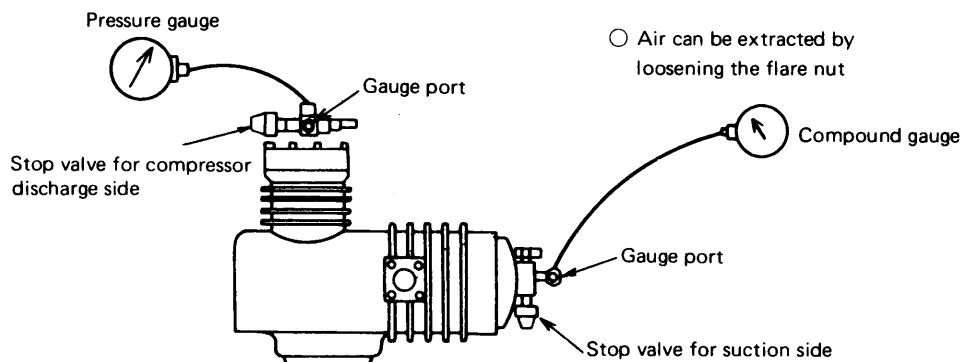

Piping connection for pressure gauge

- (1) Fully open the stop valves on the suction and discharge sides of the compressor and connect the gauge piping to the gauge port.
- (2) Set the handle of the stop valve at the neutral position. (The needle of the gauge rises up).
- (3) Vent the air through the gauge piping.

The following are the handle methods of the stop valves attached to the compressor.

- (1) Remove the cap.
- (2) Loosen the gland to a degree that no gas is discharged.
- (3) Fully tighten the handle, and the refrigerant passage forms between I and III.
- (4) Fully turn back the handle, and the refrigerant passage forms between II and III.
- (5) Set the handle at the neutral position, and the refrigerant passage forms among I–II–III.
- (6) As mentioned in 3, 4, 5, the refrigerant passage is formed differently, attach it properly to suit your respective conditions.
- (7) After having manipulated the handle, be certain that the gland is closed and capped.

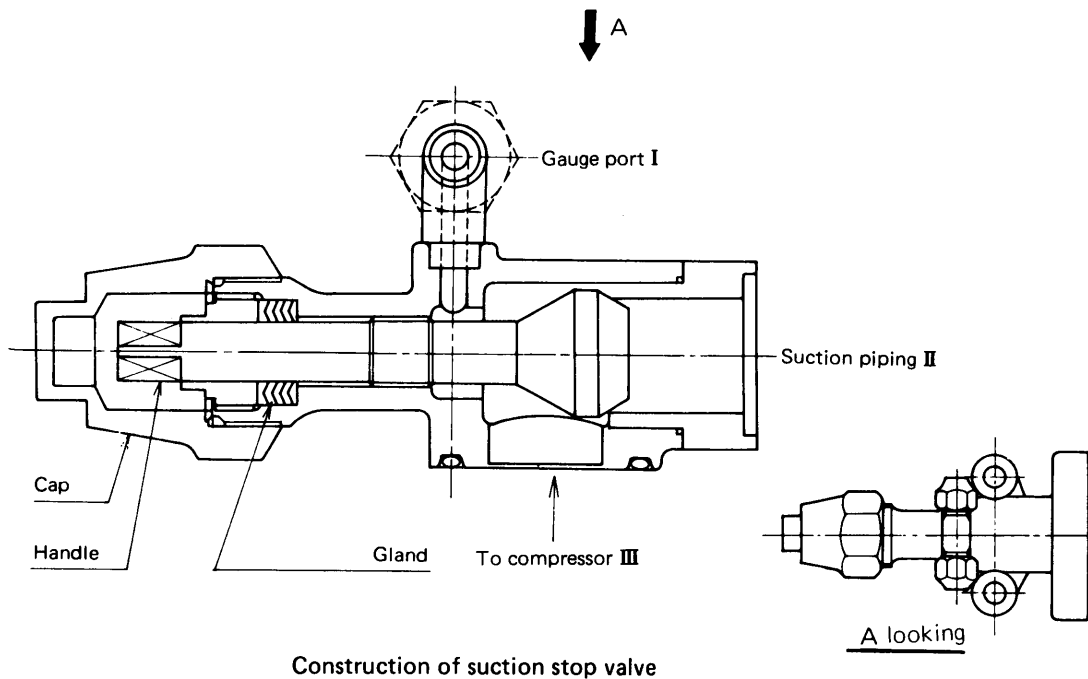

9.1 Replacement of fusible plug

When pressure rises abnormally in the system, the fusible plug melts itself, so if the fusible plug is melted, check possible causes thoroughly.

When fusible plug functions, the centre of the fusible plug alloy ② melts, from which the refrigerant jets out. When the flare nut is removed, ① is apt to come out by pressure and clogs the passage of the refrigerant outlet, which prevents the refrigerant from jetting out and also the air from entering. Thus, refrigerant loss is extremely minimized.

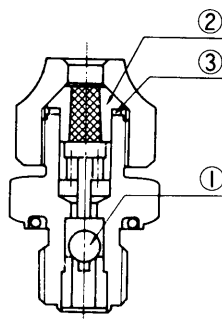

Construction of fusible plug

Insert a new ② by means of ③, and tighten the flare nut.

9.2 Replacement of dryer

In case water in the system cannot be removed or the dryer is clogged, replace the dryer with a new one.

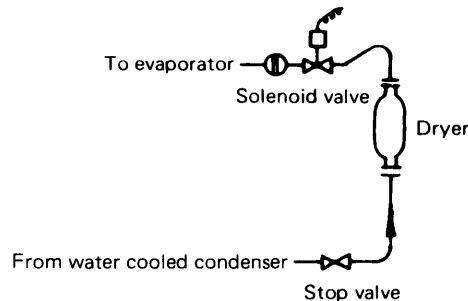

Piping diagram around the dryer

The dryer is located at the outlet side of the water cooled condenser (or the receiver), and can be replaced in the following way.

- (1) Attach the pressure gauge to the stop valve at the outlet of the water cooled condenser (or the receiver).
- (2) Close the stop valve at the outlet of the water cooled condenser (or the receiver) and accomplish pump down.
- (3) When the reading of the pressure gauge becomes approx. 1 kg/cm^2 , set it at OFF. At this moment, the solenoid valve is closed.
- (4) Close the stop valve on suction side of the compressor.
- (5) Remove the band for fixing the dryer.
- (6) Then, remove the flange bolts before and after the dryer and attach a new dryer. When the dryer is removed, be careful not to let the O rings at the upper and the lower flange parts fall off.
- (7) Vent the air which invaded in from the gauge port of the stop valve at the outlet of the water cooled condenser (or the receiver) while replacing the dryer with a new one.

9.3 Purging of non-condensable gas

If non-condensable gas such as air exists in the refrigeration circuit, it is collected in the condenser which rises pressure in the condenser abnormally high, and at the same time heat transferring ration of the condenser surface is reduced, resulted in lowering of refrigeration capacity. It is therefore very important to extract non-condensable gas.

In case discharge pressure is abnormally high and cannot be reduced to the normal (although cooling water volume is increased in case of water cooled operation), check if non-condensable gas exists in the following method.

*Stop the compressor, close the stop valve of the condenser or the liquid receiver and wait until entering and leaving condenser cooling water (or air) temperatures become equal. If there is any difference between condensing pressure and saturated pressure corresponding to cooling water (air) temperature, non-condensable gas must exist in the refrigeration circuit. Extract non-condensable gas as stated below.

- (1) Pump down
- (2) Condense the refrigerant as much as possible, and then purge non-condensable gas from the stop valve at the discharging side of the compressor.
- (3) Check the pressure gauge, and repeat the above stated procedure until condensing pressure is equal to saturated pressure.

9.4 Additional charge of refrigerant

● Charging the refrigerant

In case the refrigerant becomes short because of refrigerant leakage during the operation or refrigerant purge for repair, charge it additionally after thorough check of gas leaking points. However, the charging amount of the refrigerant has already been fixed, so do not use the following method except at the time of emergency.

[Work order]

Connect the refrigerant cylinder to gauge port of the stop valve at the suction side of the compressor temporarily, and open the stop valve of the cylinder a little to purge the air in the connecting pipe. Then, charge the refrigerant, keeping the compressor in operation.

At this time, keep the following items strictly.

- (1) Pressure in the cylinder should be higher than pressure on the low pressure side.
- (2) In case the refrigerant is charged, attach a dual pressure gauge, and pump down the refrigerant with the stop valve at the outlet of water cooled condenser closed, and charge the refrigerant until liquid level reaches to approximately half of the liquid level gauge.

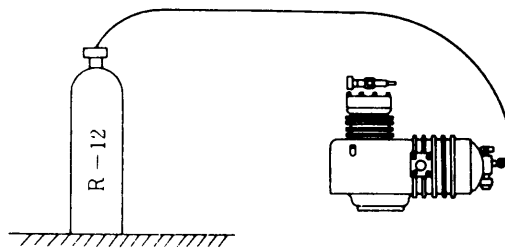

Piping connection for refrigerant charging

9.5 Vacuum drying and charging refrigerant and lubricant

In case the refrigerant becomes short and the air is intermixed, it is necessary to charge the predesigned amount of the refrigerant additionally after repairing and the vacuum drying. Further, when the lubricant is replenished, the same procedures as mentioned above are also required.

● In case the refrigerant alone is replaced

[Necessary parts]

- (1) Cylinder of R-12 (contains 20 kg)
- (2) $\phi 6.4$ copper tube (with 2 ea of flare nuts)
- (3) Scale (50 kg)
- (4) Machine tools
- (5) Vacuum pump

[Work order]

- (1) Connect the vacuum pump to the gauge fittings of the stop valve on the suction and delivery sides of the compressor and form vacuum of approx. 76 cmHg in the refrigerant system for about 4 hours and disconnect the vacuum pump, maintaining the vacuum in it.

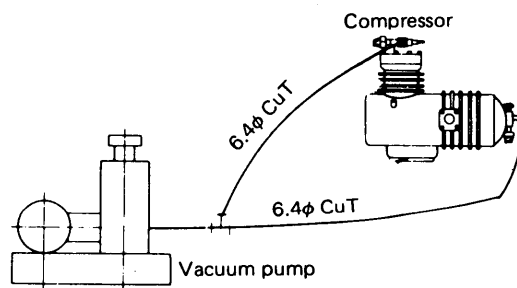

Piping connection for vacuum drying

- (2) Connect the cylinder to the stop valve on the suction side of the compressor and purge the air in the connecting pipe.
- (3) Place the cylinder on the scale and record its weight.

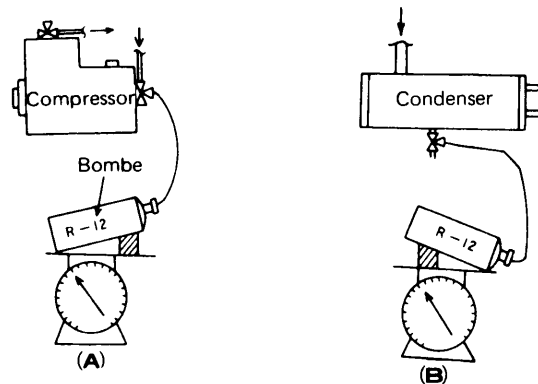

Weighing method of refrigerant

- (4) In case the refrigerant is charged in the gaseous state, do it as shown in (A) in the above figure. If the refrigerant becomes difficult to be charged, operate the compressor.
 - (5) In case the refrigerant is charged in the liquid state, do it as shown in (B) in the above figure. Accomplish pump down so as not to allow the liquid collected in the water cooled condenser to pass. If the refrigerant becomes difficult to be charged, operate the compressor.
 - (6) Charge the predesigned volume of the refrigerant as stated in (4) or (5).
 - (7) After completion of the refrigerant charge, adjust the stop valve to the original state and operate the compressor.
- **Both the refrigerant and the lubricant are replaced**
 - (1) Purge all the refrigerant gas so that refrigerant pressure becomes zero, and then drain all the lubricant by loosening the oil drain plug at the bottom of the compressor.
 - (2) Close the oil drain plug.
 - (3) Fill the compressor with the lubricant in the predesigned amount from the oil plug of the compressor.
 - (4) Charge the refrigerant.

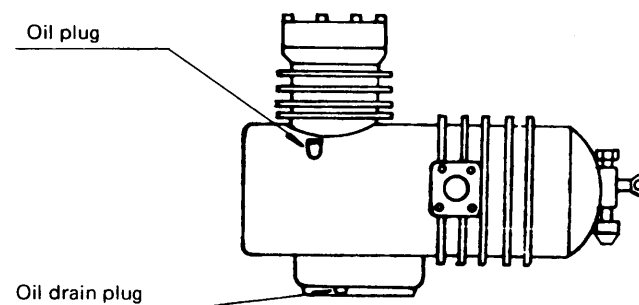

Oil charging

9.6 Gas leakage test

After all the procedures as mentioned before are completed, be sure to test the entire system for gas leakage with a halide torch gas detector carefully.

9.7 Caution for replacement of flexible tube

Although the flexible tubes used are carefully selected, if any of them is damaged, replace it with a new one.

Two flexible tubes are attached; i.e. one is attached to the suction line and the other to the discharge line. When they are replaced, carefully do as follows.

Caution for welding

When the flexible tube is connected to the pipe by welding, heat the inlet metal with flame of the torch as shown in the figure below and do not heat the welded part of the blade fixture by wrapping wet asbestos. If the welded part of the blade fixture is heated excessively, air tightness is damaged which may cause leakage.

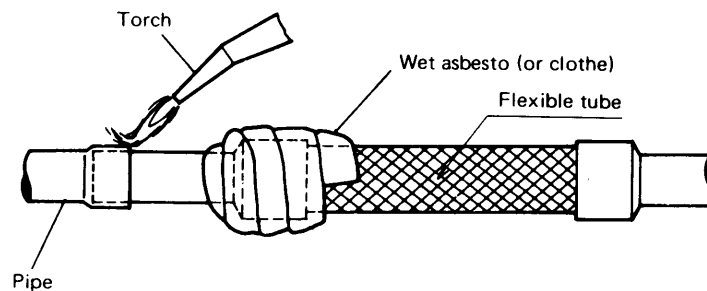

Flexible tube soldering

Caution for the work after flexible tube was connected

The flexible tube on the suction side should be thoroughly dried on its surface and provided with the thermal contractive tube around it to avoid water in the atmospheric air. In addition, the flexible tube on the discharge side should be wound precisely (more than duplex winding) with silicon tape. If there is any gap in the insulation, water freezes up on it, which may cause corrosion or damage.

9.8 Caution for replacement of compressor

Vibration protective rubbers are attached to the bottom of the compressor. In addition stoppers are provided to protect the compressor from abnormal movement caused by impact. The stoppers attached are available in three kinds, (A) (B) and (C) and totally four stoppers are attached. When the stoppers (A) are attached (two points at front and rear), take a gap smaller than 3 mm (shown with * in the figure) between the compressor and the stopper (A).

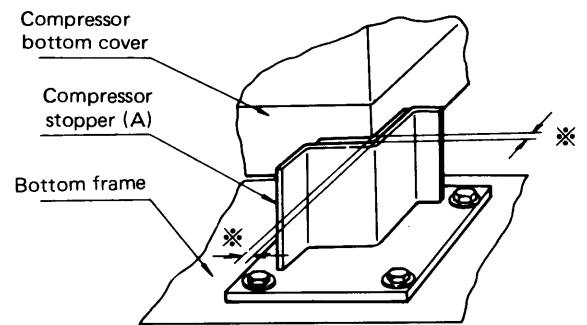
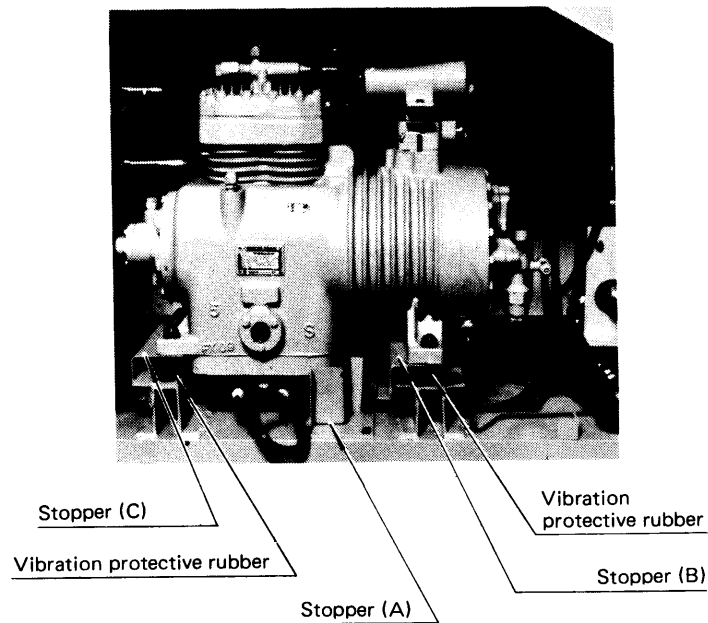

<https://daikin-p.ru>

When power cable are put back,
be sure to the plug to be downward.

<https://daikin-p.ru>

DAIKIN INDUSTRIES LTD



Tokyo Branch Shinjuku Sumitomo Bldg 6, 2-chome Nishi-Shinjuku Shinjuku-ku Tokyo Japan

Post No. 160-91 Tel. (03) 347-8257

Telex . 32540

Cable ADDRESS: TKYDAIKINOKAY